

Instruction Manual



1730-Series Waveform Monitor (SN B070000 and Above) 070-7948-05

Warning

The servicing instructions are for use by qualified personnel only. To avoid personal injury, do not perform any servicing unless you are qualified to do so. Refer to all safety summaries prior to performing service.



Copyright © Tektronix, Inc. All rights reserved.

Tektronix products are covered by U.S. and foreign patents, issued and pending. Information in this publication supercedes that in all previously published material. Specifications and price change privileges reserved.

Printed in the U.S.A.

Tektronix, Inc., P.O. Box 1000, Wilsonville, OR 97070-1000

TEKTRONIX and TEK are registered trademarks of Tektronix, Inc.

WARRANTY

Tektronix warrants that this product, that it manufactures and sells, will be free from defects in materials and workmanship for a period of three (3) years from the date of shipment. If any such product proves defective during this warranty period, Tektronix, at its option, either will repair the defective product without charge for parts and labor, or will provide a replacement in exchange for the defective product.

In order to obtain service under this warranty, Customer must notify Tektronix of the defect before the expiration of the warranty period and make suitable arrangements for the performance of service. Customer shall be responsible for packaging and shipping the defective product to the service center designated by Tektronix, with shipping charges prepaid. Tektronix shall pay for the return of the product to Customer if the shipment is to a location within the country in which the Tektronix service center is located. Customer shall be responsible for paying all shipping charges, duties, taxes, and any other charges for products returned to any other locations.

This warranty shall not apply to any defect, failure or damage caused by improper use or improper or inadequate maintenance and care. Tektronix shall not be obligated to furnish service under this warranty a) to repair damage resulting from attempts by personnel other than Tektronix representatives to install, repair or service the product; b) to repair damage resulting from improper use or connection to incompatible equipment; c) to repair any damage or malfunction caused by the use of non-Tektronix supplies; or d) to service a product that has been modified or integrated with other products when the effect of such modification or integration increases the time or difficulty of servicing the product.

THIS WARRANTY IS GIVEN BY TEKTRONIX WITH RESPECT TO THIS PRODUCT IN LIEU OF ANY OTHER WARRANTIES, EXPRESSED OR IMPLIED. TEKTRONIX AND ITS VENDORS DISCLAIM ANY IMPLIED WARRANTIES OF MERCHANTABILITY OR FITNESS FOR A PARTICULAR PURPOSE. TEKTRONIX' RESPONSIBILITY TO REPAIR OR REPLACE DEFECTIVE PRODUCTS IS THE SOLE AND EXCLUSIVE REMEDY PROVIDED TO THE CUSTOMER FOR BREACH OF THIS WARRANTY. TEKTRONIX AND ITS VENDORS WILL NOT BE LIABLE FOR ANY INDIRECT, SPECIAL, INCIDENTAL, OR CONSEQUENTIAL DAMAGES IRRESPECTIVE OF WHETHER TEKTRONIX OR THE VENDOR HAS ADVANCE NOTICE OF THE POSSIBILITY OF SUCH DAMAGES.

Table of Contents

Table Of Contents	i
Operators Safety Summary	ix
Preface	xi
Section 1 Introduction and Specification	1-1
Typical Configurations	1-2
Options	1-3
CRT Options	1-3
Power Cord Options	1-3
Accessories	1-3
Standard Accessories	1-3
Optional Accessories	1-3
Safety Information	1-4
Specification	1-4
Section 2 Operating Instructions	2-1
Front-Panel Controls and Indicators	2-1
Horizontal	2-3
Display	2-4
Power	2-5
Line Select	2-5
Recall Setup	2-6
Miscellaneous	2-7
Rear-panel Connectors	2-7
Bnc Connectors	2-7
Multi-Pin Connectors	2-8
Power Input	2-9
Operator's Checkout Procedure	2-9
Procedure	2-10
Graticules	2-21
NTSC Composite Video Graticule Vertical Scales	2-21
Horizontal Scales for NTSC and PAL Graticules	2-23
PAL Graticule Vertical Scales	2-23
Dual Graticule Vertical Scales	2-25
Preset Front-Panel Measurements	2-26
RGB/YRGB Display	2-27
Remote Sync	2-27
90 Hz (NTSC) or 100 Hz (PAL) Trigger	2-27
Servicing Safety Summary	S-1
Section 3 Installation	3-1
Packaging	3-1
Electrical Installation	3-1
Power Source	3-1
Mains Frequency and Voltage Ranges	3-1

Operating Options	3-1
REMOTE Connector	3-3
90 Hz (100 Hz) D-2 Trigger	3-5
RGB/YRGB Parade Display	3-6
Procedure for setting RGB Offset	3-7
AUXILIARY Connector	3-7
Mechanical Installation	3-8
Cabinets	3-8
Cabinetizing	3-10
Rack Adapter	3-10
Custom Installation	3-12
Section 4 Theory of Operation	4-1
Overview	4-1
Block Diagram	4-2
Circuit Blocks	4-2
CRT, Unblanking, and High Voltage	4-4
Vertical Input	
Diagram 1	4-4
Input Amplifiers	4-5
Channel Switch	4-5
External Sync Input and Source Switch	4-6
Sync Stripper	4-6
Filter Selection	4-7
Calibrator	4-8
Vertical Output	
Diagram 2	4-8
Gain Cell	4-8
Gain Cell Amplifier	4-9
2nd DC Restorer	4-9
Switchable Gain Amplifier	4-9
Vertical Output Amplifier	4-10
Pix Monitor	4-11
Timing	
Diagram 3	4-11
Horizontal Sync Generator	4-12
Vertical Sync Generator	4-13
RGB Amplifier	4-13
Field ID and Trigger Select	4-13
Sweep Generators and Horiz Output	
Diagram 4	4-16
Sweep Generator	4-16
Magnifier Amplifier	4-17
Horizontal Output Amplifier	4-18
Microcontroller	
Diagram 5	4-18
Microprocessor	4-18
NOVRAM	4-20
Switch Control	4-21
Address Demux	4-21
Readout Drive	4-21
I/O Data Latch	4-21
Cal Drive	4-21

LED Drive	4-21
Control Circuit	
Diagram 6	4-22
Focus Control	4-22
Z-Axis Control	4-22
Trace Rotation	4-23
Graticule Illumination	4-23
± 11.8 V Regulators	4-23
Front Panel Diagram 7	4-24
Indicators and Switches	4-24
Controls	4-24
Low Voltage Power Supply Diagram 8	4-25
Line Rectifier and Filter	4-25
Pulse Width Modulator	4-26
Output Filters	4-27
Error Amplifier	4-27
Feedback Transformer Driver and Peak Detector	4-27
Output Under-Voltage Shutdown	4-27
High Voltage Power Supply Diagram 9	4-27
HV Osc and Error Amp	4-28
Power Supply Outputs	4-28
Focus Amplifier	4-28
Grid Drive Circuit	4-28
Z-Axis Amplifier	4-29
Section 5 Checks and Adjustments	5-1
Recommended Equipment List	5-1
Electrical Instruments	5-1
Auxiliary Equipment	5-3
Performance Check	5-7
Short-form Procedure	5-7
Performance Check Procedure	5-10
Adjustment Procedure	5-27
Short-form Procedure	5-27
Standard Adjustment Procedure	5-28
Section 6 Maintenance	6-1
Preventive Maintenance	6-1
Cleaning	6-1
Visual Inspection	6-2
Static-Sensitive Components	6-2
Performance Checks and Readjustments	6-3
Troubleshooting	6-3
Foldout Pages	6-4
Parts Lists	6-5
Major Assembly Interconnection	6-6
General Troubleshooting Techniques	6-7
Specific Troubleshooting Techniques	6-8
Power Supply	6-8
Troubleshooting Procedure	6-8
Introduction	6-9
Low Volts Supply	6-9

High Volts Supply	6-12
Serial Port and LED Driver Diagnostics	6-14
Corrective Maintenance	6-15
Obtaining Replacement Parts	6-15
Mechanical Disassembly/Assembly	6-16
Bezel Removal	6-16
Graticule Light Removal and Replacement	6-17
Removing the Rear Panel	6-19
Removing the Front Panel and the Front Panel Circuit Board	6-19
Removing the Main Board	6-21
Removing the Power Supply Board	6-22
Repackaging	6-23
Identification Tag	6-23
Repackaging for Shipment	6-23
Section 7 Options	7-1
CRT Options	7-1
Power Cord Options	7-1
Cabinets	7-1
Plain Cabinet (1700F00)	7-1
Carrying Case (1700F02)	7-2
Side-by-Side Rack Adapter (1700F05)	7-2
Blank Panel (1700F06)	7-2
Utility Drawer (1700F07)	7-2
Ordering	7-3
Section 8 Replaceable Electrical Parts	8-1
Parts Ordering Information	8-1
Using the Replaceable Electrical Parts List	8-1
Column Descriptions	8-2
Cross Index – Mfr. Code Number To Manufacturer	8-3
Replaceable Electrical Parts	8-6
Section 9 Diagrams/Circuit Board Illustrations	9-1
Section 10 Replaceable Mechanical Parts	10-1
Parts Ordering Information	10-1
Using the Replaceable Mechanical Parts List	10-1
Cross Index–Mfr. Code Number to Manufacturer	10-1
Abbreviations	10-1
Chassis Parts	10-1
Column Descriptions	10-2
Figure & Index No. (Column 1)	10-2
Tektronix Part No. (Column 2)	10-2
Serial No. (Column 3 and 4)	10-2
Qty (Column 5)	10-2
Name and Description (Column 6)	10-2
Mfr. Code (Column 7)	10-2
Mfr. Part Number (Column 8)	10-2
Cross Index – Mfr. Code Number To Manufacturer	10-3
Replaceable Mechanical Parts	10-4

List of Figures

Figure 2-1: 1730-Series front-panel control locations.	2-2
Figure 2-2: 1730-Series rear panel.	2-8
Figure 2-3: Equipment connections for the 1730-Series “Operator’s Checkout Procedure.”	2-10
Figure 2-4: Two-line color bar display in FLAT filter mode.	2-12
Figure 2-5: Checking vertical gain calibration with the 1730-Series internal calibrator (CAL) reference.	2-13
Figure 2-6: Dual channel, 2-line display of color bar and linearity signals.	2-14
Figure 2-7: Checking timing with the internal calibrator signal.	2-15
Figure 2-8: Two-line display of color bar signal with LOW PASS filter on.	2-16
Figure 2-9: Two-line display of color bar signal with CHROMA filter.	2-17
Figure 2-10: Two-line display with dual filter selected.	2-17
Figure 2-11: Two-line display with LINE SELECT on.	2-18
Figure 2-12: Two-field display with intensified line in the first displayed field.	2-19
Figure 2-13: Two-field display with 15 line mode of the LINE SELECT on.	2-19
Figure 2-14: A 1-line sweep rate with 15 continuous lines (from mid field) displayed using LINE SELECT.	2-20
Figure 2-15: Display of vertical interval with magnified 2 field sweep.	2-20
Figure 2-16: NTSC graticule.	2-22
Figure 2-17: PAL graticule.	2-24
Figure 2-18: Dual standard graticule.	2-26
Figure 3-1: Plug jumper locations and RGB compensation adjustments.	3-2
Figure 3-2: REMOTE connector pin functions.	3-4
Figure 3-3: Common parts used to convert from +28 VDC enable to ground closure.	3-6
Figure 3-4: AUXILIARY connector pin functions.	3-7
Figure 3-5: Dimensions of the 1700F00 plain cabinet.	3-8
Figure 3-6: 1700F02 portable cabinet.	3-9
Figure 3-7: Rear view of the instrument, shown in the cabinet, with the securing screws identified.	3-10
Figure 3-8: The 1700F05 side-by-side rack adapter.	3-11
Figure 3-9: A 1700-Series instrument mounted in a 1700F05 cabinet with a blank front panel (1700F06) covering the unused side of the cabinet.	3-11
Figure 3-10: A 1700F05 side-by-side rack mounting cabinet with an instrument and a 1700F07 utility drawer.	3-12

Figure 3-11: Considerations for custom installation of an instrument.	3-13
Figure 4-1: Simplified representation of the 1730-Series Waveform Monitor. . .	4-1
Figure 4-2: Simplified block diagram of the Sync Stripper.	4-7
Figure 4-3: Simplified illustration of the Bridge limiter circuit.	4-10
Figure 4-4: Simplified representation of the AFC phase-lock loop.	4-12
Figure 4-5: Elements for line select timing.	
Figure 4-6: Relative line select elements for the 2-line display.	4-15
Figure 4-7: Relative line select timing elements for the 1-line display.	4-16
Figure 4-8: Timing signals for 1-line and 2-line sweep.	4-17
Figure 4-9: Z-axis timing for readout.	4-23
Figure 4-10: Pinout of the CRT Socket	4-30
Figure 5-1: Remote connector for RGB.	5-5
Figure 5-2: Remote connector for 90/100 triggering.	5-6
Figure 5-3: Ten full cycles of calibrator signal between timing marks.	5-13
Figure 5-4: Equipment hook-up for checking vertical gain.	5-16
Figure 5-5: Checking PIX MON OUT signal amplitude.	5-18
Figure 5-6: Initial equipment setup to check flat response.	5-20
Figure 5-7: Adjustment locations for the Main and Power Supply boards.	5-29
Figure 5-8: Segment of the Main board, showing the test points and adjustment locations for the +11.8 V supplies.	5-31
Figure 5-9: Equipment setup to adjust 0.2 ms timing.	5-32
Figure 5-10: Equipment setup for adjusting the calibrator amplitude.	5-35
Figure 5-11: Equipment setup for adjusting Channel A input compensation. . .	5-36
Figure 5-12: Adjusting for best flat response.	5-37
Figure 5-13: Using the high-range multiburst signal to set flatness.	5-39
Figure 6-1: Circuit board assembly locations.	6-5
Figure 6-2: Multiple pin connectors used in the 1730-Series Waveform Monitor	6-6
Figure 6-3: Bezel removal.	6-17
Figure 6-4: Rear panel securing screws.	6-19
Figure 6-5: Screws that hold the Front Panel circuit board (A2) in place.	6-21
Figure 6-6: Screws holding the Main circuit board (A3) in place.	6-22
Figure 6-7: Screws holding the Power Supply circuit board (A1) in place.	6-23
Figure 6-8: Repackaging a 1730-Series instrument.	6-24

List of Tables

Table 1–1: Vertical Deflection System	1–5
Table 1–2: DC Restoration	1–7
Table 1–3: Calibrator	1–7
Table 1–4: Horizontal Deflection System	1–7
Table 1–5: Synchronization	1–9
Table 1–6: RGB/YRGB Mode	1–10
Table 1–7: CRT Display	1–11
Table 1–8: Power Source	1–11
Table 1–9: Environmental Characteristics	1–11
Table 1–10: Certifications and compliances	1–12
Table 1–11: Physical Characteristics	1–13
Table 2–1: Preset Front Panels	2–26
Table 3–1: Internal Jumper Selections	3–2
Table 3–2: Remote Connector Pin Assignments and Functions	3–4
Table 3–3: Auxiliary Control Pin Assignments	3–8
Table 4–1: Control Line Functions	4–19
Table 6–1: Static Susceptibility	6–2
Table 6–2: Power Supply Fault Symptoms	6–9
Table 6–3: Low Volts Supply Voltages	6–9
Table 6–4: Control Circuit Test Points	6–11
Table 6–5: High Volts Supply Fault Symptoms	6–12
Table 6–6: High Voltage Oscillator Test Points	6–13

General Safety Summary

Review the following safety precautions to avoid injury and prevent damage to this product or any products connected to it. To avoid potential hazards, use this product only as specified.

Only qualified personnel should perform service procedures.

To Avoid Fire or Personal Injury

Use Proper Power Cord. Use only the power cord specified for this product and certified for the country of use.

Connect and Disconnect Properly. Do not connect or disconnect probes or test leads while they are connected to a voltage source.

Ground the Product. This product is grounded through the grounding conductor of the power cord. To avoid electric shock, the grounding conductor must be connected to earth ground. Before making connections to the input or output terminals of the product, ensure that the product is properly grounded.

Observe All Terminal Ratings. To avoid fire or shock hazard, observe all ratings and markings on the product. Consult the product manual for further ratings information before making connections to the product.

Do not apply a potential to any terminal, including the common terminal, that exceeds the maximum rating of that terminal.

Do Not Operate Without Covers. Do not operate this product with covers or panels removed.

Use Proper Fuse. Use only the fuse type and rating specified for this product.

Avoid Exposed Circuitry. Do not touch exposed connections and components when power is present.

Do Not Operate With Suspected Failures. If you suspect there is damage to this product, have it inspected by qualified service personnel.

Do Not Operate in Wet/Damp Conditions.

Do Not Operate in an Explosive Atmosphere.

Keep Product Surfaces Clean and Dry.

Provide Proper Ventilation. Refer to the manual's installation instructions for details on installing the product so it has proper ventilation.

Symbols and Terms

Terms in this Manual. These terms may appear in this manual:



WARNING. *Warning statements identify conditions or practices that could result in injury or loss of life.*



CAUTION. *Caution statements identify conditions or practices that could result in damage to this product or other property.*

Terms on the Product. These terms may appear on the product:

DANGER indicates an injury hazard immediately accessible as you read the marking.

WARNING indicates an injury hazard not immediately accessible as you read the marking.

CAUTION indicates a hazard to property including the product.

Symbols on the Product. The following symbols may appear on the product:

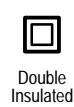

Preface

This manual documents the TEKTRONIX 1730–Series Waveform Monitor (B070000 and Up). Information that applies to all instruments in the series refers to the 1730–Series. Information that applies to only specific instruments within the series refers to the model numbers of those instruments (i.e., 1730, 1731, etc.).

The information in this manual is intended for instrument operators and service technicians. Operators are assumed to be familiar with basic television terms and measurements. Qualified service technicians are also assumed to be familiar with television terms and measurements, and have moderate experience with analog and logic circuits.

Section 1, Introduction, includes a general description of the instrument followed by the Specifications. The Specifications include references to the corresponding Performance check steps.

Section 2, Operating Instructions, familiarizes the user with the front– and rear– panel controls, connectors, and indicators; includes an operator’s checkout procedure; and includes other operator familiarization information.

Section 3, Installation, includes electrical and mechanical installation information. The electrical installation information includes power mains conversion, adjustments, and operational changes available with the instrument. The mechanical installation information includes rackmounting, custom installation, and portable use.

Section 4, Theory of Operation, provides an overall block diagram description and detailed circuit descriptions. Read the block diagram description for an overview of the instrument. The detailed circuit descriptions should be used with the block diagram and schematic diagrams in the foldout pages for specific information about individual circuits.

Section 5, Checks and Adjustments, includes the Performance Check Procedure and the Adjustment Procedure. The Performance Check Procedure is used to verify that the instrument’s performance is within its specifications, and the Adjustment Procedure is used to adjust the instrument to meet its specifications. The procedures are preceded by a list of recommended test equipment. Each procedure has a short form listing of the individual steps.

Section 6, Maintenance, includes preventive, troubleshooting, and corrective information.

Section 7, Options, contains summaries of available instrument options. Additional information concerning options is included in appropriate places throughout the manual.

Section 8, Replaceable Electrical Parts, includes ordering information and part numbers for all replaceable electrical parts.

Contacting Tektronix

Product Support	<p>For application-oriented questions about a Tektronix measurement product, call toll free in North America: 1-800-TEK-WIDE (1-800-835-9433 ext. 2400) 6:00 a.m. – 5:00 p.m. Pacific time</p> <p>Or contact us by e-mail: tm_app_supp@tek.com</p> <p>For product support outside of North America, contact your local Tektronix distributor or sales office.</p>
Service Support	<p>Contact your local Tektronix distributor or sales office. Or visit our web site for a listing of worldwide service locations.</p> <p>www.tektronix.com</p>
For other information	<p>In North America: 1-800-TEK-WIDE (1-800-835-9433) An operator will direct your call.</p>
To write us	<p>Tektronix, Inc. P.O. Box 1000 Wilsonville, OR 97070-1000</p>



Introduction and Specifications

Section 1

Introduction and Specification

The TEKTRONIX 1730-Series is an 8-1/2-inch wide by 5-1/4-inch high waveform monitor, weighing approximately 8 pounds. The 1730 (System M, NTSC) and the 1731 (System I, B, etc., PAL, PAL-M), and the 1735 (dual-standard) versions can be powered from an ac source or, with the addition of a field upgrade kit (1700F10), 12 Vdc. The CRT occupies approximately two-thirds of the front-panel area, with the control panel taking up the remainder of the space. Operation is controlled by a microprocessor that polls the front-panel switches and remote ground closures. Front-panel switches are of the momentary touch type with lighted functional indicators. Most of the switches are also used to select special functions, which are accessed by holding the switches in until the microprocessor recognizes the request.

The signal is displayed on a bright CRT capable of displaying one line per frame. It is of the mesh type, for better geometry, and uses an internal graticule to reduce parallax. Variable graticule scale illumination provides even lighting to improve measurement accuracy and the quality of waveform pictures. Option 74 provides a P4 (white) phosphor tube.

The Channel A and B Composite Video Inputs and the External Reference Signal Input are high impedance bridging loop-throughs, in order to protect the integrity of the signal paths. The input switching allows for the display of either Channel A or Channel B Input or both inputs. Synchronization can be either internal or external, with the further choices of using remote sync or 90 or 100 Hz synchronization, from a VTR, where the application warrants.

The 1730-Series offers a choice of three basic sweep rates: 2 Field, 2 Line, and 1 Line, each of which can be magnified to provide three additional sweep rates: $1\ \mu\text{s}$ (2 Line), $0.2\ \mu\text{s}$ (1 Line), and X25 (2 Field) which provides for viewing the complete vertical interval. In addition, there is full frame line selection that can be displayed as 1 line, 2 lines, or 15 lines. A bright-up pulse, for picture monitors, that corresponds to the intensified region on the CRT display, is available through a rear-panel bnc connector.

The vertical signal processing provides a choice of fast or slow dc restoration, or an unclamped display. The input signal can be unfiltered (Flat) or either Low Pass or Chrominance filtered. There is also a combination of Flat and Low Pass filtering available when a 2 Line or 2 Field sweep rate is employed; the display consists of one line or field low pass filtered while the second is unfiltered. Vertical amplitudes can be displayed in a calibrated gain mode, which corresponds directly with the graticule vertical scales, magnified 5 times, or can be set to a specific amplitude by using the Variable GAIN control.

An RGB or YRGB Parade display, for camera setup, is accommodated with a shortened sweep. The input of the camera signal and an enable are through the rear-panel REMOTE jack. The choice of 3-step (RGB) or 4-step (YRGB) is made by changing the position of an internal jumper.

The 1730-Series has a unique Store and Recall function built in that allows for the storing of up to four front-panel setups that can be recalled by pressing the appropriate recall button, or a ground closure through the rear-panel REMOTE connector. In addition, four factory-programmed measurement setups can be accessed, by external ground closures input through the REMOTE connector.

An auxiliary output, to control a companion 1720-Series Vectorscope, is provided through a rear-panel connector. The auxiliary output contains a bus for two-way communications between the waveform monitor and vectorscope microprocessors and a strobe to provide line select unblanking for the Vectorscope.

Typical Configurations

The 1730-Series Waveform Monitor is designed for operation either alone or with a 1720-Series Vectorscope. Line select and measurement recall for this waveform monitor are also used by the vectorscope. Because of these capabilities, and the available 90 or 100 Hz triggering, the 1730-Series Waveform Monitor is ideally suited to operate in a VCR bridge. With its factory-preset measurement routines, that can be accessed through the rear-panel REMOTE connector and the Store/Recall functions, it is possible to have one-button measurements of key parameters, including various vectorscope measurements.

In addition to the VCR bridge and the typical Master Control monitoring applications, this monitor can be used in camera chains. It has a choice of RGB or YRGB Parade display that can easily be selected by changing one internal jumper setting. The Parade signal and enable are input through the rear-panel REMOTE connector.

A number of operating conditions can be altered by changing internal jumpers, using some of the factory-preset combinations, or setting up and saving the front panel with the Store/Recall function. Using these methods most of the current 528A operational modes can be accommodated. There is a difference in how the remote control operates — the 1730-Series uses ground closures, not positive voltage as the 528A did.

Options

- CRT Options** The standard instrument is shipped with a P31 (green) phosphor CRT installed. Option 74 instruments are shipped with a P4 (white) phosphor CRT installed.
- Power Cord Options** Any of the power cord options described in Section 7 can be ordered for the 1730-Series. If no power cord option is ordered, instruments are shipped with a North American 125 V power cord and one replacement fuse.

Accessories

- Standard Accessories** The following accessories are shipped with the 1730-Series. Part numbers for these accessories are located at the end of the Replaceable Mechanical Parts list.
- 1 1730-Series Instruction Manual
 - 1 Power Cord, with selected power plug option
 - 1 Replacement Cartridge Fuse (correct rating for the power plug option)
 - 3 Replacement Scale Illumination Bulbs (Tektronix Part No. 150-0168-00 or ANSI #73)
- Optional Accessories** There are a number of accessories that can be used with a 1730-Series Waveform Monitor. The following is a list of the most common accessory items for this series of waveform monitors. 1700F items are Field Upgrade Kits that are installed by the customer; instructions are included in all Field Upgrade Kits.
- Viewing Hood (016-0475-00)
 - Front Panel Cover (200-3897-01)
 - 1700F00, Plain Cabinet (painted silver-grey)
 - 1700F02, Portable Cabinet (painted silver-grey)
 - 1700F05, Side-by-Side Rack Adapter
 - 1700F06, Blank Half-Rack Width Panel
 - 1700F10, DC Power Converter

Safety Information

The 1730-Series is intended to operate from an ac power source that will not apply more than 250 V rms between the supply conductors or between either supply conductor and ground. A protective ground connection by way of the grounding conductor is essential for safe operation (except for those instruments that are operated from a battery supply).

The 1730-Series was tested for compliance in a cabinet. To ensure continued compliance, the instrument will need to be enclosed in a cabinet that is equivalent to the Factory Upgrade Kits that are listed as Optional Accessories for the 1730-Series. A drawing of the 1700F00 plain cabinet is contained in the Installation Instructions (Section 3).

Specification

In the specification tables that follow, some items are identified as performance requirements. These can be verified by performing the Performance Check Procedure in Section 5. Not all performance requirements have a measurable tolerance, and therefore do not have a performance check step; however, they are either verified by indirect means, through other portions of the procedure, or are design criteria that do not need to be tested for individual instruments.

Whenever there is a verifiable performance requirement, in the specification table, there will also be a reference to identify the location, in the Performance Check Procedure, of the appropriate performance verification procedure.

The supplemental Information designation in the tables indicates that this is information that either amplifies a performance requirement or is special information that is of importance. Unlike performance requirements, there is no need, and often no way to check these items to any specific tolerance.

Table 1-1: Vertical Deflection System

Characteristic	Requirement	Supplemental Information	Step Number
Frequency response Flat	Flat: 50 kHz to 6 MHz within 2% of response at 50 kHz. Flat (X5): 50 kHz to 6 MHz within 5% of response at 50 kHz.	Specifications apply for full screen height video input signal, with variable GAIN off.	13
Low-pass filter	1730: At least 30 dB attenuation at 3.58 MHz 1735: 4.00 MHz 1731: 4.43 MHz	Response at 15 kHz does not vary between FLAT and LPASS by more than 1%	17
Chroma filter	NTSC and PAL-M: Nominal bandwidth 1 MHz. Attenuation at 7.2 MHz 20 dB or greater. Response at 3.58 MHz does not vary between FLAT and CHROMA by more than 1%.	Upper and lower -3 dB points are approximately ± 350 kHz from 3.579545 MHz. 15 to 35 °C operating temperature.	18
	PAL: Nominal bandwidth 1 MHz. Attenuation at 8.9 MHz 20 dB or greater. Response at 4.43 MHz does not vary between FLAT and CHROMA by more than 1%.	Upper and lower -3 dB points are approximately ± 350 kHz from 4.433619 MHz. 15 to 35 °C operating temperature.	
Transient response	Preshoot: $\leq 1\%$ Pulse-to-Bar Ratio: X1: 0.99:1 to 1.01:1 X5: 0.98:1 to 1.02:1 Overshoot: X1: 2% or less X5: 4% or less Ringing: X1: 2% or less X5: 4% or less	Specifications apply for full screen height video input signal, with variable GAIN off.	15, 16
Field rate tilt	$\leq 1\%$	Field rate square wave or vertical window	15
Line rate tilt	$\leq 1\%$	25 ms bar	15
Overscan	Less than 2% variation in baseline of 100 IRE (700 mV) 12.5T (20T) modulated pulse as it is positioned over the middle 80% of the screen.		15
Differential gain	Displayed differential gain is $\leq 1\%$ with 10% to 90% APL changes.	Chroma filter must be selected. Baseline at 50 IRE and displayed subcarrier adjusted to 100 IRE with VAR gain.	
Deflection factor	140 IRE (1.0 V) within 1% with 1 V input.	1 V full scale. 20-30 °C, Flat response selected. Vertical gain temperature coefficient is $-0.3\%/10$ °C.	9

Table 1-1: Vertical Deflection System (Cont.)

Characteristic	Requirement	Supplemental Information	Step Number
X5 gain accuracy	±5%	1 V input signal	9
X5 gain registration	≤1 major div. of vertical shift from baseline.	Unmagnified to magnified display	9
Variable gain range	Input signals between 0.8 V and 2 V can be adjusted to 140 IRE (1.0 V) display. 160 mV and 400 mV for X5 gain.		9
Position range	1 V signal can be positioned so that peak white and sync tip can be placed at blanking level, with the DC RESTORER on, regardless of gain setting.	Applies to calibrated gain positions only	9
Maximum absolute input level	±5 VDC + peak AC	Displays in excess of 200 IRE (1.428 V) may cause frequency response aberrations.	
DC input impedance	Greater than 15 kΩ (unterminated)		
Return Loss (75 Ω) video inputs (CH-A, CH-B)	≥40 dB from 50 kHz to 6 MHz	A and B channels, loop-through terminated in 75Ω. Input in use or not in use, instrument power on or off, all deflection factor settings.	19
Crosstalk between channels		Greater than 50 dB of isolation between channels. Measured at F _{SC} between Channel A, Channel B, and EXT REF.	
Loop through isolation		Greater than 80 dB of isolation between loop-throughs. Measured at F _{SC} between Channel A, Channel B, and EXT REF.	
PIX MON frequency response	50 kHz to 6 MHz, within 3% of response at 50 kHz	Terminated in 75 Ω	14
PIX MON differential gain (50% APL)	Within 1% with a 140 IRE (1.0 V) unit display		
PIX MON differential phase (50% APL)	Within 1° with a 140 IRE (1.0 V) unit display		
PIX MON DC level on output	0.5 V or less into 75 Ω. load	No input signal	11
PIX MON intensification (bright-up)		During line select only. Active video of selected lines has a DC offset of approximately 180 mV.	
PIX MON output impedance		75 Ω. (nominal)	
PIX MON return loss (75 Ω)	≤30 dB, 50 kHz to 6 MHz	With instrument turned on	19
Input to PIX MON output gain ratio	1:1 ±5% at 15 kHz		11

Table 1-2: DC Restoration

Characteristic	Requirement	Supplemental Information	Step Number
DC restorer clamp time		Back porch	
Frequency response at 60 Hz	Slow: 20% or less Fast: 90% or greater	Attenuation of 60 Hz on input signal	12
Blanking level shift with 10% to 90% APL change	APL changes from 50% to either 10% or 90% will cause blanking level shift of 1 IRE unit (7.14 mV) or less.		12
Blanking level shift due to presence or absence of burst	1 IRE unit (7.14 mV) or less shift from no color burst to presence of color burst.		12

Table 1-3: Calibrator

Characteristic	Requirement	Supplemental Information	Step Number
Frequency	100 kHz \pm 100 Hz	Synchronizes in 2H and 1H sweeps. Crystal controlled. Timing accuracy is 10 μ s, \pm 0.01 μ s. Can be used as 10 μ s and 1 μ s timing calibrator.	3
Amplitude	140 IRE (1 V) within 1%		10
Position		Top of waveform must be between 80 IRE (0.86 V) and 120 IRE (1.14 V) on graticule when backporch is positioned to 0 IRE (0.300 V) line, with DC RESTORER on.	

Table 1-4: Horizontal Deflection System

Characteristic	Requirement	Supplemental Information	Step Number
Sweep	Sweep occurs in all horizontal mode settings with or without synchronization.		5
2FLD sweep repetition rate	Equal to frame rate of applied video or external sync		
2FLD sweep magnification		Approximately X25	

Table 1–4: Horizontal Deflection System (Cont.)

Characteristic	Requirement	Supplemental Information	Step Number
1LINE sweep repetition rate	Equal to line rate of applied video or external sync		
2LINE sweep repetition rate	Equal to half line rate of applied video or external sync		
Sweep length		2LINE and 2FLD sweep length is nominally 12.5 divisions.	
Timing accuracy		All timing and linearity specifications exclude the first and last major divisions of the unmagnified display. Timing can be adjusted $\pm 5\%$ with front-panel H CAL.	
10 $\mu\text{s}/\text{div}$. (2LINE) sweep accuracy	Within 2%		6
5 $\mu\text{s}/\text{div}$. (1LINE) sweep accuracy	Within 2%		6
0.2 $\mu\text{s}/\text{div}$. (1LINE + MAG) sweep accuracy	Within 2%		6
Integral linearity	Within 1%	Measured between the 10 ms and 110 ms points on the 10 ms/division sweep. Calibrator transitions fall exactly on graticule marks.	6
Sweep magnifier registration		Magnification occurs about center of screen	
HORIZONTAL position	Any portion of a synchronized video sweep can be positioned on screen in all sweep modes.		

Table 1-4: Horizontal Deflection System (Cont.)

Characteristic	Requirement	Supplemental Information	Step Number
LINE SELECT	Displays the selected line in 1LINE. Displays the selected line first in 2LINE. Intensifies selected line in 2FLD. In 15LINE, displays overlaid lines in 1 or 2LINE, intensifies the selected 15 lines in 2FLD. A small 15 is added to the bottom of the CRT readout in 15LINE mode.		
Readout		NTSC: Field 1: Lines 1 to 263 Field 2: Lines 1 to 262 All: Lines 1 to 262 PAL Field 1: Lines 1 to 313 Field 2: Lines 314 to 625 All: Lines 1 to 312 PAL-M Field 1: Lines 1 to 263 Field 2: Lines 264 to 525 All: Lines 1 to 262	

Table 1-5: Synchronization

Characteristic	Requirement	Supplemental Information	Step Number
Input requirements, internal reference NTSC and PAL-M	Composite video or black burst with sync amplitudes 40 IRE ± 6 dB		4
PAL	Composite video or black burst with sync amplitudes 300 mV ± 6 dB		4
External reference	Sync amplitude between 143 mV and 4 V will synchronize sweeps		4
External reference, DC input impedance (unterminated)		Greater than 15 k Ω	
Return loss (75 Ω)	At least 40 dB from 50 kHz to 6 MHz	Loop-through terminated in 75 Ω , instrument power on or off	19
Absolute maximum input voltage		± 12 VDC plus peak AC	

Table 1–5: Synchronization (Cont.)

Characteristic	Requirement	Supplemental Information	Step Number
Remote sync Amplitude	2.0 to 5.0 V square wave, or 4.0 V comp sync	Input and enabled through rear-panel REMOTE connector. Input Impedance 1 MΩ. 30/60 Hz (25/50 Hz) square wave will sync 2FLD Sweep. Remote sync bypasses the sync stripper and field ID circuits.	
Sweep trigger polarity		Internal jumper selects polarity. Normal: Negative-going edge line sync, positive edge of field sync. Inverted: Positive-going edge line sync, negative edge of field sync.	
90/100 Hz triggering amplitude		2.0 to 5.0 V square wave	
90/100 Hz triggering frequency	NTSC: 90 Hz ±15% PAL: 100 Hz ±15%		9

Table 1–6: RGB/YRGB Mode

Characteristic	Requirement	Supplemental Information	Step Number
RGB/YRGB	Will display either a 3-step or 4-step RGB/YRGB parade or overlay display.	Internal jumper is used to change from 3-step to 4-step capability. Factory set to 3-step.	7
Staircase amplitude	A 10 V input will result in a horizontal display of 9 divisions ±1.4 major divisions.	Internal adjustment offsets any incoming signal DC component between ±12 V. Input impedance 1 MΩ shunted by approx. 3 pF.	7
Sweep repetition rate	Field or line rate of displayed video or external sync signal as selected by front-panel HORIZONTAL controls.	Field or line rate, if enabled from the REMOTE connector.	7
Control		RGB/YRGB mode and parade/overlay selected by applying ground (TTL low) at the RGB enable pin on the rear-panel REMOTE connector. RGB components may be overlaid with normal sweep length by not activating RGB enable.	
Magnifier		Approx. X25 for 2FLD, and X10 in 1 or 2LINE.	
Sweep length	3-step: 3.4 — 4.1 divs 4-step: 2.5 — 3.1 divs	Field or line rate sweeps. A 1FLD sweep is selected by grounding the 1FLD/1LINE pin of the rear-panel REMOTE connector.	7

Table 1–7: CRT Display

Characteristic	Requirement	Supplemental Information
CRT viewing area		80 X 100 mm Horizontal = 12.5 div Vertical = 170 IRE units (1.19 V)
Accelerating potential		Nominally 13.75 kV
Trace rotation range	Greater than $\pm 1^\circ$ from horizontal	Total adjustment range is typically 8°
Graticule		Internal, variable illumination

Table 1–8: Power Source

Characteristic	Requirement	Supplemental Information
Mains voltage range	90 – 250 V	Continuous range from 90 to 250 VAC
Mains frequency		50 or 60 Hz
Power consumption		56 VA (35 Watts)

Table 1–9: Environmental Characteristics

Characteristic	Requirement
Operating temperature	0 to 50 °C (+32 to 122 °F)
Storage temperature	–40 to 75 °C (–40 to 158 °F)
Operating altitude	To 15,000 feet (4572 meters)
Storage altitude	To 50,000 feet (15,240 meters)
Vibration	5 minutes at 5 - 15 Hz with 0.060 inch displacement. 5 minutes at 15 - 25 Hz with 0.040 inch displacement. 5 minutes at 25 - 55 Hz with 0.020 inch displacement. Military Specification: Mil-T-28800D, Paragraph 1.2.2, Class 3.
Mechanical shock	Non operating: 50 g's 1/2 sine, 11 ms duration, 3 shocks per surface (18 total).
Transportation	Qualified under NSTA Test Procedure 1A, Category II (24 inch drop).
Humidity	Will operate at 95% relative humidity for up to five days. Do not operate with visible moisture on the circuit boards.

Table 1–10: Certifications and Compliances

Category	Standards or Description
EC Declaration of Conformity – EMC ¹	<p>Meets intent of Directive 89/336/EEC for Electromagnetic Compatibility. Compliance was demonstrated to the following specifications as listed in the Official Journal of the European Union:</p> <p>EN 50081-1 Emissions: EN 55022 Class B Radiated and Conducted Emissions</p> <p>EN 50082-1 Immunity: IEC 801-2 Electrostatic Discharge Immunity IEC 801-3 RF Electromagnetic Field Immunity IEC 801-4 Electrical Fast Transient/Burst Immunity</p> <p>¹ High-quality shielded cables must be used to ensure compliance to the above listed standards.</p> <p>This product complies when installed into any of the following Tektronix instrument enclosures:</p> <p style="padding-left: 40px;">1700F00 Standard Cabinet 1700F02 Portable Cabinet 1700F05 Rack Adapter</p>
Australia/New Zealand Declaration of Conformity – EMC	<p>Complies with EMC provision of Radiocommunications Act per the following standard(s):</p> <p>AN/NZS 2064.1/2 Industrial, Scientific, and Medical Equipment: 1992 AN/NZS 3548 Information Technology Equipment: 1995</p>
FCC Compliance	<p>Emissions comply with FCC Code of Federal Regulations 47, Part 15, Subpart B, Class A Limits.</p>
Installation (Overvoltage) Category	<p>Terminals on this product may have different installation (overvoltage) category designations. The installation categories are:</p> <p>CAT III Distribution-level mains (usually permanently connected). Equipment at this level is typically in a fixed industrial location.</p> <p>CAT II Local-level mains (wall sockets). Equipment at this level includes appliances, portable tools, and similar products. Equipment is usually cord-connected.</p> <p>CAT I Secondary (signal level) or battery operated circuits of electronic equipment.</p>
Pollution Degree	<p>A measure of the contaminates that could occur in the environment around and within a product. Typically the internal environment inside a product is considered to be the same as the external. Products should be used only in the environment for which they are rated.</p> <p>Pollution Degree 1 No pollution or only dry, nonconductive pollution occurs. Products in this category are generally encapsulated, hermetically sealed, or located in clean rooms.</p> <p>Pollution Degree 2 Normally only dry, nonconductive pollution occurs. Occasionally a temporary conductivity that is caused by condensation must be expected. This location is a typical office/home environment. Temporary condensation occurs only when the product is out of service.</p> <p>Pollution Degree 3 Conductive pollution, or dry, nonconductive pollution that becomes conductive due to condensation. These are sheltered locations where neither temperature nor humidity is controlled. The area is protected from direct sunshine, rain, or direct wind.</p>

Table 1–10: Certifications and Compliances (Cont.)

Category	Standards or Description	
	Pollution Degree 4	Pollution that generates persistent conductivity through conductive dust, rain, or snow. Typical outdoor locations.
Safety Standards		
U.S. Nationally Recognized Testing Laboratory Listing	UL1244	Standard for electrical and electronic measuring and test equipment.
Canadian Certification	CAN/CSA C22.2 No. 231	CSA safety requirements for electrical and electronic measuring and test equipment.
European Union Compliance	Low Voltage Directive 73/23/EEC, amended by 93/69/EEC EN 61010-1	Safety requirements for electrical equipment for measurement, control, and laboratory use.
Additional Compliance	IEC61010-1	Safety requirements for electrical equipment for measurement, control, and laboratory use.
Safety Certification Compliance		
Temperature, operating	+5 to +40° C	
Altitude (maximum operating)	2000 meters	
Equipment Type	Test and measuring	
Safety Class	Class 1 (as defined in IEC 1010-1, Annex H) – grounded product	
Overvoltage Category	Overvoltage Category II (as defined in IEC 1010-1, Annex J)	
Pollution Degree	Pollution Degree 2 (as defined in IEC 1010-1). Note: Rated for indoor use only.	

Table 1–11: Physical Characteristics

Characteristic	Requirement
Dimensions	Height: 5 1/4 inches (133.4 millimeters) Width: 8 1/2 inches (215.9 millimeters) Depth: 18 1/8 inches (460.4 millimeters)
Weight	Net: 8.5 pounds (3.8 kilograms)



Operating Instructions

Section 2

Operating Instructions

These instructions provide information about the front-panel controls, rear-panel connectors, graticules, and an Operator's Familiarization / Checkout Procedure, along with measurement discussions.

Front-Panel Controls and Indicators

The front-panel controls and indicators consist of momentary contact push-button switches, variable controls, and backlit switch selections. See Figure 2-1 for control and indicator locations. When Line Select is being used, the field and line numbers are displayed on the CRT for field rate sweeps; a strobe pulse is applied to displays of 2 field rate sweep to identify the selected line.

There are eight push-button switches that have functions that are accessed by holding the switch down for approximately one second. These functions are identified by a blue box surrounding the front-panel label. The DC Restorer switch toggles between FAST and SLOW when it is pushed and held. When exiting a held mode the selection reverts to the top of the list at the touch of the push button, with the exception of the REF switch, which returns to its previous setting.

1 INPUT FILTER

Toggles through three positions, FLAT, LPASS, and CHROMA. In 2LINE or 2FLD SWEEP a combination filtering routine, consisting of Low Pass and Flat for alternate lines or fields, can be accessed by holding the FILTER push button switch in. In the dual filter mode the low pass filtered line or field will always be on the left in 2LINE or 2FLD SWEEPS. Lines are overlaid in 1LINE SWEEP. The dual filter can not be accessed when the 1730-Series is in AB switching or Line Select mode.

Filtering always returns to FLAT when coming out of the combination filtering routine. If AB switching or LINE SELECT is selected after the dual filter mode, filtering will be low pass.

2 REF

Toggles between internal and external reference. Calibrator is accessed by holding in the REF switch. Instrument status is retained in memory when CAL is selected and the original status restored when the push button is again pushed. All front-panel lights, except SWEEP and MAG, go out and GAIN goes to X1 when the calibrator is selected. The X5 and VAR GAIN are usable with the

calibrator. CAL cannot be Stored or Recalled. (Note that MAG and SWEEP are switchable in the Calibrator mode but revert to their previous setting when the mode is exited.)

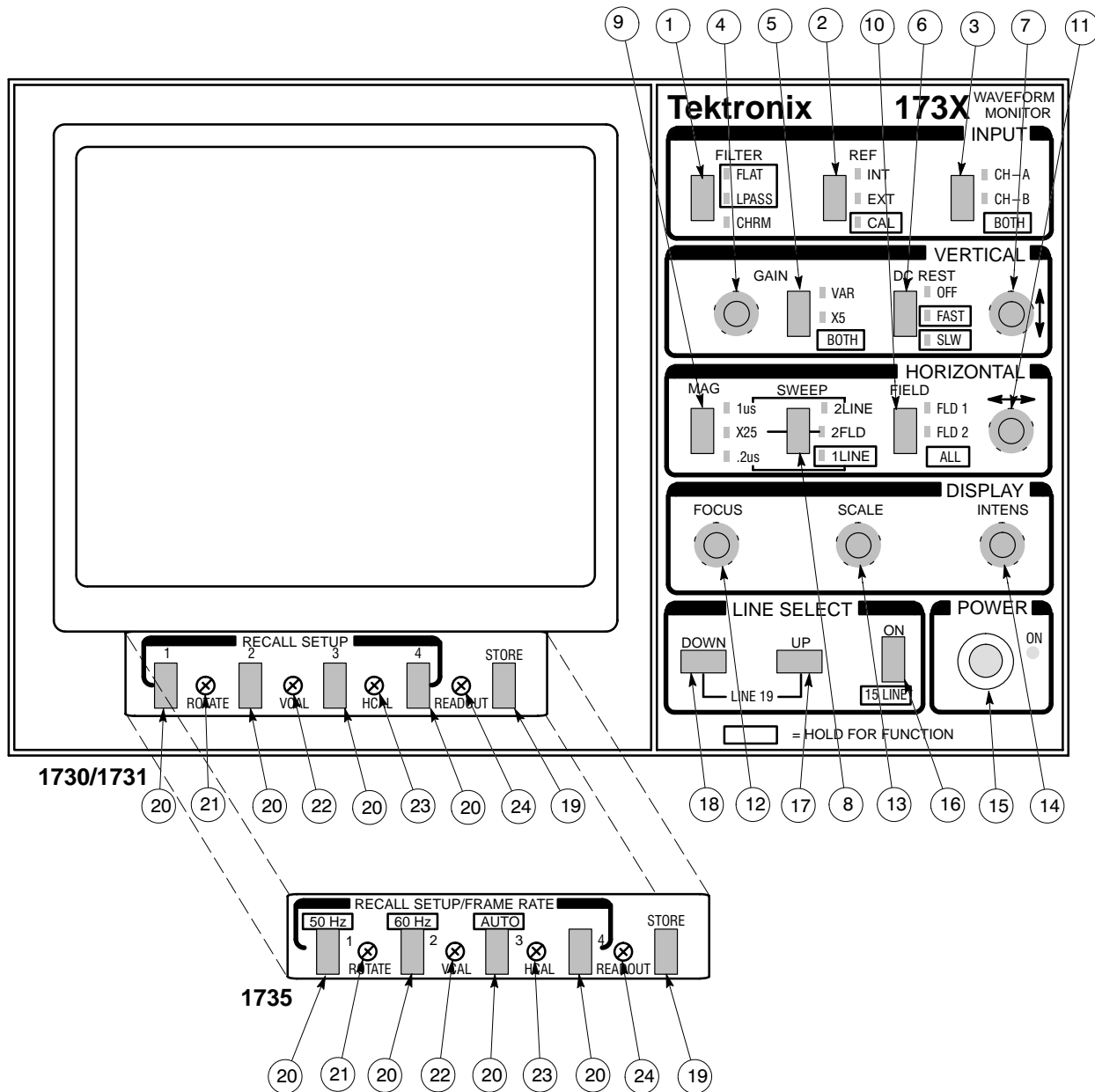

Figure 2-1: 1730-Series front-panel control locations. Front panels are identical for the 1730 and 1731. Inserted CRT panel identifies the different switch functions for the 1735.

3 CH-A-CH-B

Switch that toggles between Channel A and Channel B input. When held, the 1730-Series goes into an AB (BOTH) alternate mode, with the A input on the left and the B input on the right in 2 Line or 2 Field (lines are overlaid in 1 Line sweep). When in the AB switching mode the REF is forced to EXT, the FILTER is forced to LPASS, if it was in the LPASS-FLAT switching mode; if not the FILTER remains in the previous position, and the DC REST goes to SLOW. All three functions go back to their previous setting when the input is switched out of AB. The DC Restorer can be changed after entering the AB mode. When leaving (BOTH), the input always returns to CH-A.

4 GAIN (control)

Enabled when the GAIN switch is in VAR. Adjusts amplifier input gain rate to make any input waveform signal, between 0.8 and 2.0 V peak-to-peak a full-scale display. Control has no detent.

5 VERTICAL GAIN (Switch)

Toggles between VAR, X5, and off. A BOTH mode consisting of VAR and X5 is accessed by holding the push button until both LED indicators are lit.

6 DC REST

Toggles the DC Restorer on and off. When turned on the restorer comes up as previously selected, in either the SLOW or FAST position. Pushing and holding the switch in toggles the restorer between FAST and SLOW. Once the restorer speed has been selected, pushing the DC REST button turns the DC Restorer on, at the selected speed, or off.

7 POSITION

Variable control that positions the waveform display vertically.

Horizontal

8 SWEEP

Toggles between 2LINE and 2FLD Sweep. 1LINE Sweep is accessed by holding the SWEEP push button in until recognition occurs. The MAG is automatically turned off if SWEEP is changed. Sweep rates are as follows:

2LINE unmagnified = 10 μ s/div

1LINE unmagnified = 5 μ s/div

9 MAG

Toggles between on and off. Operates in conjunction with the SWEEP mode to provide usable sweep rates as follows:

$$2\text{LINE} + \text{MAG} = 1 \mu\text{s}/\text{div}$$

$$2\text{FLD} + \text{MAG} = 1 \text{ full vertical interval}$$

$$1\text{LINE} + \text{MAG} = 0.2 \mu\text{s}/\text{div}$$

The vertical interval displayed in 2FLD MAG is the one following the selected field trigger; for example, if FLD 1 is selected as the trigger, the vertical interval displayed is the one between field 1 and field 2 (field 2 interval).

10 FIELD

Toggles between FLD 1 and FLD 2. The ALL mode is accessed, in the LINE SELECT mode, by holding the FIELD push button in until the word ALL appears on the CRT readout for 2LINE or 1LINE sweep or a bright-up strobe appears in both fields for 2FLD sweep.

This switch determines which field triggers the 2FLD sweep. The selected field trigger is the first (left) field displayed. For example, selecting Field 2 trigger places field 2 on the left, followed by field 1.

In LINE SELECT, the indicator lights go off but triggering of the 2FLD sweep continues on the selected field. A line strobe identifies the selected line. In 1LINE or 2LINE sweep, the FIELD button determines the field from which the selected line is displayed (field 1, field 2, or ALL fields). When exiting ALL fields display, switching defaults to FLD 1.

11 POSITION

Variable control that positions the waveform display horizontally.

Display

12 FOCUS

Adjusts CRT beam for optimum definition.

13 SCALE

Controls the level of graticule illumination.

14 INTENSITY

Controls display brightness.

Power

15 ON

Switches between instrument in a powered up state and in standby. Portions of the power supply circuit board still have mains potential on them. A mechanical indicator in the center of the switch shows the status of the POWER switch.



WARNING. *Power Supply Hazard:*

Mains power is still applied to the 1730-Series power supply circuit board, regardless of POWER switch state. To totally remove shock hazard it is necessary to unplug the instrument and wait for capacitors to discharge.

Line Select

16 ON

Toggles between ON and OFF. Line and field number are displayed on the CRT in 1LINE or 2LINE sweep rates with a colon as a delimiter, for example: F1:19 (field 1, line 19). In LINE SELECT mode, the selected line is displayed in 1LINE sweep rate, the selected line is displayed first in the 2LINE sweep rate, and a bright-up is provided to mark the selected line in 2FLD sweep rate. The field from which the line will be displayed can be selected with the FIELD switch.

15 LINE display is accessed by holding the LINE SELECT ON button until there is recognition. In 2FLD, the 15 lines are intensified in the display. In 1 or 2LINE sweeps, the 15 lines are overlaid and the CRT readout is active, giving the field and line of the first displayed line plus a small 15 immediately below the colon in the readout.

Lines displayed in the LINE SELECT mode have their active video intensified on the PIX MON OUT signal.

17 UP

Increments the line count (when enabled). Holding the UP push button in increments faster.

18 DOWN

Decrements the line count (when enabled). Holding the DOWN push button in decrements faster.

Holding either button down until the count passes the beginning or end of the field causes the count to shift to the other field.

(When LINE SELECT is enabled, holding in both the UP and DOWN push buttons returns the line count to Field 1, Line 19.)

Recall Setup

19 STORE

Enables the storage of front–panel settings, including line number, in four different memory locations. To Store a front–panel setup, the STORE switch is pushed and then one of the four RECALL SETUP switches is pushed. When STORE is pushed, all front–panel lights cycle off and on (approximately 15 times) to indicate that the front–panel, as it is currently set up, can be Stored. If the current selection is not the desired setup, pushing any front–panel button, except a RECALL SETUP, will cancel the STORE mode. If one of the RECALL SETUP switches is pushed while STORE is active, the current front–panel setup will be stored in the selected RECALL position. CAL cannot be Stored.

When a Store operation is performed on the 1735, the selected standard (50 Hz, 60 Hz, or AUTO) is stored.

20 RECALL SETUP (1–2–3–4)

Recalls from memory, or causes the storage in memory of a (1–2–3–4) front–panel setting. Each of the four switches operates with a memory location and the STORE push–button switch.

A special feature in the 1735 allows the operator to use the Store and Recall function in the normal manner, or to select from three operating modes by holding the RECALL switches. The 50 Hz (PAL) standard of operation is selected by holding the Recall Setup 1 button and 60 Hz is selected with the Recall Setup 2 button. AUTO, which provides automatic switching between the two standards, is selected with the Recall Setup 3 button. In non–line select modes of operation, holding the Recall Setup 4 button will display the status of the current standard.

If 50 Hz or 60 Hz operation has been Stored as a setup, it will be recalled by pushing a RECALL switch. If the AUTO mode of operation is Recalled, and a change in input signal standard has occurred, the 1735 will recall the correct

standard (after the slight delay associated with automatic determination of the reference standard).

Miscellaneous

21 ROTATE

A 270° screwdriver adjustment that aligns the display with the graticule.

22 V CAL

A 270° screwdriver adjustment that sets the vertical amplifier gain. Is normally used with the CAL position of the REF switch.

23 H CAL

A 270° screwdriver adjustment that sets the timebase. Can be used accurately with the CAL position of the REF switch in the 2H Sweep.

24 READOUT

A 270° screwdriver adjustment used to change the brightness of the readout portion of the CRT display relative to the waveform intensity.

Rear-panel Connectors

Signal input, power input, RGB input, Remote Sync Input, Picture Monitor Out, Auxiliary Control Output, and Remote Control are all located on the 1730-Series rear panel. Because of the similarity of the 1730- and 1720-Series rear panels, WAVEFORM MONITOR is printed on the 1730-Series rear panel. See Figure 2-2 for the locations of the rear-panel connectors.

Bnc Connectors

1 CH-A

Bridging loop-through composite video input, compensated for 75Ω. This input is selected for display by the front-panel INPUT switch.

2 CH-B

Bridging loop-through composite video input, compensated for 75Ω. This input is selected for display by the front-panel INPUT switch.

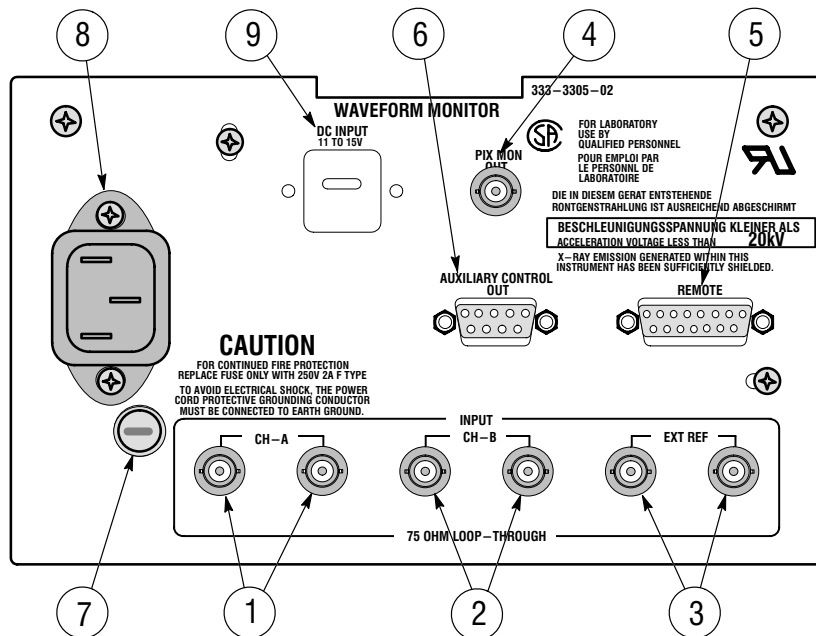

Figure 2-2: 1730-Series rear panel.

3 EXT REF

Bridging loop-through synchronization input (compensated for 75Ω), selected as the synchronizing source by the front-panel REF switch. The input signal may be composite sync, black burst, or composite video.

4 PIX MON OUT

A 75Ω, unfiltered, output signal that corresponds to the front-panel selected display. This signal has bright-up, in the LINE SELECT mode, and is used to drive a picture monitor.

Multi-Pin Connectors

5 REMOTE

A 15-pin, D-type, female connector that provides limited remote control functions, such as four factory-preset front-panel setups, store disable, and the input connector and enable for the RGB/YRGB staircase.

Remote functions are activated by polled ground closure; only changes in remote input are responded to, allowing the front panel to be fully operational.

6 AUXILIARY CONTROL OUT

A 9-pin, D-type, female connector to interface with the 1720-Series. Auxiliary control consists of a signal line and an interface bus. The bus provides the 1730-Series with control of the 1720-Series Vectorscope.

Power Input

7 AC FUSE

Holder for the instrument's mains fuse.

8 AC POWER

A standard ac plug receptacle for 120 or 240 Vac power mains. Plug is compatible with any of the three power cord options available for the 1730-Series Waveform Monitor.

9 DC INPUT

A knockout for installation of a 1700F10 Field Upgrade Kit dc power plug.

Operator's Checkout Procedure

The following procedure is provided as an aid in obtaining a display on the 1730-Series Waveform Monitor (operator familiarization), and as a quick check of basic instrument operation. Only instrument functions, not measurement quantities or specifications, are checked in this procedure. Therefore, a minimum amount of test equipment is required. All checks are made with the cabinet on and all internal jumpers in the factory-set position.

If performing the Operator's Checkout Procedure reveals improper operation or instrument malfunction, first check the operation of associated equipment. If associated equipment is performing normally, refer the 1730-Series Waveform Monitor to qualified service personnel for repair or adjustment.

When a complete check of the instrument performance to its specification is desired, refer to the Performance Check (which should only be performed by qualified service personnel) in Section 5 of this manual.

This procedure requires a source of composite video. The TEKTRONIX 1410-Series Television Test Signal Generator (1410 for NTSC, 1411 for PAL, or 1412 for PAL-M) with Sync, Color Bar, and Linearity modules was used in preparing this procedure.

Procedure This procedure requires only one hook-up to perform. Figure 2-3 shows the required connections. Once the connections are made, continue on to step 1 of the procedure.

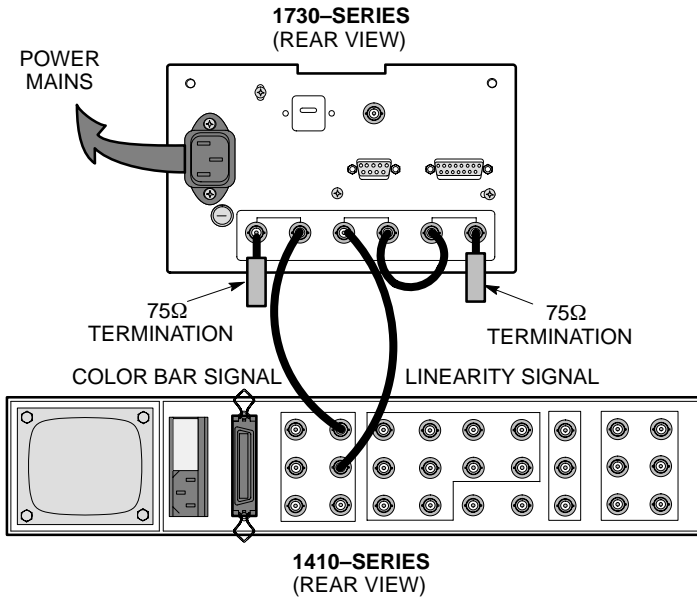

Figure 2-3: Equipment connections for the 1730-Series "Operator's Checkout Procedure."

1. Initial Generator Setup

Video Signal Generator – Test Signals

Full Field Color Bars

75% Ampl. 7.5% Setup – NTSC and PAL-M

75% Ampl. 0% Setup – PAL

Modulated Staircase

(Flat Field, 5 Step)

2. Apply Power

Connect the instrument to a suitable ac power source and push the POWER button. A center dot should appear in the eye of the POWER switch to indicate that it is on.

NOTE. *Front-panel screwdriver adjustments:*

Do not set any of the front-panel screwdriver controls until after the instrument warms up (20 minutes minimum).

3. Initial Front-Panel Setup

1730-Series Waveform Monitor

FILTER	FLAT
REF	INT
INPUT	A
GAIN	OFF (no indicators on)
POSITION VERTICAL	as is
DC REST	OFF
SWEEP	2LINE
MAG	OFF (no indicators on)
LINE SELECT	OFF (no line number readout on CRT)
FIELD, HORIZONTAL POSITION, FOCUS, SCALE, INTENS, DOWN, UP, and RECALL SETUP all as they are.	
Screwdriver adjustments (ROTATE, V CAL, H CAL, and READOUT) should not be adjusted until directed in procedure.	
POWER	ON

4. Obtain Display

Adjust the INTENS and FOCUS controls for the desired brightness and a well-defined display. Adjust the multi-turn VERTICAL Position control to place the display blanking level on the graticule 0 IRE (NTSC and PAL-M) or 300 mV (PAL) line. Center the display with the HORIZONTAL Position. See Figure 2-4.

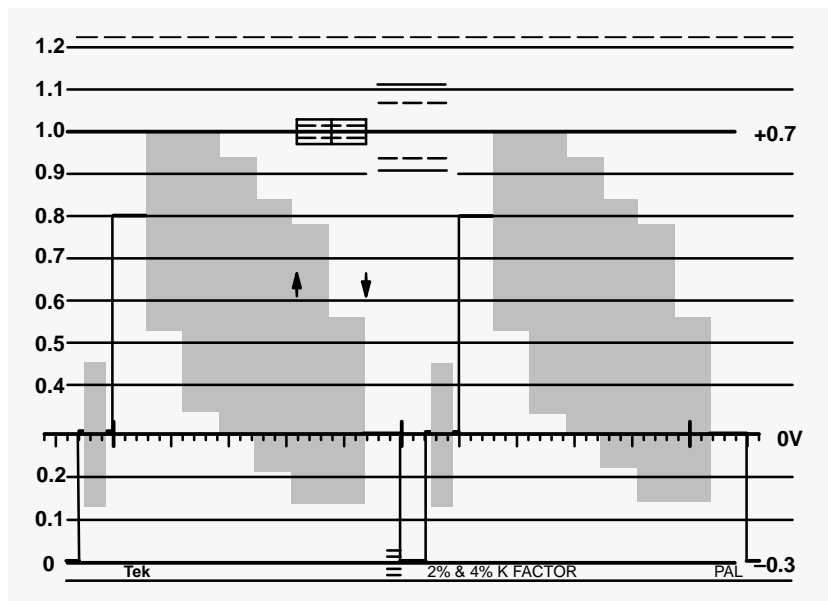

Figure 2-4: Two-line color bar display in FLAT filter mode.

Adjust the SCALE illumination control for the desired graticule scale brightness.

5. Check the Rotation of the Display

Variations in the earth's magnetic field may make adjustment of the ROTATE control necessary at installation time or whenever the instrument is moved.

Check that the display blanking level is parallel to the horizontal axis. If not, adjust the ROTATE screwdriver adjustment until the sweep is parallel to the horizontal axis.

6. Calibrate Display

The CAL mode on the REF switch enables the waveform monitor calibrator signal.

Press and hold the REF button until the CAL indicator LED is lit. Adjust the VERTICAL and HORIZONTAL Position controls to obtain a display similar to that shown in Figure 2-5.

If necessary, adjust the V CAL screwdriver control for 1 V amplitude (140 IRE). Switch REF to INT mode.

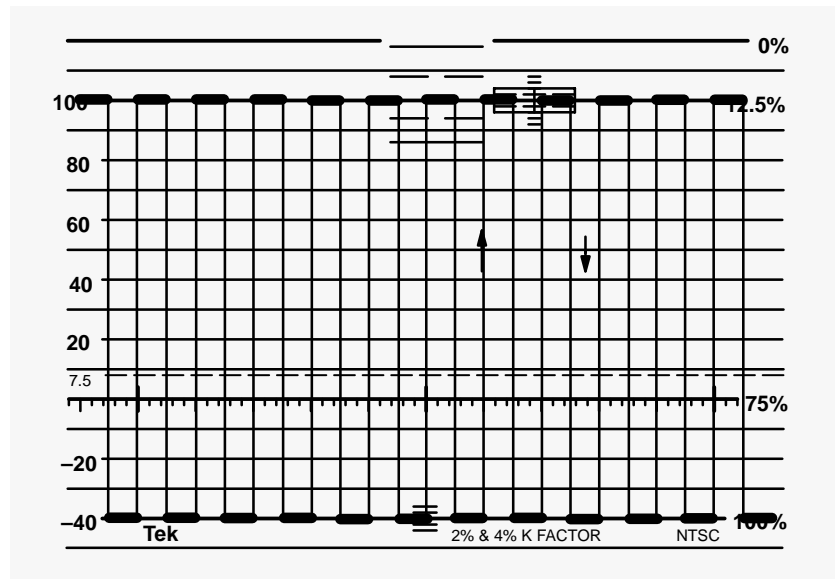

Figure 2-5: Checking vertical gain calibration with the 1730-Series internal calibrator (CAL) reference.

7. Select Input

The AB switch selects the rear-panel Channel A or Channel B inputs. Position the color bar waveform so that the blanking level is at the -40 IRE (0 V) graticule line and the sync pulses are at each end of the graticule.

Select the Channel B input. Note that the linearity waveform is displayed.

Push and hold the INPUT button until both the color bar and linearity waveforms are displayed. See Figure 2-6. Check that both the CH-A and CH-B front-panel indicators are on.

Push the switch to return to the Channel A (color bar) display.

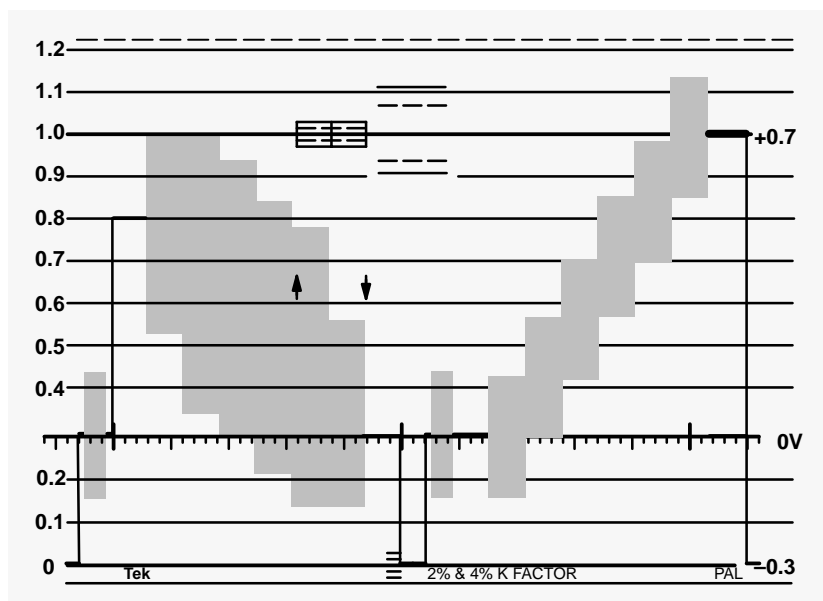

Figure 2-6: Dual channel, 2-line display of color bar and linearity signals.

8. Select Timing Reference

Be sure that SWEEP is still 2LINE. Hold the REF button in until the CAL signal appears. Position it so the top of the display is on the 70 IRE (NTSC and PAL-M) or 0.7 V (PAL). Horizontally position the display so the first transition is on the left side timing mark (the mark that goes completely through the blanking line. There are three on the graticule.) See Figure 2-7a. Check that the falling transition of the 10th square wave passes directly through the right side timing mark. The H CAL can be adjusted if timing is off. Push the MAG button and check for one cycle of square wave over the 10 divisions of timing area. See Figure 2-7b.

Hold the SWEEP button until the 1LINE front-panel indicator lights. Check for five full cycles over the 10-division timing area. See Figure 2-7c.

Push the waveform monitor REF switch and return to INT.

9. Gain Control

The normal GAIN setting (with the GAIN switch off) is 1 V full scale with neither the X5 nor the VAR indicator lit. The GAIN (VAR) control changes the amplifier gain so that signals greater or lesser in amplitude to the calibrated 1 volt full scale can be displayed as full scale.

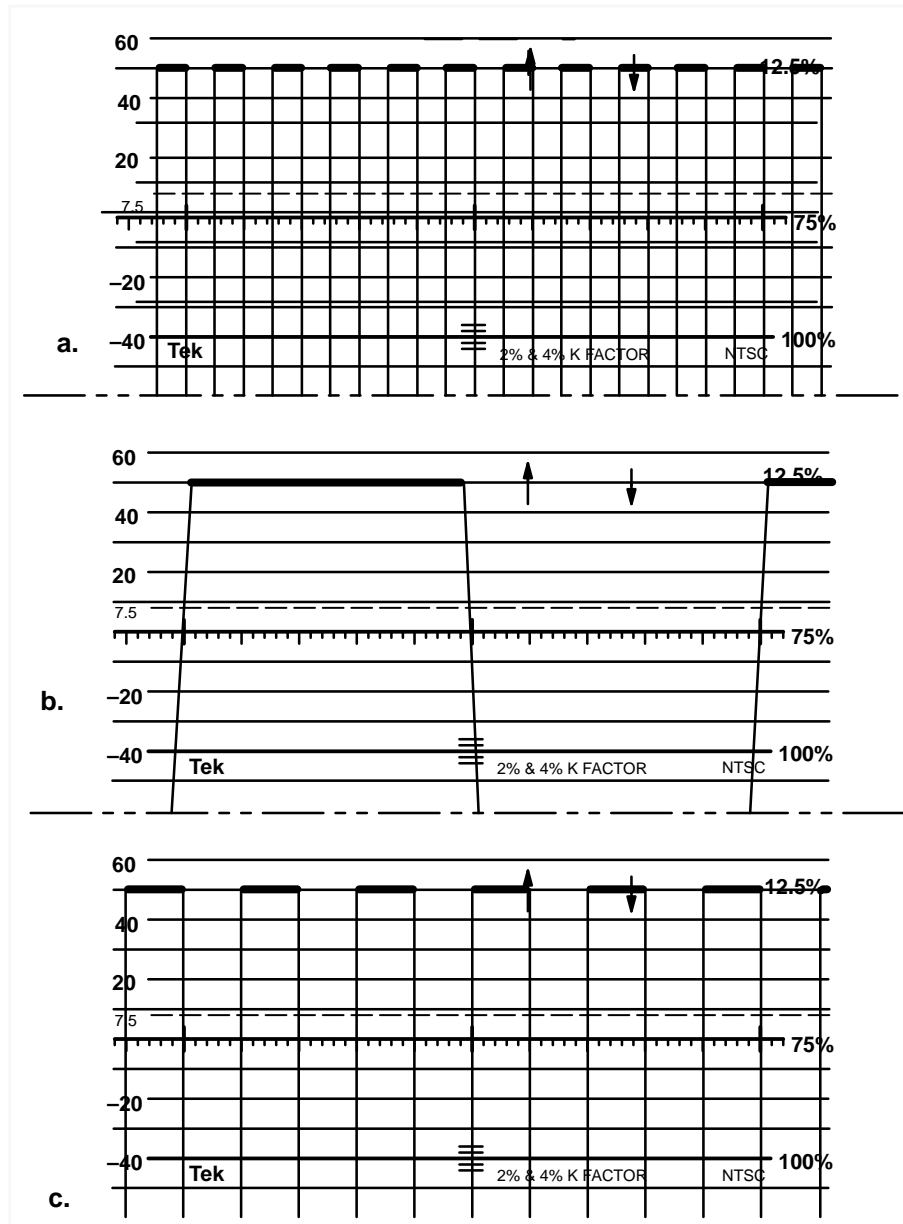

Figure 2-7: Checking timing with the internal calibrator signal: a) 2-line display. b) 2-line display magnified. c) 1-line display.

Push the GAIN switch and note that the VAR indicator is lit. Also note the range of amplitude (signal amplitude greater than the scale at one extreme and considerably smaller at the other) that is obtained with the control.

Push the button and check that the X5 indicator lights. Check for a large increase in gain. (It can be determined that this is a X5 gain increase by setting the signal base line on the graticule 0 IRE (NTSC and PAL-M) or 300 mV

(PAL) and checking that the maximum excursion of color burst is at approximately the 100 IRE or 1 V graticule line.)

Push the button in and hold it until both the VAR and X5 indicators are lit. Rotate the GAIN control and look for a greater than 5X amplitude display at one extreme and a nearly normal amplitude display at the other extreme.

Push the GAIN button once and notice that the display amplitude returns to 1 V Full Scale.

10. Filter Selection

The FILTER button selects the frequency response characteristic for the displayed signal. The FLAT response is used for normal applications. Figure 2-4 shows the color bar signal with the FLAT response.

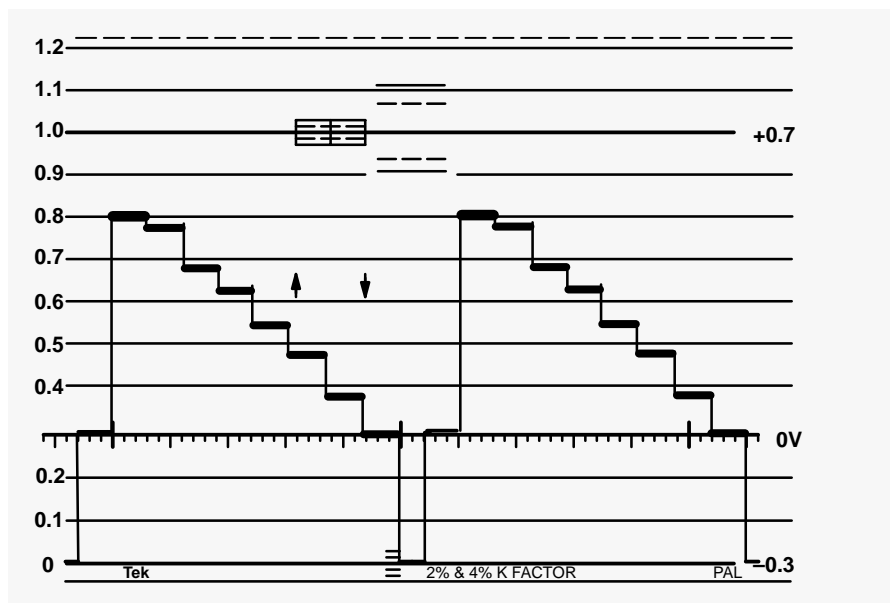

Figure 2-8: Two-line display of color bar signal with LOW PASS filter on.

Press and hold the FILTER button to get the front-panel LPASS indicator to light. This provides the low pass frequency response; the chrominance component of the signal has been removed. See Figure 2-8.

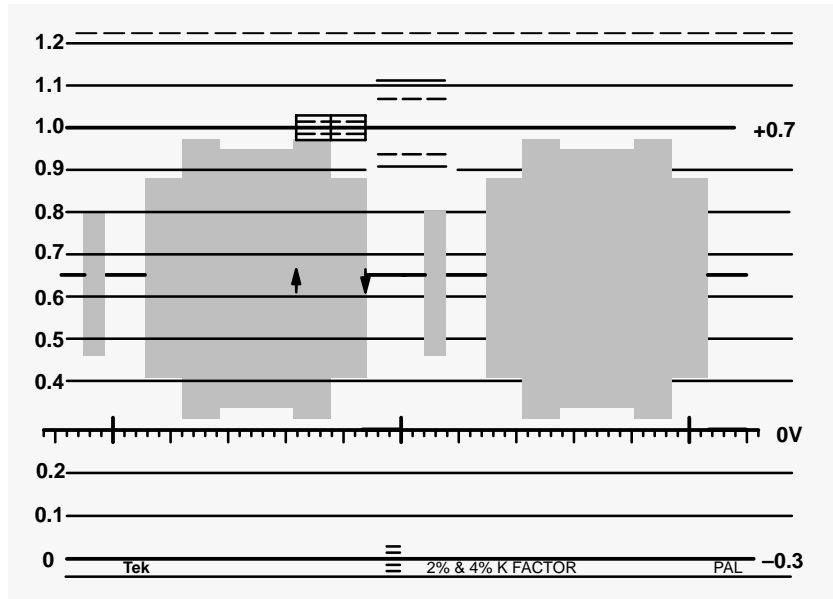

Figure 2-9: Two-line display of color bar signal with CHROMA filter.

Press the FILTER button once more and look to see that the CHROMA indicator is lit. The signal is now displayed as chrominance only; the luminance component is removed. See Figure 2-9.

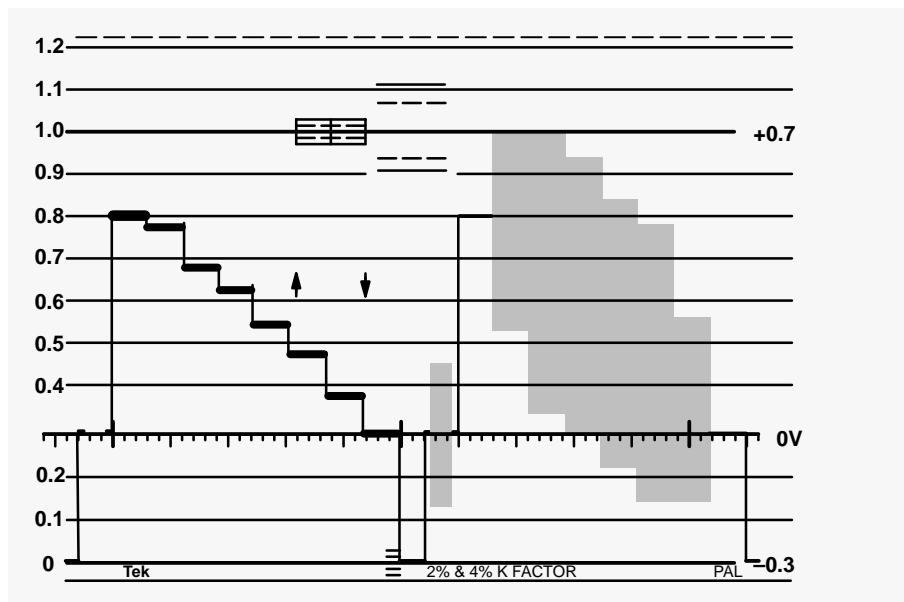

Figure 2-10: Two-line display with dual filter selected (LOW PASS and FLAT).

Hold the FILTER button in until both the FLAT and LPASS front-panel indicators are lit. The display now consists of two lines, the first of which has the chrominance removed and the second is unfiltered. See Figure 2-10.

Push the FILTER switch and return to FLAT.

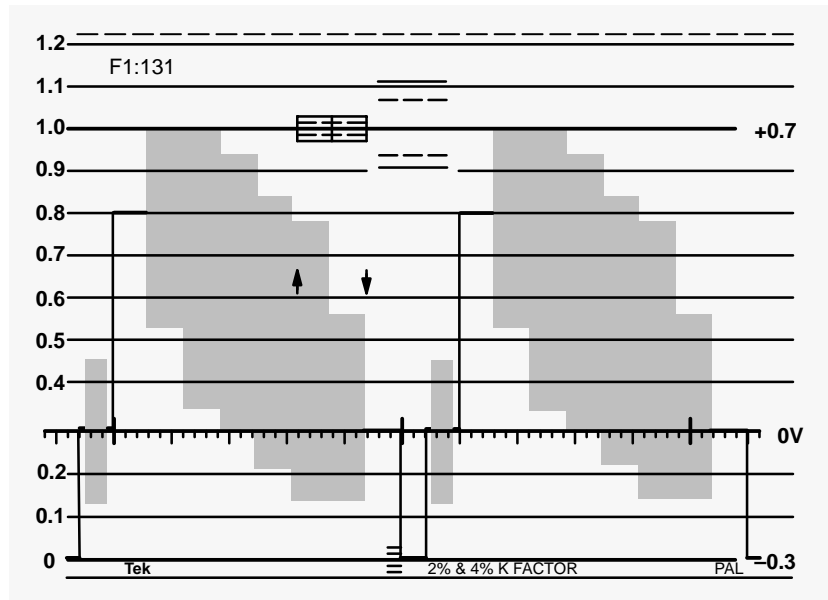

Figure 2-11: Two-line display with LINE SELECT on. Note readout in upper left corner.

11. Sweep Speeds and Line Select

Turn on LINE SELECT and push and hold both the UP and DOWN buttons until the readout indicates that line 19 of field 1 is being displayed. Use the LINE SELECT UP or DOWN button to display line 131 (see Figure 2-11). Holding in the UP or DOWN button causes the counter to move faster.

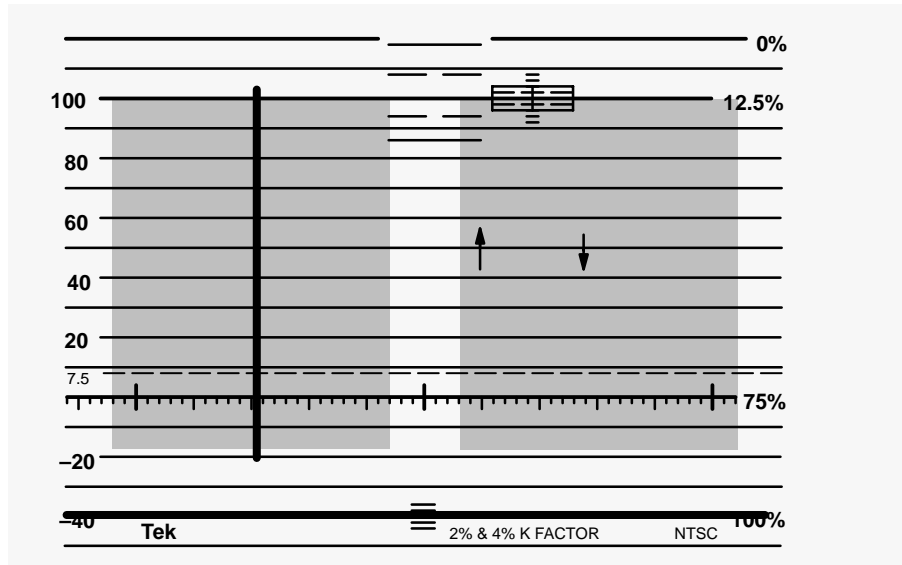

Figure 2-12: Two-field display with intensified line in the first displayed field.

Push the sweep button and observe the 2FLD Sweep with an intensified line at the mid point of one of the fields (see Figure 2-12). This intensified line is located at the line just viewed in the 2-line display. Push and hold the LINE SELECT button until the intensified portion of the display increases in width; this is the 15 Line mode of LINE SELECT. See Figure 2-13.

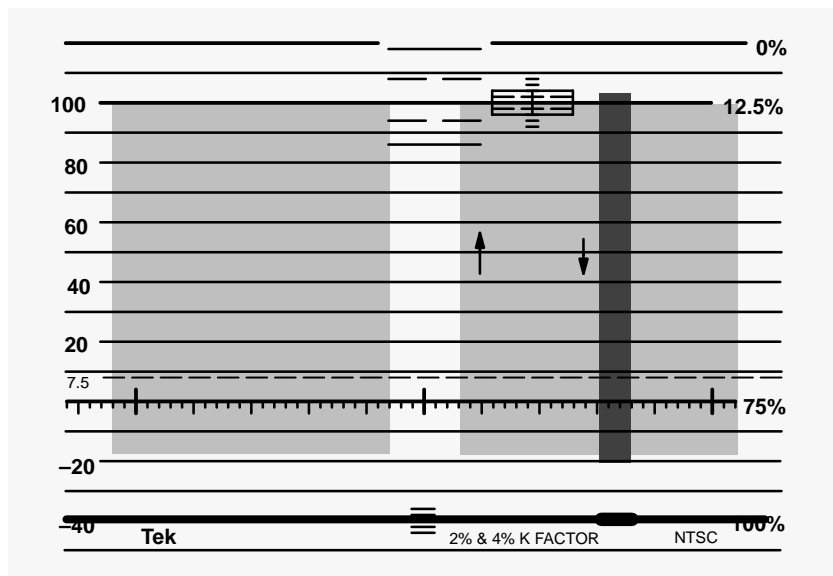

Figure 2-13: Two-field display with 15 line mode of the LINE SELECT on.

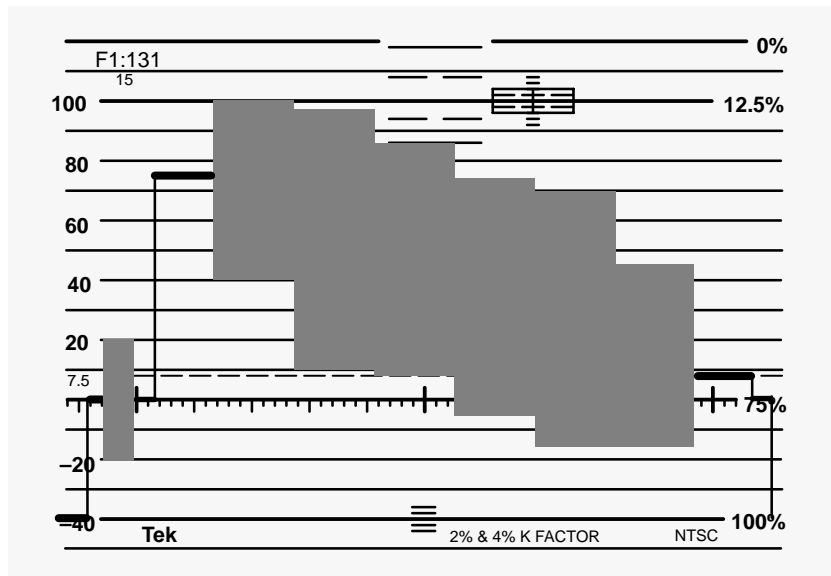

Figure 2-14: A 1-line sweep rate with 15 continuous lines (from mid field) displayed using LINE SELECT.

Push and hold the SWEEP button until the front-panel 1LINE indicator lights. Look for a display of one line, with a readout that shows F1 or F2:131 over 15 (see Figure 2-14). This is the 15 continuous lines which were intensified in the 2-field display, overlaid in a one-line display. The readout shows that these 15 lines are in field 1 or field 2, starting with line 131. Change the field by pushing the FIELD button. Turn off LINE SELECT.

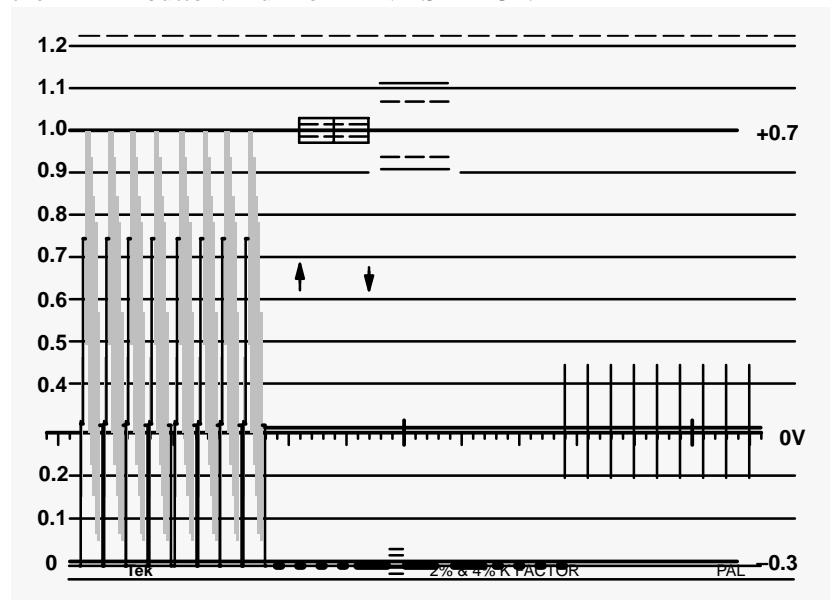

Figure 2-15: Display of vertical interval with magnified 2 field sweep.

12. Horizontal Magnifier

Select the 2LINE SWEEP and center the horizontal sync on the screen. Press the MAG button and note the magnification of the horizontal sync details. Push SWEEP for 2FLD and MAG for X25 and note that the vertical interval is displayed. See Figure 2-15. Note that the MAG button works with any SWEEP selection. Push the MAG button to turn off the MAG.

13. Recall Setup

Set the 1730-Series for both CH-A and CH-B input, SWEEP to 1LINE, MAG on, and VERTICAL GAIN to X5. Note front-panel indicators. Push the RECALL SETUP 1 button and note that the front-panel setup changes.

NOTE. Do not attempt to STORE:

The Store function could also be checked; however, operating settings may be stored in the memory location, and they would be overwritten with the new front-panel information. For more information on how to use the Store function, see CONTROLS and CONNECTORS in this section of the manual.

Graticules

There are three basic graticule patterns available for the 1730-Series. All three are internal with edge illumination. The graticule used by both the 1730 and the 1731 PAL-M is a 525 line/60 Hz NTSC Composite scale. The 1731 PAL has the CCIR 625 line/ 50 Hz graticule for the PAL color standard. The 1735 has a dual graticule which accommodates both NTSC and PAL scales.

Because the internal graticule is on the same plane as the CRT phosphor it eliminates viewing and photographic parallax errors. The graticule is illuminated, using a front-panel SCALE adjust control, so that the level of graticule brightness can be adjusted to optimum for viewing or photographing needs.

The major differences between the NTSC and PAL graticules are in the vertical scales. In the paragraphs that follow each of the vertical graticule scales will be discussed separately, while the horizontal scales are discussed together.

NTSC Composite Video Graticule Vertical Scales

The NTSC graticule has two main vertical scales to facilitate typical measurements. See Figure 2-16. The left side scale is marked in IRE units and extends from -50 to +120 IRE in 10 IRE increments. An IRE unit is equal to 7.14 millivolts. Black level setup is denoted by a dashed line at 7.5 IRE.

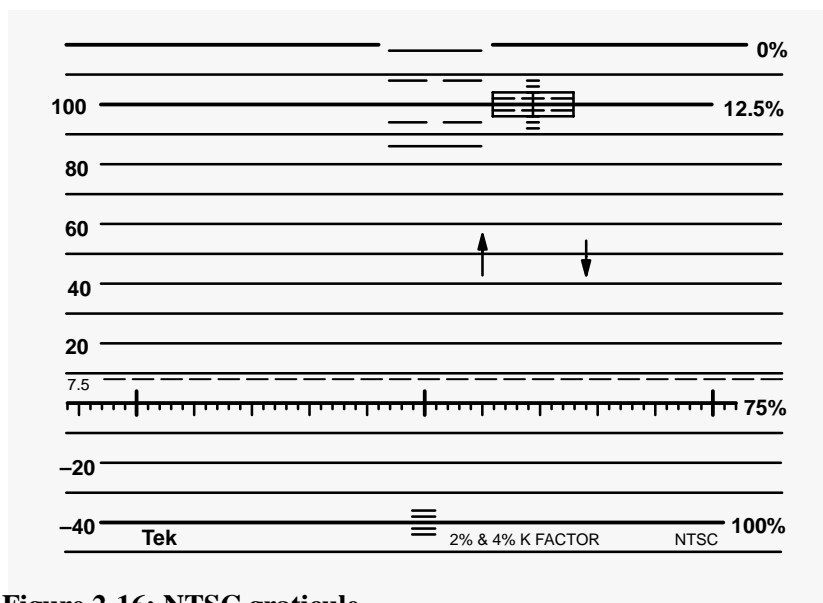

Figure 2-16: NTSC graticule.

There are ± 2 IRE and ± 4 IRE markings at the center of the -40 IRE line (sync tip) to assist in measuring sync amplitude. This scale is designed to be used with the 2 line and 2 field sweep rates.

The scale on the right side of the graticule is for measuring depth of modulation. The scale extends from 0% at the 100 IRE line to 100% at sync tip (-40 IRE line).

The boxed area slightly to the right of center at the 100 IRE level is scaled in 2% and 4% increments for precise tilt measurements. This structure is designed to work with an $18 \mu\text{s}$ half-amplitude duration (HAD), 2T bar. The set of solid and short dashed lines to the left of the bar tilt measurement structure is used to measure pulse-to-bar ratio; they are weighted to include K-Factor ratings of 2% and 4%.

Making Measurements. To use the NTSC vertical scale to make line time distortion and pulse-to-bar ratio measurements, set the signal blanking level at the graticule blanking line (0 IRE) and position the leading edge of the Composite Test Signal bar to the ascending arrow (just right of graticule center). Check to see if insertion gain is unity. If it is not, adjust the 1730-Series VAR for exactly 100 IRE of signal amplitude from baseline to the middle of the white bar. Check to see that the negative-going bar transition passes through the descending arrow.

To measure the K-Factor line time distortion, measure the largest deviation of the bar top (tilt or rounding) within the structure. The structure is designed to ignore the first and last $1 \mu\text{s}$ of the bar where short-time distortions (ringing, overshoot, undershoot, etc.) occur. The solid outer box equals a 4% K-Factor, while the dashed line inner box equals a 2% K-Factor. (For signals with a bar

HAD that exceeds $18 \mu\text{s}$, simply measure the bar top in increments by positioning the bar to the left or right from the leading or trailing edge. Note that when the leading or trailing edge is on the appropriate arrow, the first or last $1 \mu\text{s}$ is automatically excluded from the measurement.)

Pulse-to-bar K-Factor measurements are made using the solid and short dashed lines to the left of the line time distortion structure. These lines are scaled according to the following formulas:

$$\frac{1}{(1-4K)} \quad \text{and} \quad \frac{1}{(1+4K)}$$

Where: $K=0.02$ for 2% K-Factor (dashed lines)
 $K=0.04$ for 4% K-Factor (dashed lines)

Calibrated 5X Gain increases resolution to 0.4% and 0.8%.

This scaling is described in detail in CCIR Standard Volume 5, 1966.

Make sure that the center of the bar is at 100 IRE when blanking level is at 0 IRE (use VAR to adjust gain, if necessary). If necessary, use the HORIZONTAL Position control to place the 2T pulse over the measurement area and measure its amplitude. The top of the pulse falling within the dashed lines equals less than 2% K-Factor.

Horizontal Scales for NTSC and PAL Graticules

The Horizontal reference line is the baseline at 0 IRE (NTSC and PAL-M) or 0.3 V (PAL). This timing line is 12 divisions long on NTSC graticules (12.4 divisions for PAL), and takes on different timing intervals depending on the sweep rate selected. In 2 line sweep each major division is $10 \mu\text{s}$, and when magnified (X10), each major division equals $1 \mu\text{s}$. In 1 line sweep each major division is equal to $5 \mu\text{s}$, and when magnified (X25) each major division equals $0.2 \mu\text{s}$. In 2 field sweep the timing scale is of no real value, since this is a monitoring mode; however when 2 field sweep is magnified (X25) the entire vertical (field) interval can be displayed.

PAL Graticule Vertical Scales

The PAL graticule scales are from 0 to 1.2 V on the left side. See Figure 2-17.

The right side has markings at sync tip (-0.3 V), baseline (0 V), and peak white ($+0.7 \text{ V}$). There are 2% and 4% markings at the horizontal center of the graticule on the 0 V line (sync tip level) to assist in measuring sync amplitude. The dashed horizontal line at the top of the graticule is equal to 1.234 V to indicate peak amplitude of 100% color bars.

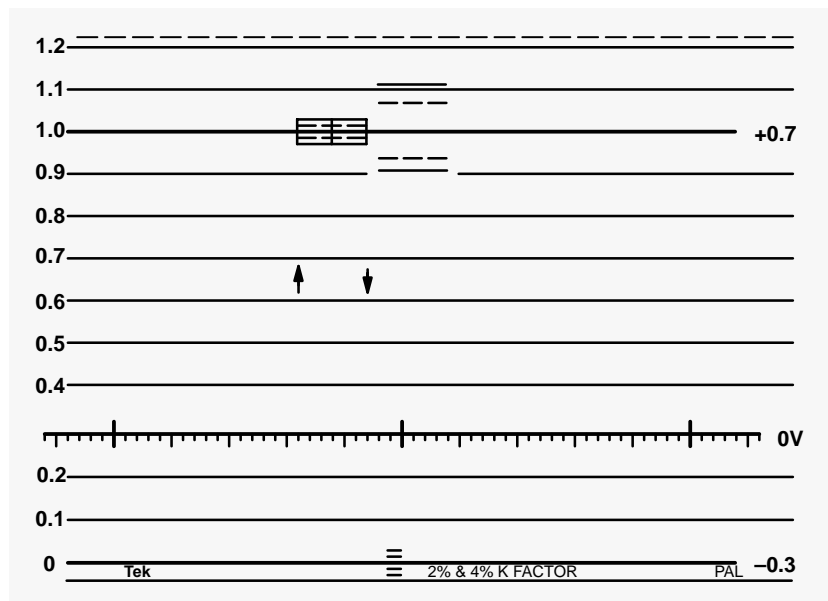

Figure 2-17: PAL graticule.

The boxed area slightly to the left of center at the 1.0 V level is scaled for 2% and 4% K-Factor ratings for precise tilt measurements. This structure is designed to work with an 8 μ s, half-amplitude duration (HAD) bar. The short dashed lines to the right of the bar tilt measurement structure are used to measure pulse-to-bar ratio; they are weighted for 2% and 4% K-Factor ratings.

There are 2% and 4% markings near the horizontal center of the graticule on the 0 V line (sync tip level) to assist in measuring sync amplitude. The dashed horizontal line at the top of the graticule is equal to 1.234 V to indicate peak amplitude of 100% color bars. Between the 0.9 V and 1.1 V lines, there are markings at 20 mV intervals.

Making Measurements. To use the PAL vertical scale for measuring the K-Factor for line time distortion and pulse-to-bar ratio measurements, set the signal blanking level at the graticule blanking line (0.3 V) and position the leading edge of the bar to the ascending arrow, just right of graticule center. Check to see if insertion gain is unity. If it is not, adjust the 1730-Series VAR for exactly 0.7 V of signal amplitude from baseline to middle of the white bar. Check to see that the negative-going bar transition passes through the descending arrow.

To measure the K-Factor for line time distortion, measure the largest deviation of the bar top (tilt or rounding) within the structure. The structure is designed to ignore the first and last 1 μ s of the bar where short-time distortions (ringing, overshoot, undershoot, etc.) occur. The solid outer box equals a 4% K-Factor, while the dashed line inner box equals 2% line time K-Factor. (For signals with a bar half-amplitude duration (HAD) that exceeds 8 μ s, simply measure the bar

top in increments by positioning the bar to the left or right from the leading or trailing edge. Note that when the leading and trailing edge is on the appropriate arrow, the first or last 1 μ s is automatically excluded from the measurement.)

Pulse-to-bar K-Factor measurements are made using the solid and short dashed lines to the right of the line time distortion structure. These lines are scaled to the following formulas:

$$\frac{1}{(1-4K)} \quad \text{and} \quad \frac{1}{(1+4K)}$$

Where: K=0.02 for 2% K-Factor (dashed lines)
 K=0.04 for 4% K-Factor (dashed lines)

Calibrated 5X Gain increases resolution to 0.4% and 0.8%.

This scaling is described in detail in CCIR Standard Volume 5, 1966.

Make sure that the center of the bar is at 100 IRE when blanking level is at 0 IRE (use VAR to adjust gain, if necessary). If necessary, use the HORIZONTAL Position control to place the 2T pulse over the measurement area and measure its amplitude. The top of the pulse falling within the dashed lines equals less than 2% K-Factor.

Dual Graticule Vertical Scales

The PAL vertical scale, from 0 V to 1.2 V, is provided on the left side of the 1735 graticule. See Figure 2-18. The NTSC vertical scale is provided on the right side of the 1735 graticule. It extends from -40 IRE to 120 IRE, in 10-IRE increments. Black level setup is denoted by a dashed line at 7.5 IRE. There are 2-IRE and 4-IRE markings near the horizontal center of the graticule, on the -40 IRE line (sync tip) to assist in measuring sync amplitude. This scale is designed to be used with the 2LINE or 2FLD Sweep rates.

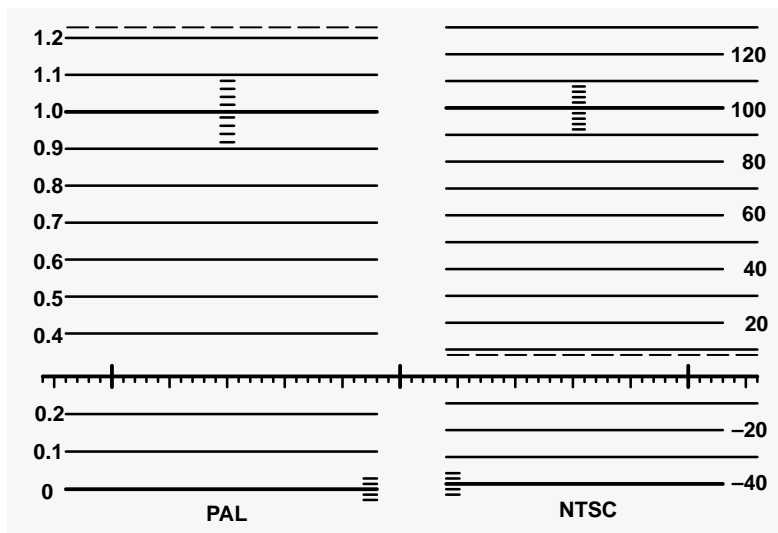

Figure 2-18: Dual standard graticule.

Preset Front-Panel Measurements

The 1730-Series has four front-panel setups stored in internal memory. A TTL low (or ground closure) on one of the PRESET enables (pins 12 through 15 of the REMOTE connector) selects one of these pre-programmed, front-panel setups. Table 2-1 shows the preset front panels that are stored in memory.

When the 1730-Series is used as a direct replacement for the TEKTRONIX 528A Waveform Monitor (which used dc voltage levels as enables), it will be necessary to use a conversion circuit to change these positive voltage levels to apparent ground closures. See Figure 3-3 for a simple conversion circuit.

Table 2-1: Preset Front Panels

Front-Panel Control	Preset 1 (pin 13)	Preset 2 (pin 14)	Preset 3 (pin 15)	Preset 4 (pin 12)
INPUT Channel	A	A	A	A
INPUT Reference	EXT	INT	INT	INT
INPUT Filter	FLAT	FLAT	FLAT	FLAT
VERTICAL Gain (VAR)	off	off	off	off
VERTICAL Gain (X5)	off	off	off	off
VERTICAL DC Restorer	OFF	OFF	SLOW	SLOW
HORIZONTAL Field	FLD 1	ALL	ALL	FLD 1
HORIZONTAL Sweep	2 FLD	2 LINE	1 LINE	2 LINE

Table 2-1: (Cont.) Preset Front Panels

Front-Panel Control	Preset 1 (pin 13)	Preset 2 (pin 14)	Preset 3 (pin 15)	Preset 4 (pin 12)
HORIZONTAL Magnifier	off	off	off	off
LINE SELECT	off	15 LINE	ON	off
LINE SELECT (Line)	---	100	19	---

RGB/YRGB Display

RGB staircase signals, either 3- or 4-step, are input to the 1730-Series through the rear-panel REMOTE connector. A 10 V input will provide a horizontal sweep length between 7.6 and 10.4 major graticule divisions. An adjustment on the Main circuit board (R856) can be used to adjust for offsets in various staircase signals. RGB sweep is enabled by a TTL low, which can be a ground closure applied to pin 2 of the rear-panel 15-pin connector. (There is a connector drawing in Section 3, Installation, of this manual.) The staircase signal is input through pin 1 of the connector.

Field and line rate displays, controlled by front-panel SWEEP settings, are available. These sweep rates can be magnified (2LINE X10 and 2FLD or 1LINE X25). In addition, a low (ground closure) at pin 3, when 2FLD Sweep is selected, provides a 1 Field Sweep.

Remote Sync

Pin 10 of the REMOTE connector is a remote sync input. A 30 or 60 Hz (25 or 50 Hz for PAL) square wave signal with an amplitude of 2 to 5 volts will trigger the 1730-Series 2FLD Sweep. In addition, a 4 V composite sync signal can also be used as a remote sync signal. Pin 4, when pulled low (TTL low or ground) enables the Remote Sync triggering.

90 Hz (NTSC) or 100 Hz (PAL) Trigger

Pin 10 of the REMOTE connector ($\overline{\text{REM SYNC IN}}$) is also used as the input for 90 Hz (100 Hz PAL) triggering associated with D2 VTRs. The internal remote Sync Polarity jumper (A3J635) and 90/100 Hz Trigger Enable jumper (A3J540) will have to be moved to accept this trigger signal. See Section 3 (Installation).

When the internal jumpers have been reset and pin 4 ($\overline{\text{REM SYNC EN}}$) is grounded, the 90 Hz (100 Hz PAL) triggering is enabled. Once the jumpers are enabled and 2FLD SWEEP is selected, a 2 V or greater 90 Hz (100 Hz PAL) square wave, applied to REMOTE connector pin 10 ($\overline{\text{REM SYNC IN}}$), will trigger a 1-field sweep.

Service Safety Summary

Only qualified personnel should perform service procedures. Read this *Service Safety Summary* and the *General Safety Summary* before performing any service procedures.

Do Not Service Alone. Do not perform internal service or adjustments of this product unless another person capable of rendering first aid and resuscitation is present.

Disconnect Power. To avoid electric shock, switch off the instrument power, then disconnect the power cord from the mains power.

Use Caution When Servicing the CRT. To avoid electric shock or injury, use extreme caution when handling the CRT. Only qualified personnel familiar with CRT servicing procedures and precautions should remove or install the CRT.

CRTs retain hazardous voltages for long periods of time after power is turned off. Before attempting any servicing, discharge the CRT by shorting the anode to chassis ground. When discharging the CRT, connect the discharge path to ground and then the anode. Rough handling may cause the CRT to implode. Do not nick or scratch the glass or subject it to undue pressure when removing or installing it. When handling the CRT, wear safety goggles and heavy gloves for protection.

Use Care When Servicing With Power On. Dangerous voltages or currents may exist in this product. Disconnect power, remove battery (if applicable), and disconnect test leads before removing protective panels, soldering, or replacing components.

To avoid electric shock, do not touch exposed connections.

X-Radiation. To avoid x-radiation exposure, do not modify or otherwise alter the high-voltage circuitry or the CRT enclosure. X-ray emissions generated within this product have been sufficiently shielded.

Warning

The following servicing instructions are for use only by qualified personnel. To avoid personnel injury, do not perform any servicing other than that contained in the operating instructions unless you are qualified to do so. Refer to General Safety Summary and Service Safety Summary prior to performing any service.



Installation

Section 3 Installation

This section of the manual provides the information necessary to install the 1730-Series monitor in its operating environment. Information contained here provides electrical and mechanical installation, plus settings for the internal jumpers and descriptions of the available, optional cabinets.

Packaging The shipping carton and pads provide protection for the instrument during transit, they should be retained in case subsequent shipment becomes necessary. Repackaging instructions can be found in Section 6 (Maintenance) of this manual.

Electrical Installation

Power Source This instrument is intended to operate from a single-phase power source with one current-carrying conductor at or near earth-ground (the neutral conductor). Only the Line conductor is fused for over-current protection. Systems that have both current-carrying conductors live with respect to ground (such as phase-to-phase in multiphase systems) are not recommended as power sources.

This section of the manual provides the information necessary to install the 1730-Series monitor in its operating environment. Information contained here provides electrical and mechanical installation, plus settings for the internal jumpers and descriptions of the available, optional cabinets.

Mains Frequency and Voltage Ranges All members of the 1700-Series instrument line operate over a frequency range of 48 to 66 Hz, at any mains voltage between 90 Vac and 250 Vac. These newer versions of the 1730-Series instruments *do not* require any internal changes to select their operating voltage range.

Operating Options

Not all installations are identical. In order to make operation of the 1730-Series Waveform Monitor as flexible as possible there are internal jumpers that can be changed to provide operating flexibility. For example, it is possible to select either the 3-step or 4-step parade to accommodate RGB or YRGB displays. With the exception of the 50-60 Hz jumper, the factory preset position is

indicated by a box printed on the etched circuit board. Table NO TAG details these internal jumper selections. Be sure that all operators are aware of changes, to prevent unnecessary trouble reports, if any of these jumpers are placed in the optional position. See Figure 3-1 for location of the internal plug jumpers.

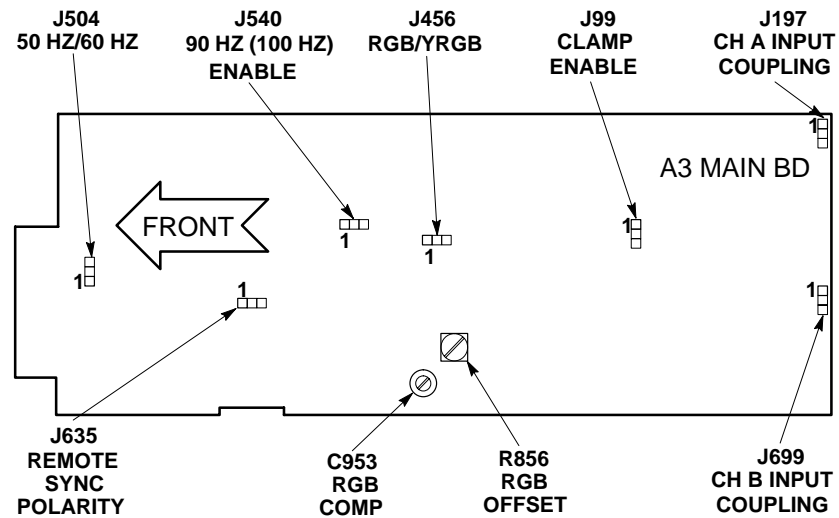

Figure 3-1: Plug jumper locations and RGB compensation adjustments. Pin 1 is denoted by a small numeral 1 next to the plug jumper symbol.

Table 3-1: Internal Jumper Selections

Jumper Number	Name	Position	Purpose
A3J99	Clamp Enable	1-2 2-3	Not used Standard (factory preset)
A3J197	CH-A Input Coupling	1-2 2-3	AC coupled (factory preset) DC coupled
A3J699	CH-B Input Coupling	1-2 2-3	AC coupled (factory preset) DC coupled

Table 3–1: Internal Jumper Selections

Jumper Number	Name	Position	Purpose
A3J456	RGB/YRGB	2-3	RGB, 3-step parade (factory preset)
		1-2	YRGB, 4-step parade
A3J504	50/60 Hz (1735 factory set)	1-2	50 Hz line rate (factory set for 1731)
		2-3	60 Hz line rate (factory set for 1730) ¹
		1-2	Jumper in 1-2 position or removed. ²
A3J540	90 Hz (100 Hz)	1-2	90 or 100 Hz
		2-3	1 Line/1 Field (factory preset)
A3J635	Remote Sync Polarity	1-2	Positive (factory preset)
		2-3	Negative
A3A1 J100	Light Enable	1-2	Lights Enabled (factory preset)
		2-3	Lights Disabled

1. 1731 PAL-M requires A3J504 be in the 2-3 position.

2. Having A3J504 in the 2-3 position inhibits the 1735 standard switching.

REMOTE Connector

The rear-panel REMOTE connector is a 15-pin, D-type connector. It is the Remote Control Interface, the input for RGB signals and Remote Sync.

Remote functions, which provide switching and recalling of stored front-panel setups at a remote location, are enabled by ground closures (TTL lows). Functions with “overbars” indicate an active low state. In addition to the four front-panel RECALL SETUPs that can be called up remotely, there are four additional factory-programmed Presets that can only be called up through the REMOTE connector. Pin assignments for the REMOTE connector are shown in Figure 3-2 and discussed in Table 3–2.

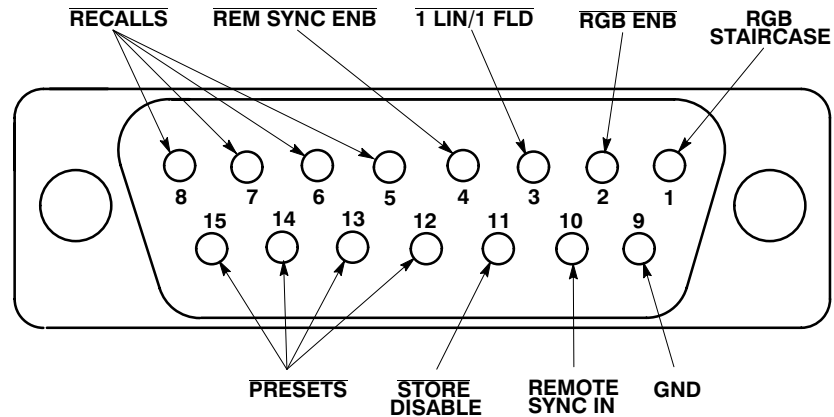

Figure 3-2: REMOTE connector pin functions.

Table 3-2: Remote Connector Pin Assignments and Functions

Pin	Name	Function/Description
1	RGB Staircase	The RGB Staircase input signal controls the internal sweep ramp to offset the Horizontal in time with the RGB PARADE signal.
2	RGB Enable	Low = RGB Enable. Level sensitive, allows the instrument to process the RGB staircase input.
3	1 LIN, 1 FLD	1 LIN, 1 FLD selection available when A3W922 is installed, A3W709 is not installed, and A3J540 is on pins 2 & 3 (90 Hz Trig not enabled). Low = Enable 1 LINE or 1 FIELD. 1 LINE if line rate sweep is selected, or 1 FIELD if field-rate sweep is selected.
	PAL	PAL available when A3W709 is installed, A3W922 is not installed, and A3J540 is on pins 2 & 3 (90 Hz Trig not enabled). Low = Enable.
	90 Hz	90 Hz triggering available when A3W922 is installed, A3W709 is not installed, and A3J540 on pins 1 & 2 (90 Hz Trig enabled).
4	REMOTE SYNC EN or 90-100 HZ TRIG EN	Low = Enable Remote Sync. Enables instrument for the Remote Sync input signal or 90/100 Hz Sync input signal on pin 10.

Table 3-2: (Cont.) Remote Connector Pin Assignments and Functions

Pin	Name	Function/Description
5	RECALL 2	Recalls the named user defined front-panel settings from non-volatile memory, when pulled low (grounded). If more than one pin (5, 6, 7, or 8) is low, the first pin that went low is the one recalled.
6	RECALL 3	
7	RECALL 1	
8	RECALL 4	
9	GROUND	Instrument ground for remote control.
10	REMOTE SYNC INPUT	Pin 10 can be used to input Remote Sync or 90 Hz (100 Hz PAL) Sync. Remote Sync is usually a field-rate square wave. It is routed around the Sync Stripper and directly to the Sweep Gating circuitry.
	90 (100) HZ INPUT	90 HZ Sync input signal is a TTL level square wave.
11	STORE	Low = Store disabled. When this line is low, the front-panel STORE button is disabled. Prevents unauthorized changes to the user-defined recalls.
12	FRONT-PANEL PRESET 4	Remotely selects the factory preset front-panel settings from memory, when pulled low (grounded). If more than one pin (12, 13, 14, or 15) is low, the first pin that went low is the one recalled. (Setting is defined in Section 2, "Preset Front-panel Measurements.")
13	FRONT-PANEL PRESET 1	
14	FRONT-PANEL PRESET 2	
15	FRONT-PANEL PRESET 3	

90 Hz (100 Hz) D-2 Trigger

This function allows the 1730-Series to be triggered by a 2 V, 90 Hz (NTSC) or 100 Hz (PAL) square-wave output from a D-2 VTR. The display is a single field rate sweep selected when the front-panel SWEEP is set to 2FLD. 90 Hz (100 Hz) sweep triggering disables the 1730-Series Remote Sync Input.

The 90 Hz (100 Hz) sweep trigger, when enabled, is input through pin 10 of the rear-panel REMOTE connector. To enable this option (and disable Remote Sync) reposition two internal jumpers:

A3J540 is moved to the 90 Hz (100 Hz) position (1-2).

A3J635 is moved to the Negative Sync Polarity position (2-3).

In addition to resetting the jumpers, a TTL low (ground closure) on the REMOTE connector pin 4 is required to enable this trigger mode.

RGB/YRGB Parade Display

A TTL low level (ground) on pin 2 of the REMOTE connector enables the shortened RGB/YRGB sweep. A 10-volt square-wave input to pin 1 provides approximately 9 divisions of sweep. This sweep can be either 1 line or 1 field depending on front-panel switch setting. The displayed signal is the front-panel selected CH A or CH B input.

When the 1730-Series Waveform Monitor is substituted for a TEKTRONIX 528 or 528A Waveform Monitor, in some applications the +28 V enable signal used by the 528 must be converted to ground closure (0 Vdc). This conversion requires only a few common parts, as shown in Figure 3-3.

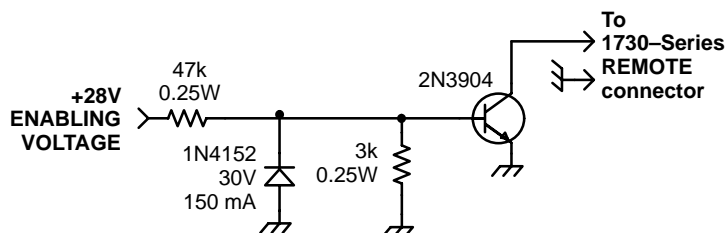

Figure 3-3: Common parts used to convert from +28 Vdc enable to ground closure.

RGB Offset and Compensation — Television cameras vary in output dc level; R856 is provided to compensate for this variation in dc level. See Figure 3-1.

C953 is the input compensation that matches the Staircase Amplifier input time constant to the camera output time constant. See Figure 3-1.

Each time the camera input to the 1730-Series is changed the RGB Offset and input time constant will probably need to be reset. The following procedure provides a simple means to make these adjustments.

Procedure for setting RGB Offset

1. Display any standard television waveform. Do not enable the rear-panel REMOTE connector RGB Enable.
2. Use the 1730-Series HORIZONTAL Position control to align the display with the graticule.
3. Ground the REMOTE connector RGB Enable (pin 2) and apply the camera staircase output to the RGB Staircase input (pin 1).
4. Apply the camera video output to the 1730-Series INPUT (CH-A or CH-B) and select that input with the front-panel INPUT selector.
5. **ADJUST** — R856 (see Figure 3-1 for location) to center the RGB signal on the graticule.
6. **ADJUST** — C953 for the best looking display.

AUXILIARY Connector

The rear-panel AUXILIARY connector is a 9-pin, D-type connector. It is used to control the display on a companion 1720-Series Vectorscope. Line and Field selection information is provided to the Vectorscope over the bus that is contained in this interface. Figure 3-4 and Table 3-3 show the AUXILIARY connector pin assignments.

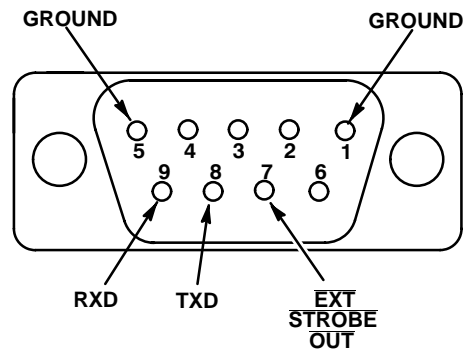

Figure 3-4: AUXILIARY connector pin functions.

Table 3-3: Auxiliary Control Pin Assignments

Pin	Function
2-3-4-6	No Connection.
1-5	Ground.
7	External Strobe Out for Line Select blanking output.
8	TXD (Transmit Data) 1730-Series to 1720-Series communication line.
9	RXD (Receive Data) 1720-Series to 1730-Series communication line.

Mechanical Installation

Cabinets All qualification testing for the 1730-Series was performed in a 1700F00 cabinet. To guarantee compliance with specifications, the instrument should be operated in a cabinet. The plain cabinet, 1700F00, is shown in Figure 3-5.

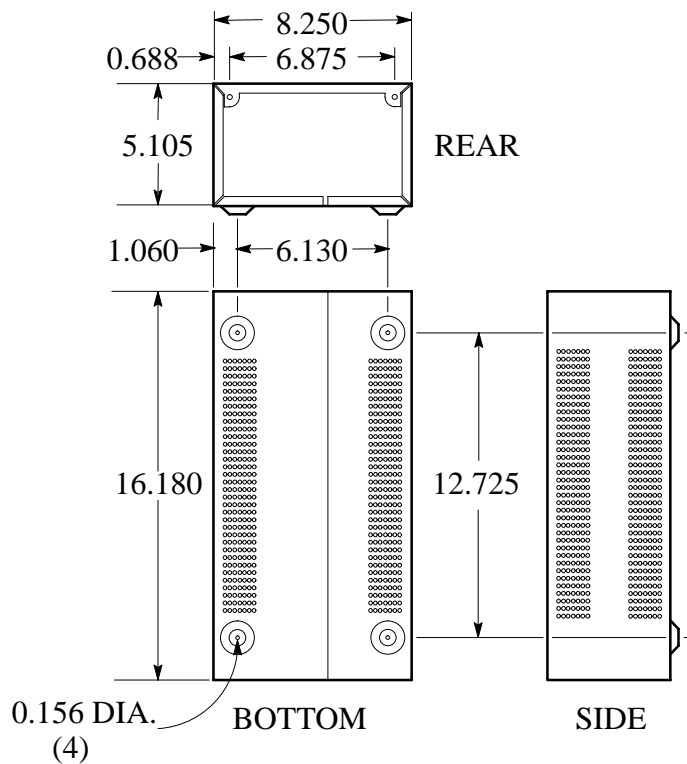

Figure 3-5: Dimensions of the 1700F00 plain cabinet.

The portable cabinet, 1700F02, is shown in Figure 3-6. The 1700F02 has a handle, four feet, a flip-up stand, and is compatible with the TEKTRONIX BP1 battery pack that can be used for a dc power source. The hole sizes and spacing are different from those of the 1700F00.

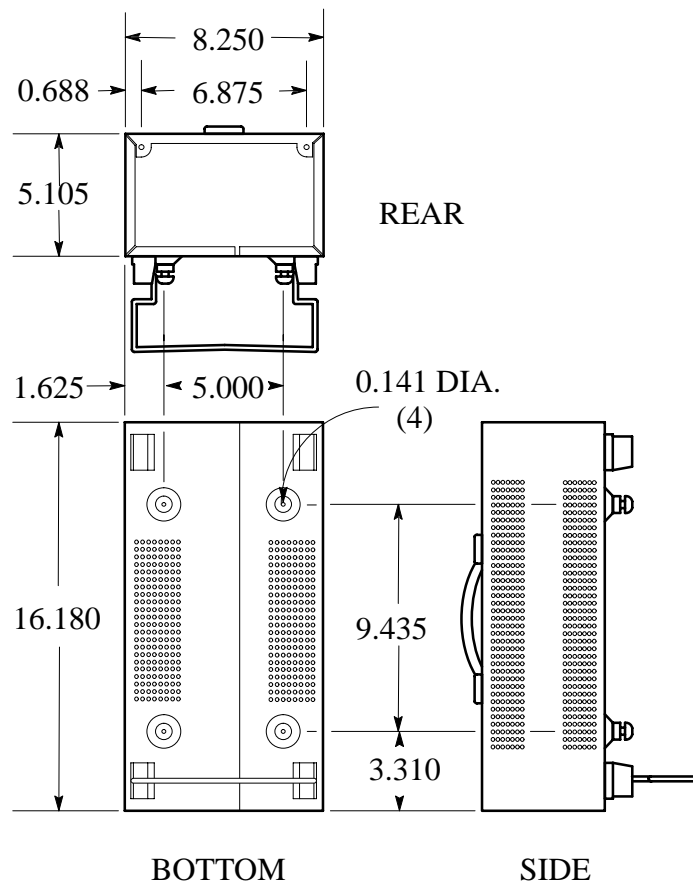

Figure 3-6: 1700F02 portable cabinet.

All of the 1700-Series metal cabinets, which are available from Tektronix as Optional Accessories, provide the proper electrical environment for the instrument. They supply adequate shielding, minimize handling damage, and reduce dust accumulation within the instrument.

Cabinetizing



Do not attempt to carry a cabinetized instrument without installing the mounting screws. Without the mounting screws there is nothing to hold the instrument in the cabinet if it is tipped forward.

The instrument is secured to the cabinet by two 6-32 Pozidrive® screws, located in the upper corners of the rear panel. See Figure 3-7.

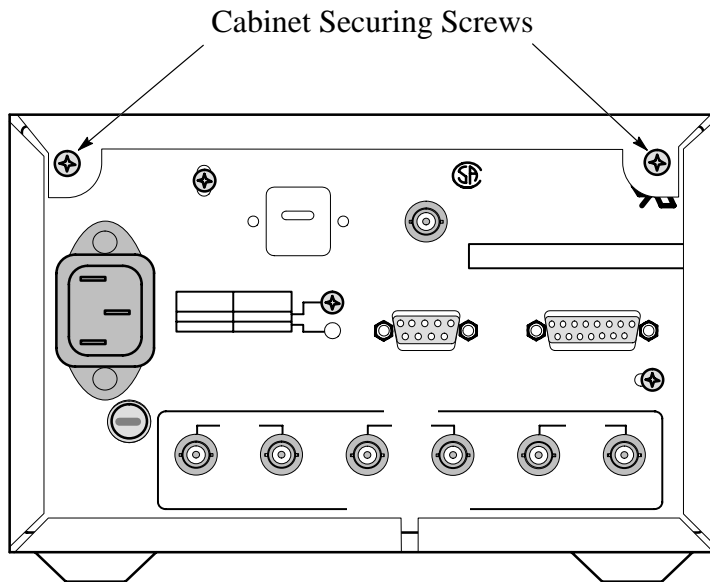

Figure 3-7: Rear view of the instrument, shown in the cabinet, with the securing screws identified.

Rack Adapter

The optional 1700F05 side-by-side rack adapter, shown in Figure 3-8, consists of two attached cabinets. It can be used to mount the 1730-Series and another half-rack width instrument in a standard 19-inch rack.

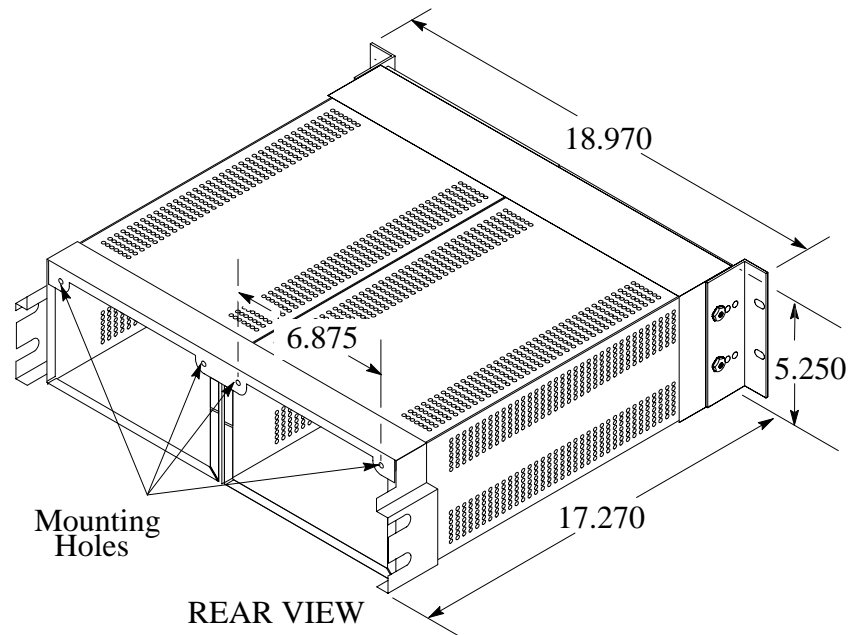

Figure 3-8: The 1700F05 side-by-side rack adapter.

The rack adapter is adjustable, so the 1730-Series can be more closely aligned with other equipment in the rack. See Figure 3-8.

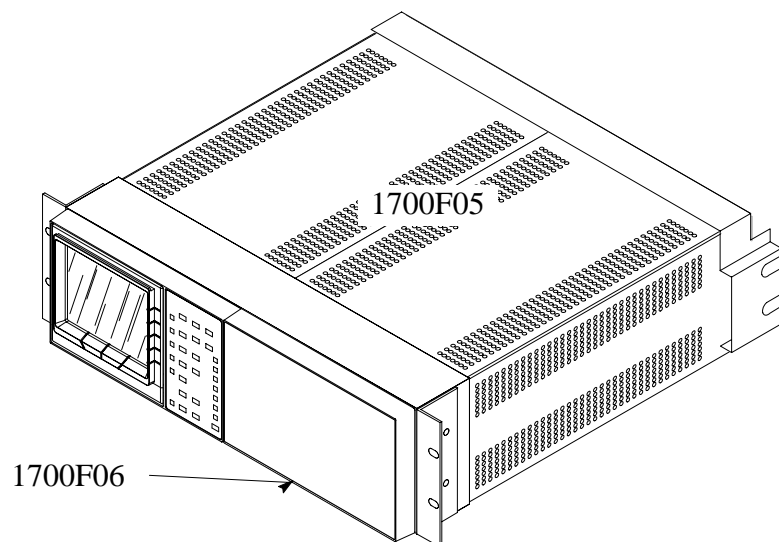

Figure 3-9: A 1700-Series instrument mounted in a 1700F05 cabinet with a blank front panel (1700F06) covering the unused side of the cabinet.

If only one section of the rack adapter is used, a 1700F06 Blank Panel can be inserted in the unused section. See Figure 3-9. The rack adapter and panel are available through your local Tektronix field office or representative.

In addition to being able to fill the unused side of the side-by-side rack mount cabinet (1700F05) with a blank front panel, an accessory drawer (1700F07) can be installed in the blank side of the cabinet. See Figure 3-10.

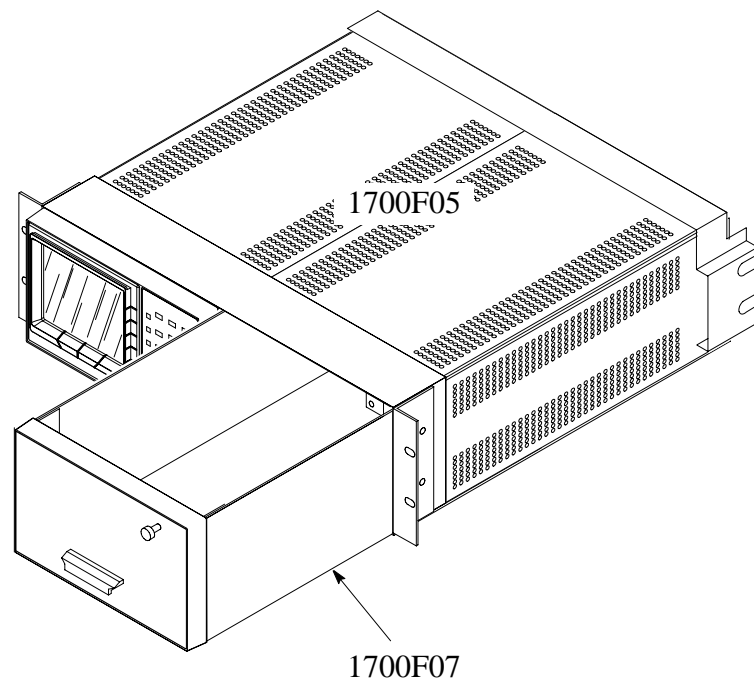

Figure 3-10: A 1700F05 side-by-side rack mounting cabinet with an instrument and a 1700F07 utility drawer.

Custom Installation

For applications such as consoles, shown in Figure 3-11, the instrument can be mounted with front molding flush or protruding from the console. In both cases, allow approximately 3 inches of rear clearance for bnc and power-cord connections.

To mount the 1730-Series safely, attach it to a shelf strong enough to hold its weight. Install the mounting screws through the four 0.156-inch diameter holes in the bottom of the 1700F00 cabinet. See Figure 3-11.

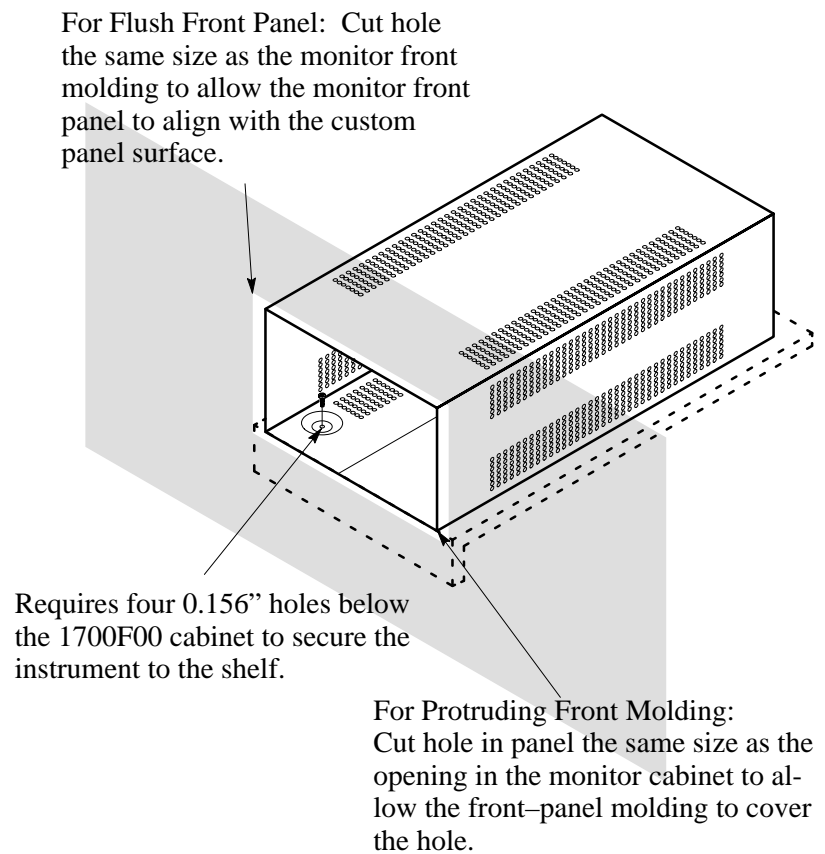

Figure 3-11: Considerations for custom installation of an instrument.



Theory of Operation

Section 4

Theory of Operation

The material in this section is subdivided into a general description (which is supported by the main block diagram and simplified block diagrams) and detailed circuit descriptions that use the schematic diagrams as illustrations. A thorough understanding of the instrument starts with knowing how the major circuit blocks fit together, which is then followed by an understanding of the individual circuit's functions. These discussions of the 1730-Series Waveform Monitor begin with a brief, fundamental overview, then proceed on to the block diagram, and then go into individual circuit descriptions.

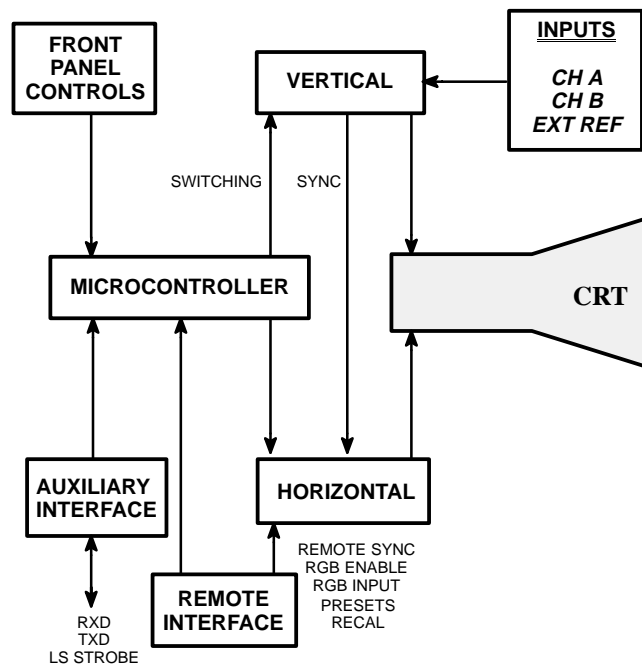

Figure 4-1: Simplified representation of the 1730-Series Waveform Monitor.

Overview

The 1730-Series is a specialized oscilloscope, designed to monitor and measure television baseband signals. See Figure 4-1. Signals input through either of the rear-panel 75Ω bridging loop-through inputs are synchronously displayed on a CRT. In addition, an alpha-numeric line and field readout is provided on the CRT for use with the LINE SELECT mode of operation.

Front-panel mode switching is accomplished by a series of push-button switches whose status is being constantly polled by a Microprocessor. In turn, the Microprocessor controls switching functions and circuit gains so that the instrument can perform as a monitor or be used to make specific measurements. The Microprocessor is an 8051 type.

The Low Voltage Power Supply is a high-efficiency switching type. The High Voltage Power Supply provides 13 kV acceleration potential.

Block Diagram

The Block Diagram for the 1730-Series Waveform Monitor is located on a foldout in Section 9 of this manual. The following functional description uses the diagram as its illustration. The numbers on the circuit blocks correspond to the schematic diagram where that circuit block is detailed.

Circuit Blocks

Vertical — Color-encoded video signals are input through the bridging Channel A and Channel B inputs. The input amplifiers are shunted by sample-and-hold-type clamps, that are timed by a Back Porch Sample from the Back Porch Generator. This clamped signal, prior to any filtering, is also the rear-panel Picture Monitor Output. In LINE SELECT modes, a strobe, that acts as a bright-up pulse, is added to the Picture Monitor Output to identify the selected line (or block of lines in 15 Line). Switching at the output of the amplifiers provides for display of either input signal or a combination of both in all sweep modes. In the combination mode, the Channel A signal is displayed on the left of the CRT with the Channel B following.

Front-panel switching can select a Flat (unfiltered), a Low Pass, or a Chroma filtered signal for display. The low pass filtered signal can be displayed with a Flat (unfiltered signal) as part of the dual filter mode. In dual filter mode, the low pass filtered signal is displayed to the left with the unfiltered (flat) signal following. When the calibrator signal is selected (from the front-panel switching), a 1 volt, 100 kHz signal is applied to the input of the Gain Cell instead of input video. The calibrator signal is used to set up both Vertical Gain (Volts Full Scale) or Horizontal Gain (Sweep rate) from a common, self-contained source.

Signal amplitude can be adjusted at the Gain Cell using either the front-panel V GAIN or VARIABLE gain control. The output signal from the Gain Cell drives another clamped amplifier. This second clamped amplifier has a loop-compensated sample-and-hold circuit to provide the fast clamping required for the Fast DC Restorer. Clamping, as with the first clamp, occurs at back porch time.

The Vertical Positioning voltage, along with the conditioned video signal, is input to a Switchable Gain Amplifier, to provide X5 vertical magnification. Both amplifier gain and positioning range can be increased by a factor of 5 when

X5 Gain is selected at the front panel. The limiter stage that follows prevents overdriving of the Output Amplifier.

The conditioned video signal and the Y component of the Readout (from the Microcontroller) are input to the Vertical Output Amplifier to match impedances and normalize gain (approximately 40 V for 8 cm of vertical deflection) in order to voltage drive the CRT vertical deflection plates.

Horizontal — Composite video from either internal (Channel A or B) or external reference has all active video stripped away by the Sync Stripper to leave only sync to output a sweep trigger. Remote sync, which bypasses the Sync Stripper, triggers the sweep directly when enabled. Remote sync, which is input through the REMOTE connector, requires an external enable.

A jumper determines the polarity of the remote sync for internal triggering: Negative provides line rate triggering off a negative edge and field rate triggering off a positive edge. Positive provides line rate triggering off a positive edge and field rate triggering off a negative edge.

90 Hz (100 Hz for 1731) triggering, for D2-type video recorders, is also input through the REMOTE connector. The 90 Hz triggering uses the Remote Sync Input, with the internal polarity jumper set to negative sync polarity, and the enabling jumper in the enabled position.

The output of the Sync Stripper (or remote sync) drives the Back Porch Generator, Vertical Sync Recognition, and Horizontal AFC. Outputs from the Vertical Sync Recognition and Horizontal AFC are used by the Field ID and Trigger Select to trigger the Sweep Generator. If Calibrator is selected, the Cal Drive signal from the Microcontroller provides the triggering signal.

The Horizontal AFC output, in conjunction with the Microcontroller, drives Line Select, which outputs a pulse that:

1. Drives the Z-Axis Control to unblank the CRT at selected line(s).
2. Provides a bright-up strobe at the selected line(s) for 2 Field Sweep.
3. Provides the Picture Monitor Output bright-up strobe.
4. Generates the Auxiliary Blanking strobe that is used by a companion 1720-Series for line select.

The ramp signal, output by the Sweep Generator, drives the Mag Amplifier, which provides three gain ranges, X1 (un-magnified Sweep), X10 (1 μ s/div. in 2 Line Sweep), and X25 (to display the full vertical interval in 2 Field Sweep, while providing 0.2 μ s/div. sweep rate in 1 Line Sweep). The Horizontal Positioning offset voltage is input to the Magnifier Amplifier to ensure sufficient range to position any part of the display onto the graticule.

When the RGB Parade display is enabled, the sweep is shortened and offset by the RGB Staircase input signal, which produces three short ramps that are displayed (in sequence) as a normal length sweep.

The output of the Mag Amplifier and the X component of the Readout (from the Microcontroller) drive the Horizontal Output Amplifier, which matches impedances and normalizes gain (approximately 100 V for a 10 cm sweep length) in order to voltage drive the CRT horizontal deflection plates.

CRT, Unblanking, and High Voltage

The blanking signal (from Line Select) and the Intensity and Readout voltages are used by the Z-Axis Control to generate an unblanking signal for the CRT during sweep time. When the sweep is magnified, the off-screen portion of the sweep is blanked to increase the on-off contrast ratio. The Focus Amplifier, which is controlled by the front-panel FOCUS control, provides a voltage to the CRT focus ring.

Trace Rotation provides compensation for the magnetic field surrounding the CRT. The CRT is of the Post Acceleration type, which requires a relatively high potential difference between the cathode and post anode. The boost in 2nd anode voltage is provided by an encapsulated 4X Multiplier. Trace Rotation provides compensation for the magnetic field surrounding the CRT.

Vertical Input Diagram 1

The video signal is input to the waveform monitor through amplifiers that can be clamped at back porch time. Once buffered by the input amplifiers, whose gain is -1 , a Channel Switch selects the input to be filtered, drive the picture monitor output, serve as the internal sync source, and eventually be displayed on the CRT.

When an external reference (sync) source is used, the composite signal is input through an ac-coupled amplifier, which also has a gain of -1 . Selection of the sync source is accomplished by a switch that is made up of a common base pair and switching diodes. A clamped sync stripper is used to remove active video information and regenerate a composite sync signal for use by time related monitor circuits.

An accurate 100 kHz waveform from the Microcontroller is amplified and its amplitude set and controlled by the Calibrator. Calibrator output is enabled and output through the vertical amplifier low pass filter. The calibrator enable is also generated by the Microprocessor.

Input Amplifiers

The rear-panel Channel A and B inputs are high-impedance bridging loop-through inputs compensated for use in 75Ω systems. Each amplifier has its own DC Restorer that is controlled by the front-panel restorer switch. Restorers are either both on or off; the $\overline{\text{ONDCR}}$ pulse enables (disables) both U395C (pins 10 & 11) and U395D (pins 14 & 15). When U395C and D close they couple the back porch sample dc level, from the input amplifier output, to the amplifier inputs. See Timing (Diagram 3) for more information about the generation of the BACKPORCH signal.

Because the Channel A and Channel B Input Amplifiers are identical, circuit numbers for the Channel A Amplifier are used to simplify the remainder of this discussion.

The Input Amplifiers are inverting feedback operational amplifiers with a gain of -1 . The input resistor (R_i) is R196 and the feedback resistor (R_f) is R198. A plug and jumper is provided to select input coupling. J197 is factory set to the 1-2 position for ac coupling; it can however, be moved to the 2-3 position to provide dc coupling by bypassing C197, the ac-coupling capacitor.

The DC Restorer is a feedback sample-and-hold circuit. Sampling occurs when U395A (pins 2 & 3) close at back porch time. When the switch closes, the hold cap (C398) charges up to the dc level of the amplifier output. If $\overline{\text{ONDCR}}$, from the Microprocessor (Diagram 5) is present U395D (pins 14 & 15) closes and the loop-compensated Buffer Amplifier (U495A) drives the Input Amplifier input summing junction through R197. The time constant of the restorer does not attenuate 50/60 Hz hum by more than 10%. The choice of fast or slow dc restorer time constant is accomplished loop compensating the 2nd DC Restorer shown on Diagram 2.

Channel Switch

The Input Amplifier output signals drive the channel switch, U492, through pins 2 & 3. The signal selection is determined by the level of the $\overline{\text{CH-B}}$ signal at U492 (pin 10). When $\overline{\text{CH-B}}$ is low, CH-B is selected; when it's high, CH-A is selected. The Channel Switch output (pin 6) drives a current mirror with three current sources.

One current source, through Q793, drives the rear-panel Picture Monitor Output Amplifier (SIG 2). C694 is the response adjustment that compensates the amplifier to match the 75Ω system input impedance. Q792 is the current source for the internal sync signal and Q791 is the current source for the remainder of the vertical. With a 1 V input signal there will be 1.11 mA of signal current flowing through R392 (or R393) into the channel switch. This signal current is available to drive the vertical through Q791 and the PIX MON OUT through Q793.

Only 0.5 mA of signal current is available to drive the sync stripper through Q792. Its emitter resistor, R694, is twice the resistance of R792 and R693, the emitter resistance for Q790 and Q793.

External Sync Input and Source Switch

The external sync signal from the rear-panel EXT REF loop-through is buffered by an operational amplifier consisting of U795A and B. It has a gain of -1 , which is determined by the combination of input resistor (R_i) R997 and feedback resistor (R_f) R898. The operational amplifier output drives Q798, which is one current source for the Source Switch (U795D).

The internal sync current source, for the other side of the common emitter Source Switch (U795D), is Q792. It provides signal current through pin 5 of U795D which also forward biases CR696 when the switching signal ($\overline{\text{EXT}}$) is high. CR698 keeps CR696 from conducting when external sync input is selected.

When external sync is selected, $\overline{\text{EXT}}$ (from the Microprocessor Diagram 5) goes low, turning on U795 (pins 1, 2, & 3) so that signal current from Q798 (the external sync current source) forward biases CR697. The 0.5 mA of signal current from Q798 (external) or Q792 (internal) drives into a common base stage, Q799, which develops a 1 V video signal across R797.

Sync Stripper

The Sync Stripper removes the active video portions of the signal to generate the sync required for timing signals. The circuit detects the sync tip, stretches it (amplifies that portion of the signal), and generates a clean sync signal. The circuit responds well to pulses up to 1 MHz, then rolls off to eliminate any effect from subcarrier or high frequency noise at the sync level.

The Sync Stripper circuit consist of a two-stage amplifier and a clamp (or dc restorer). Figure 4-2 shows a simplified schematic of the circuit. Both amplifier stages feed back sync level information to the clamp.

The first stage of the amplifier inverts the video signal and clips it near the sync tip. (The bandwidth of the Sync Stripper keeps the circuit from clamping to high frequency components of the video signal.) This operational amplifier stage is made up of Q992 and U892C. The gain setting resistors R993 (R_i) and R992 (R_f) let the amplifier provide high gain to the sync tip portion of the signal, but clip any signal components slightly above the sync level.

During sync time, the clamp circuit maintains the output of the first amplifier stage at about +5 V, which is fed back to the clamp circuit, through CR990, to maintain the proper level.

During non-sync times (active video), CR988 and CR989 are both on to shunt U892C and greatly reduce the gain. Shunting the active video limits the saturation of U892C, which allows it to respond quickly to the next sync transition.

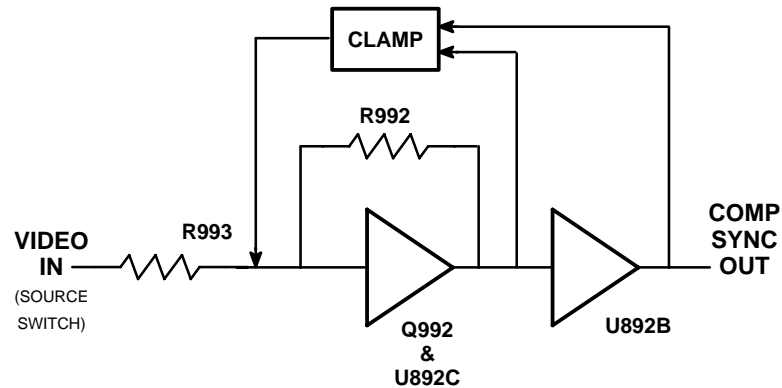

Figure 4-2: Simplified block diagram of the Sync Stripper.

An inverting amplifier, U892B, is the second amplifier stage. It provides negative-going sync and cleans up any remaining noise or active video on the signal. Output of the second stage is also fed to the clamp.

The clamp circuit is formed around U892E and U892A. U892E and CR990 form a current switch. When the first stage output level is at sync tip, current flows through U892E, which charges C887. At the same time U892B pulls down on CR887 to provide a discharge path for C887. The result of these opposing actions is to establish an equilibrium voltage on C887. At the end of sync time U892C saturates and pulls down on CR990 to shut off U892E.

Filter Selection

The three filters are driven from current source Q791 through one of the analog switch sections of U786. Only one switch section will be closed at a time, as dictated by its enable, from the Microprocessor (Diagram 5) going low. Chrominance filters are clamped to ground when low pass filtering or flat is selected. In this condition Q777 and Q776 are turned on clamping the chrominance filter outputs to ground.

When the chrominance filter is turned on an additional bias current for the ac-coupled filters (3.58 and 4.43 MHz) is required. It is supplied by pulling the emitters of either CR671 or CR670 low with the Microprocessor-generated enable signal, which turns on Q775 to saturate Q774. When Q774 saturates its collector goes to +11.8 V. Signal current from the enabled filter drives the emitter of a common base amplifier input to the Gain Cell (Diagram 2). At a 0 Vdc level 2 mA of bias current is added to 1 mA of signal current that drives the input of the Gain Cell.

When dual filter or dual input display is selected a blanking signal is required to mask any potential switching transit that might occur. Whenever CH B or FLAT goes active an RC circuit consisting of C94 (CH B) or C871 (FLAT) and R878

and R885 generates a pulse through Q764. Q765 inverts the blanking pulse, which is input to the blanking circuitry on Diagram 4.

Calibrator The Calibrator is a common base amplifier, Q587, that is driven by a 100 kHz square wave from the Microprocessor (Diagram 5). It is switched at the 100 kHz rate. The gain is set by adjusting R689, the Cal Amp. The emitter current drives the Low Pass filter (which is at least 30 dB down at 3.58 to 4.43 MHz) through an analog switch, U585C, which is activated by the Microprocessor-generated CAL.

VERTICAL OUTPUT Diagram 2

The filtered video signal drives the signal input of a gain cell whose gain is controlled by the front-panel V CAL and, when selected, VAR VERTICAL GAIN. The gain normalized video signal drives an amplifier that can be clamped at back porch time with either a fast or slow time constant clamp, which is also selected by front-panel selection.

The Switchable Gain Amplifier input is the dc level shifted (Vertical Position) output of the Gain Cell Amplifier. Amplifier gain is switchable between X1 and X5 as selected by the front-panel X5 VERTICAL GAIN. Amplifier output drives a Bridge Limiter that prevents the Vertical Output Amplifier from being overdriven.

The Vertical Output Amplifier is driven by the processed video signal or, in Line Select, by an appropriate combination of video and the Y-Axis portion of the readout signal. The output amplifier has enough gain to drive the CRT deflection plates, while providing the compensation for the deflection plate capacitance.

The picture monitor out signal from the Channel Switch (Diagram 1) is amplified and compensated to drive a 75 Ω load by the Pix Mon Out amplifier. In addition, a bright-up pulse is added to the picture monitor output signal.

Gain Cell Q684 drives the Gain Cell. It is a low impedance (to terminate the filters) common base amplifier. The signal voltage off collector is approximately 0.5 V.

The Gain Cell (U578) is driven differentially; pin 1 is the signal input with a -3.0 Vdc level plus the signal voltage. R675 determines the maximum gain of the Gain Cell. The amount of gain is controlled by varying the difference between the bases of the two transistor pairs controlling the signal current flowing out of pin 6 or pin 12. The front-panel V CAL control, R700, sets an input dc level on pin 10 of the Gain Cell. When Variable Gain is selected, the

front-panel GAIN control alters the dc level on pin 10 through an analog switch, U585B. The switch is closed only when Variable is selected.

The current flowing out of pin 6 drives the Gain Cell Amplifier, while the current flowing out of pin 12 drives into a collector load, R480.

Gain Cell Amplifier

The Gain Cell Amplifier is a clamped inverting operational amplifier driving both the Switchable Gain Amplifier and the 2nd DC Restorer. It consists of Q673, Q674, and Q669, with Q669, an emitter follower, operating as the output stage. Amplifier gain is approximately 4.

2nd DC Restorer

The DC Restorer clamps the output level of the Gain Cell Amplifier to the dc level occurring at back porch time. DC Restorer drive is coupled through R474 into an analog switch (U277B) that is activated by the $\overline{\text{BACKPORCH}}$ signal. U277B closes during back porch time to charge the hold cap, C484. The Error Amplifier (U488) drives a current summing point at the input of the Gain Cell Amplifier through U585D. For slow restorer, R484 is in the loop compensation. However; for fast dc restorer, R484 is shorted to ground through U277C to speed up the loop time constant. The enable signal for U277C is from the Microprocessor on Diagram 5 and is only present when Fast DC Restorer is selected.

Switchable Gain Amplifier

The Switchable Gain Amplifier consists of Q476, Q477, and Q478, with Q469 as the switching element. When the base of Q469 is pulled low through R472, amplifier gain is -1 . R_i is R475 and R_f is the sum of R367 and R368. When its base is high, Q469 saturates and grounds the collector end of R470 to put an attenuator in the feedback path and increase gain by a factor of five. The output, at the collector of Q476, drives a bridge limiter circuit comprised of CR280 and CR380. See Figure 4-3 for a simplified diagram of the limiter.

The purpose of the limiter is to prevent the Vertical Output Amplifier from being over driven. The bridge limiter circuit, encompassing CR280 and CR380, is quiescently balanced (equal current through all arms) with no V_{in} . When there is a signal voltage (V_{in}) applied to the bridge (CR1-CR2), the output signal voltage (CR3-CR4) is approximately equal to the input. When V_{in} moves away from the quiescent state, the current in the bridge arms becomes unbalanced.

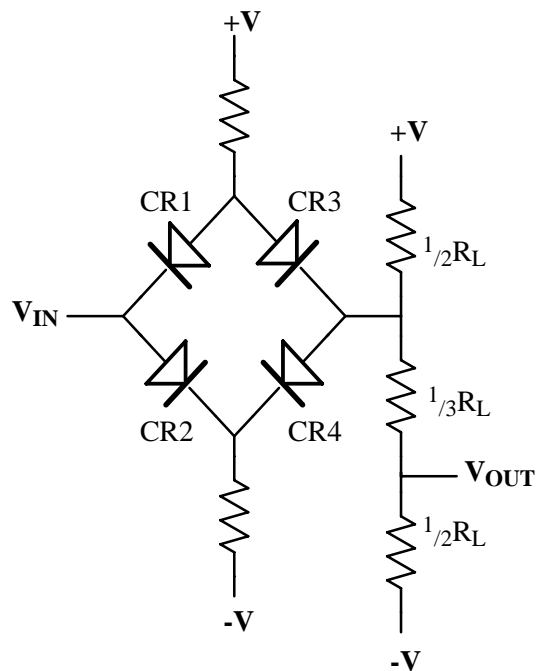

Figure 4-3: Simplified illustration of the Bridge limiter circuit.

When the bridge unbalances the current through the diodes changes, with more current flowing into the load through either CR3 (positive excursion) or CR4 (negative excursion), which turns the diode on harder. At the same time current flowing through the complementary input diode CR1 (positive excursion) or CR2 (negative excursion) is reduced and the diode starts to turn it off. If the change in V_{in} is large enough, the output diode takes all of the current (which turns off the input diode) and disconnects the input from the output.

The bridge load, R378, R377, and R374, is also a voltage divider that sets the input dc level for the Vertical Output Amplifier at approximately -2 V.

Vertical Output Amplifier

The level shifted input signal drives the base of Q383 during active video signal time. The active video signal is disconnected while Line Select readout is displayed (U277D). Q383 is driven by the Y-Axis signal, through U277A, when the vertical component of the readout is displayed. The Y-Axis signal is enabled through the switch when \overline{ROEN} goes low.

The combination of Q382 and Q383 forms a shunt-feedback amplifier. Q382 amplifies and inverts the collector current flowing in Q383 to provide most of the signal current through R485. Because the current across Q382 is nearly constant the input-signal voltage is applied directly across its emitter resistor, R485, with very little distortion. Negative feedback is employed to improve

linearity and reduce the thermal distortions introduced by Q383. In addition, negative feedback increases the input impedance. A series compensation network consisting of R384 and C384 provides improved bandwidth and stability.

The combination of Q385 and Q387 form a shunt-feedback amplifier, identical to Q383 and Q382. The signal current for this amplifier is input through R485. Signal current through Q387 is equal in value and opposite in phase to the current change in Q382. The Limit Center, R489, balances the bias current flowing in Q382 and Q387. R387 and C387 form another series compensation to improve bandwidth and stability. R486 and C389 provide high-frequency peaking to improve the flat response; R385 and C385 improve low-frequency transient response.

Q280 and Q289 are common-base stages that couple the complementary signal currents to the non-inductive CRT load resistors, R184 and R186. The resulting signal voltages drive the CRT vertical deflection plates. R183 and R187 shunt the load resistors to provide the proper load resistance for the high-bandwidth output signal. L180 and L190 are adjustable shunt-peaking coils to increase the vertical bandwidth and allow precise adjustment of flat response.

Pix Monitor

The Picture Monitor Output Amplifier consists of U978 and Q877. The amplifier is driven from pin 2 of U978D by the SIG 2 input from Diagram 1. The output, that drives a 75Ω load, is the emitter of U978A (pin 7). R883 and R884, on the amplifier input, develop the signal voltage $0.554V$ ($1\text{ mA} * 554\Omega$).

The overall gain for this non-inverting amplifier is set by feedback divider resistors R975 and R876. The signal amplitude at the emitter of U978A is $2V$ ($0.554 * (1+3570/1400)$). Q973 adds an offset to the video, for LINE SELECT operation, that provides the bright-up (or strobe) pulse. The amount of the offset is set by the value of R870.

Timing Diagram 3

Composite sync from the Sync Separator (Diagram 1) is used to time the Horizontal and Vertical Sync Generators. Outputs from these generators are used to develop line and field rate signals that are used to display selected lines or fields of information. The Clamp Pulses used to time the vertical amplifier DC Restorers are generated by a Back Porch Generator driven by the Horizontal Sync Generator.

The input Staircase for the RGB/YRGB parade display is input to an operational amplifier through the rear-panel REMOTE connector. The compensatable (dc level and transient response) RGB Amplifier is enabled (RGB ENABLE) by a TTL low.

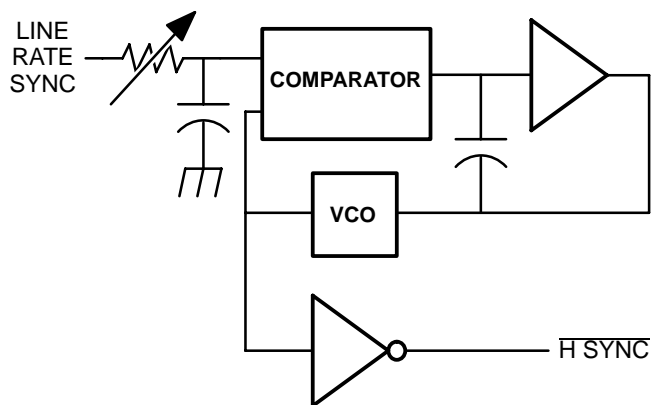

Figure 4-4: Simplified representation of the AFC phase-lock loop.

Horizontal Sync Generator

The Comp Sync, from the Sync Separator on Diagram 1, drives the timing input to U735. U735 is a registered 16-input gate array that outputs line rate enables and $\overline{\text{SYNC}}$. The line rate $\overline{\text{SYNC}}$ output drives U844B, a non-retriggerable one-shot that outputs a pulse wide enough to lock out the twice line rate pulses in the vertical interval. The line rate signal, output from pin 5 (Q), drives the Back Porch Generator (U844A), the Horizontal AFC phase-lock loop (U644), and the sweep trigger selector (U535).

U644 is a phase-locked loop. See Figure 4-4. In this application a second comparator, U947B, is used to drive the internal VCO. The circuit's input, through pin 14, is line rate sync. R536 and C545 form an adjustable delay network that ensures filter or input switching occurs during H Sync time.

U644 has a VCO as one of the onboard functions. Its timing components (C643, R742, and R743) keep the oscillator frequency near line sync rate. When there is line rate sync the output of the comparator will be approximately equal to the U947B + input dc level and no correction voltage will be input to the VCO.

If line rate sync is interrupted, the VCO runs at, or near, line rate until sync is restored. When line rate sync is restored it will be out of phase with the VCO and the internal comparator (U644) will have an output indicating that the loop is unlocked. With an unbalanced input, the second comparator outputs an error signal that will: 1. Attempt to charge the loop filter. 2. Drive the VCO voltage input. When the VCO output changes to a new frequency, the comparator output changes; however, the charge on the loop filter reduces the effect of this change on the comparator in order to slow the loop response. When the loop nears lock the amount of change is very small.

Having H Sync generated by this AFC circuit allows the 1730-Series to sync up on noisy syncs and remain synced up on signals with missing H rate sync pulses. U841D is used as an inverter to output the required $\overline{\text{H SYNC}}$.

The DC Restorer back porch pulse is generated by a one-shot, U844A. When $\overline{\text{SYNC}}$ occurs, U844A is cleared. The next line rate pulse output from U844B will start the one-shot, whose pulse width is determined by C848 and R849. The output pulse from Q99, an emitter follower, is time coincident with the back porch of the input sync signal. The Q output of U844B sets the position of the pulse, and C848 and R849 determine the pulse width.

Vertical Sync Generator

U947A is an integrator whose output is normally low. The broad pulse in the vertical interval will cause its output to ramp up. When the broad pulse ends, and the serrated pulses begin, the output starts ramping back down. This negative-going signal is coupled through C853 to comparator U753B, to output the vertical rate sync pulses (V SYNC).

RGB Amplifier

Under normal operation the base of Q856 is pulled down by CR955, which causes Q855 to saturate and ground the amplifier output. When exerted the $\overline{\text{RGB ENABLE}}$, from the REMOTE connector, is inverted to provide a discharge path for the emitter of CR955, which enables the RGB Staircase Amplifier.

The staircase signal from the REMOTE connector drives an operational amplifier composed of Q856 and Q855, whose gain is approximately 0.5. The amplifier is compensated, for optimum step definition (transient response), by C953. R856, the RGB Offset adjustment, compensates for input dc level variation.

Field ID and Trigger Select

U535 is a 16-input, registered gate array containing a D-type flip-flop. Line rate sync (from U644) drives its Data input, which is clocked through by vertical sync from U753B. Because of the half-line offset between fields, in the vertical sync, alternately a high or a low line rate sync level is clocked out to enable the flip-flop outputs. $\overline{\text{FIELD}}$ is a frame rate square wave that is high for one field and low for the other, that provides field rate timing information to the Micro-processor. The V TRIG output triggers the Field Rate Sweep Generator. There is no field identification for RGB and Remote Sync operating modes.

Non-standard sync inputs may cause the field identifying circuit to stop producing a field rate trigger signal for the Sweep Generator. When this happens, V SYNC is automatically used for triggering (without any field identification taking place). Q806 detects the absence of field identified vertical sync. The field rate square wave output as $\overline{\text{FIELD}}$, keeps C906 charged, which holds pin 19 of U535 high when there is field identification.

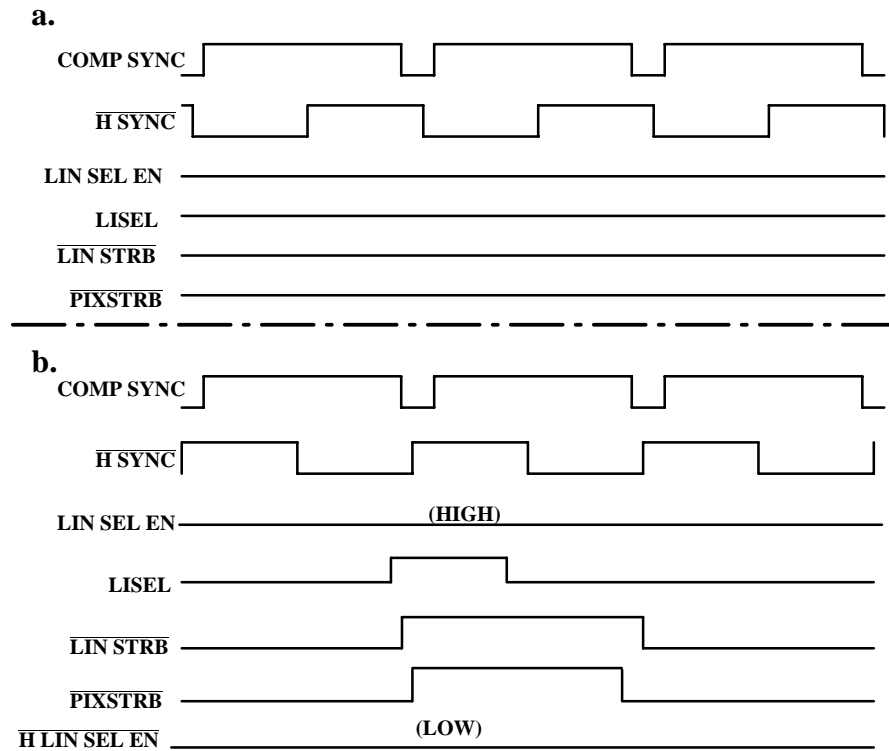

Figure 4-5: Elements for line select timing: a) Line select off. b) 2-field line select.

A one-field trigger can be used, in normal configured instruments, by pulling the REMOTE $\overline{\text{LIN-IFLD}}$ input low to turn on Q821. Turning on Q821 shuts off Q806 and allows C906 to discharge. The resulting low input on pin 19 of U535 switches the V SYNC pulse output to U535 pin 14 to trigger the Sweep Generator at the field rate.

V TRIG is the field rate trigger signal enabling the Sweep Generator, which is positive edge triggered. Field 1 or Field 2 sweep triggering is selected by the $\overline{\text{FLD1/FLD2}}$ control line from the processor. A positive edge is output at the start of the selected field.

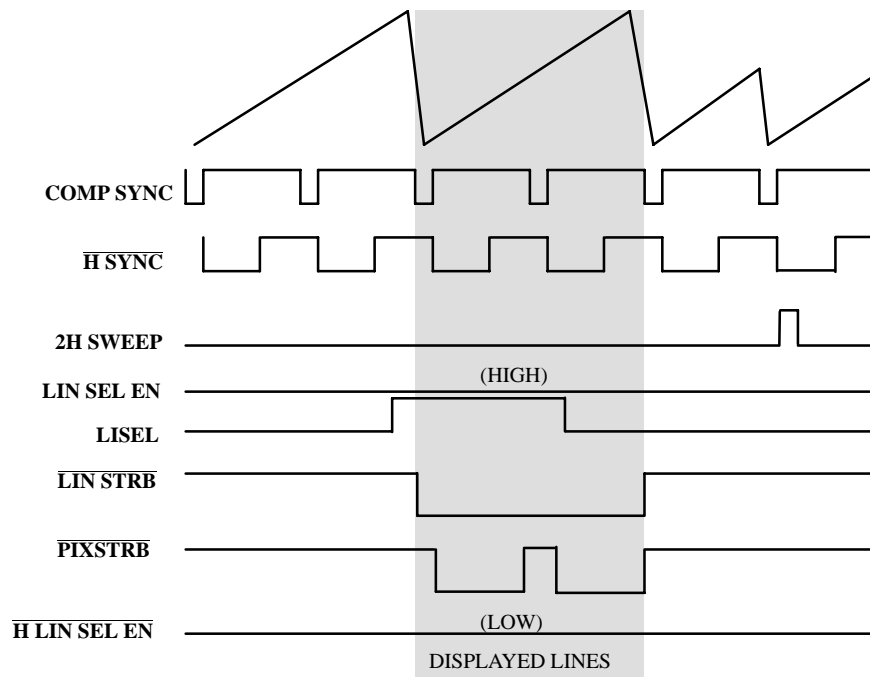

Figure 4-6: Relative line select elements for the 2-line display.

In addition, U535 decodes instructions for selecting either the applied sync (\overline{CAL} high) or the Calibrator (\overline{CAL} low) for the source of line rate sync (H TRIG).

Displaying the appropriate lines in the LINE SELECT mode is achieved by blanking the CRT beam the rest of the time. The LIN SEL signal from the Microprocessor is used by U735 to generate $\overline{LINSTRB}$, which is the blanking signal, and $\overline{PIXSTRB}$, which is the strobe signal for the rear-panel Picture Monitor Output. See Figure 4-5 for timing details.

Figure 4-6 and Figure 4-7 are timing diagrams that show the signal relationships for 2 Line and 1 Line sweep rates in the LINE SELECT mode.

Horizontal and vertical triggering signals enable integrator sweep generators, by dictating when retrace occurs. The output of the selected sweep generator drives a Magnifier Amplifier, which provides sweep magnification, RGB staircase input, and positioning control. The output of the Magnifier Amplifier drives the Output Amplifier to match gain and impedance for the CRT deflection plates. When 1 or 2-line Line Select is displayed readout is switched into the Output Amplifier, for CRT display, on a time sharing basis with the sweep information.

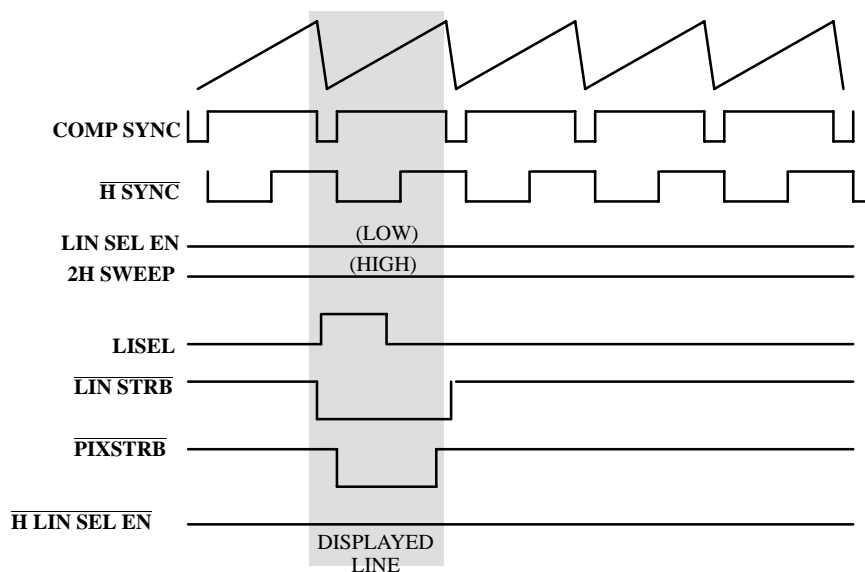

Figure 4-7: Relative line select timing elements for the 1-line display.

Sweep Generators and Horiz Output Diagram 4

Sweep Generator

U552B (Line Rate Sweep Generator) and U552A (Field Rate Sweep Generator) are integrators, one of which is disabled while the other is running. The selection is controlled by the H and V Trigger signals from the Sync Generators (Diagram 3) and the LIN/FLD control line from the Microcontroller. When a trigger arrives, for the selected sweep, the D-type flip-flop (U541A or B) Clear is high and Preset is low, to set Q high and turn on Q451 or Q450, which discharges the integrating capacitor (C448 or C453). See Figure 4-8. The Q output of U541A or B going high also starts a one-shot (U741A or B) which pulls the flip-flop Preset low which assures at least $2\ \mu\text{s}$ (line-sweep one-shot time constant) of discharge (retrace) time. Field sweep one-shot time constant is 2 ms. At the end of the time constant Preset goes high and Clear goes low causing the flip-flop Q output to go low and turn off Q451 or Q450 to start charging the integrating capacitor.

Current source for the integrators is through R654. When a one line or field sweep (including RGB parade) is selected, pin 3 of U735A is pulled low and effectively shorts out R654 to provide more current for a faster sweep. Q750 provides a compensation for 50 Hz sweep by taking away a small amount of current when operating with 625/50 Hz sweep rates.

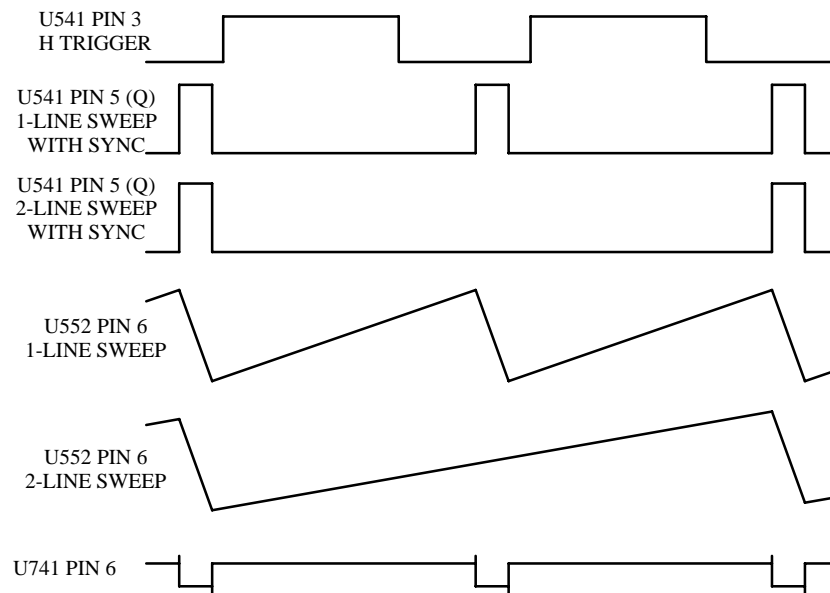

Figure 4-8: Timing signals for 1-line and 2-line sweep.

If there is no H or V Trigger, the output of the running Sweep Generator is self retriggered. When the ramp amplitude reaches about 3/4 of its maximum amplitude U445B trips and sets the flip-flop Preset high to turn on Q451 or Q450 to start retrace. Just before retrace begins U445A also trips and pulls the flip-flop Clear high to lock out the trigger signal.

The Microcontroller-generated 2H SWP PH retriggers the Line Rate Sweep Generator by turning on Q451 (which discharges the integrator capacitor, C453) to synchronize the sweep for Line Select or when dual filtering or input switching is selected.

The output of either one-shot, or LINSEL BLNK, is gated through U334B to become the blanking enable, which ensures that the CRT will be blanked during retrace and unblanked during the portion of active sweep that is to be displayed.

Magnifier Amplifier

An operational amplifier consisting of U564C and D and Q566 positions and magnifies the sweep signal. R557 and R558 are the central elements of the feedback resistor network. The value of the network is altered by R552 ($1 \mu\text{s Cal}$) and R553 ($0.2 \mu\text{s Cal}$) when magnified sweep rates are selected. The junction of input resistance (R559) and the feedback resistance network (R557 and R558) is the amplifier input summing junction.

Horizontal positioning voltage is input to an operational amplifier, U655B, which drives the Magnifier Amplifier summing point (along with the RGB

staircase signal, when RGB/YRGB operation is selected). The length of the sweep, in RGB mode, is set by jumper J456 to accommodate either three- or four-step sweeps (for RGB and YRGB modes).

U465A and U465B are comparators used to sense when the output of the Magnifier and Position Amplifier have driven the CRT beam to the edge of the CRT screen. When the beam is horizontally overdriven, the input to U234C is pulled low to generate the BLANK enabling level for the Z-Axis Amplifier (Diagram 6).

Horizontal Output Amplifier

The Horizontal Output Amplifier is composed of Q858, Q860, Q862, and Q864, with Q868 and Q865 serving as current source. R960 provides the differential mode feedback; R958 and R959 provide the common mode feedback that biases the outputs to approximately 50 volts. The gain of the amplifier is determined by a voltage divider with two adjustments, R660 (Sweep Length Adj.), and magnified sweep registration R661 (Mag Registration Adj.). In LINE SELECT, Q762 and Q763 switch out the horizontal sweep and switch in the horizontal X-Axis component of the line select readout.

Microcontroller Diagram 5

The Microcontroller is the brain of the 1730-Series Waveform Monitor. It monitors the front panel, Store/Recall functions, and the Remote interface. Changes to any switch setting or remote line is converted into appropriate control levels for circuits in the rest of the monitor.

Microprocessor

The 8052 Microprocessor (U522), used as the 1730-Series Microcontroller, contains 8K of masked ROM. The on-board masked ROM holds the Microprocessor machine instructions. Crystal-controlled oscillator frequency is 12 MHz.

The processor operates with an eight-bit multiplexed address/data bus that interfaces through Port 0 (pins 32-39). Front-panel switches and Recall selections are sensed by Port 1 (pins 1-8). Each front-panel momentary contact switch (along with the Recall switches) has a specific row and column address. Functions are changed by simply pushing (to toggle) or pushing and holding a front-panel momentary contact switch. As an example: When row 1 and column 1 are connected together (by switch closure) the sweep rate toggles between the 2-line and 2-field sweep rate; however, if the switch is held in for a discernible interval the processor will switch sweep rate to 1 line.

The I/O Port 2 provides eight additional interface lines. Three lines communicate with the NOVRAM (Clock-pin 21, Data-pin 22, and Chip Enable-pin 23). Four lines (pins 25-28) output high levels to drive analog switching functions

(X5, BLANK DOT, LINSEL, and 2H SWP PH). Pin 24 is the external communications enable that controls the Auxiliary interface.

Pins 13, 14, and 15 input horizontal (line) sync and vertical (field) sync, to decipher line select data and real-time switching functions (A/B and Low Pass/Flat switching). The period for the FIELD, pin 12, determines the phase of the 60/50 control line. The status of this line is held permanently high (1730) or permanently low (1731) for single standard instruments by the positioning of J504. In the 1735 the jumper is not used and the Microprocessor determines the level output on this line. 60 Hz (NTSC) mode of operation is selected for field rates greater than 55 Hz, and 50 Hz (PAL) mode for field rates less than 55 Hz. If signal field rate is close to 55 Hz, the standard selection may be indeterminate and oscillate between 50 and 60 Hz. Automatic standard switching is delayed from the signal switching by several video frames, to ensure that false switching does not occur. If loss of reference occurs, the current standard is maintained until reference is restored. The level of the 60/50 output dictates selection of the Chroma filter and the line numbering for LINE SELECT.

Pins 10 and 11 are the Auxiliary bus (TXD pin 11 and RXD pin 10). U809B and C are buffers for this bus structure which connects directly to a 1720-Series through the rear-panel AUXILIARY connector.

Pin 17 (RD) is the remote input enable for U731, the REMOTE input buffer and U809A, the REMOTE STORE buffer. Pin 16 (WR) enables readout DAC (U325), clocks the I/O Data Latch (U532), and enables the internal registers in the LED Driver (U407).

The functions of the control lines, originating on the Microcontroller diagram, are shown in Table 4–1. The active condition of the line, and the expected result, when active, are detailed here.

Table 4–1: Control Line Functions

Signal Line	State	Result
X5	High	Enables 5X Vertical Magnifier. (U522)
BLANK DOT	High	Blanks between dots in Line Select readout. (U522)
LINSEL	High	Unblanks the CRT for Line Selected line. (U522)
2H SWP PHASE	High	Resets 2H Sweep Generator for Line Select and real-time switching functions. (Q626)
RXD	----	Used in serial port diagnostics and Auxiliary. (U809B)
TXD	----	Sends data to companion 1720-Series. (U809A)
CAL DR		100 kHz pulse to Calibrator. (U331B)
CAL	Low	Enables Calibrator. (U532)
ROEN	High	Enables readout in Line Select. (U532)

Table 4–1: (Cont.)Control Line Functions

Signal Line	State	Result
LIN/FLD	High	1 or 2 Line display. (U532)
LIN/FLD	Low	2 Field display. (U532)
TWO/ONE	High	2 Field or 2 Line display. (U532)
TWO/ONE	Low	1 Line (no single field display possible). (U532)
MAG	High	Enables Horizontal Magnifier. (U532)
EXT	High	Enables internal sync reference. (U532)
EXT	Low	Enables external sync reference. (U532)
FLD 1/FLD 2	High	(NTSC) Field 1 trigger in 2 Field Sweep. (PAL and PAL-M) Field 2 trigger in 2 Field Sweep. (U532)
FLD 1/FLD 2	Low	(NTSC) Field 2 trigger in 2 Field Sweep. (PAL and PAL-M) Field 1 trigger in 2 Field Sweep. (U532)
LIN SEL EN	High	Blanks CRT for Line Select, except during LINSEL high. (U532)
X-AXIS	----	Analog signal to horizontal deflection amplifier for Line Select readout. (U231A)
Y-AXIS		Analog signal to vertical deflection amplifier for Line Select readout. (U231B)
CH B	High	Enables CH-A input. (U884)
CH B	Low	Enables CH-B input. (U884)
ON DCR	Low	Enables DC Restorer. (U884)
3.58	Low	Enables NTSC and PAL-M Chrominance filter. (U884)
4.43	Low	Enables PAL Chrominance filter. (U884)
LPASS	Low	Enables Low Pass filter. (U884)
FLAT	Low	Enables Flat (no filter). (U884)
VAR	Low	Enables vertical variable gain. (U884)
IF 1730 DCRF	Low	Enables fast DC Restorer if ON DCR is high. (U884)

NOVRAM

U725 is the Non-Volatile Random Access Memory (NOVRAM) used to retain the current front-panel status and the front-panel status for the Stored Recalls (Auxiliary). Data is written in and read out through pins 3 and 4; pin 22 of U522 controls the flow of data. The NOVRAM serial clock is output by U522 (pin 21), the Chip Enable is output from U522 pin 23. These three lines (Clock, Data In/Data Out, and Chip Enable) are active when:

- a. Power is turned on.
- b. Any front-panel switch is pressed.
- c. A Store or Recall is requested.

U726 is the power down detection circuit. It detects the loss of instrument power in time for the NOVRAM (U725) to execute a save operation. When the +5 V supply drops a few hundred millivolts, pin 7 is pulled low, which pulls the STR for U725 down, causing it to Store its current status. The front-panel and Auxiliary (Store/Recall) data is saved in a matter of milliseconds when the power starts to drop below safe operating levels. U727 is a three-terminal regulator operating from the +15 V supply, which comes onto the circuit board from the main Power Supply. As soon as the +15 V raises enough to provide a +5 V output from U727, U725 recalls the data saved so that it will be available to the Microprocessor when all supplies are up to their operating tolerances.

- Switch Control** U884 is a serial-in/parallel-out register that is loaded with the real-time switching data from the Microprocessor serial port (pin 10) whenever pin 24 of U522, goes high. When pin 24 is high, the serial input of U884 is enabled and the external communications input, through U809B, is disabled. The eight bits of serial data now in the internal register are clocked out, in parallel, by the leading edge of H (line) Sync, which is the clock signal driving U884 pin 12.
- Address Demux** U527 is the Address DE-MUltipleXer (Demux) used to decode the lower eight bits of the address line. Even though both addresses and data share the same Microprocessor port, only addresses are present when U527 is clocked by the Microprocessor ALE output.
- Readout Drive** U325, through U231A and B, drives the X and Y axes of the dot-scanned line select CRT readout. U325 is a dual D/A Converter (DAC) whose internal registers are loaded from the Data/Address bus and clocked by the Microprocessor WR output.
- I/O Data Latch** U532 is the data latch outputting control signals to the 1730-Series non real-time switching and the readout enable (ROEN). The addresses are loaded from the Address Demux (U527) and clocked out by the Microprocessor WR output. The ROEN operates in conjunction with the Microprocessor Blank Dot output (pin 26) in order to display the data output from U325 on the CRT.
- Cal Drive** U331 divides down the Microprocessor ALE output to generate Cal Drive. U331 is enabled by the CAL from the I/O Data Latch, U532.
- LED Drive** The front-panel LEDs are driven in six common banks by U407. U305 provides a common current drain that is enabled by U407. Data registers in U407 are written into by the Microprocessor over the eight-bit address bus and read out to front-panel LEDs when WR goes low.

Control Circuit Diagram 6

Blanking signals, for video and readout, are input to an intensity switching matrix along with a dc voltage level set by the front-panel INTENS control. Focus level, for the CRT focus anode, is set by regulating the current through a transistor current source. The amount of focus current through the transistor depends on the setting of the front-panel FOCUS control. The effects of small variations in the magnetic field surrounding the instrument are compensated for by an adjustable magnetic field placed around the CRT bulb. Scale Illumination for the CRT face plate is set by controlling the output amplitude of a triangle generator that drives the scale illumination bulbs.

Focus Control The Focus control operation must also control two different display criteria. In the normal mode of operation, the Focus voltage will be selected by the control setting only (Q242 is off). When a Line Select Un-Blanking pulse occurs, U239B turns off and additional current flows through Q242. R245, the LS Focus adjustment, is adjusted for optimum focus in LINE SELECT at the normal display focus setting.

Z-Axis Control U252 is a transistor array with two of the transistors connected as a differential current switch. The static output level (pin 8) is set by the front-panel INTENSity control using Q243 (in the Focus Control) as a current source. The Blanking signal is input to the transistor switching array through U252B (pin 9). When it goes high, the current output, collector of U252A (pin 8), is shut off and the Z-Axis Amplifier (Diagram 9) blanks the CRT. See Figure 4-9.

In LINE SELECT mode, the intensity setting has to change to brighten up the line or lines. This is accomplished by increasing the current through the current source (Q243). U239A is an open collector, dual comparator whose output goes low during Line Select Blanking to allow the full current available, across R238 and R241, to flow in the circuit.

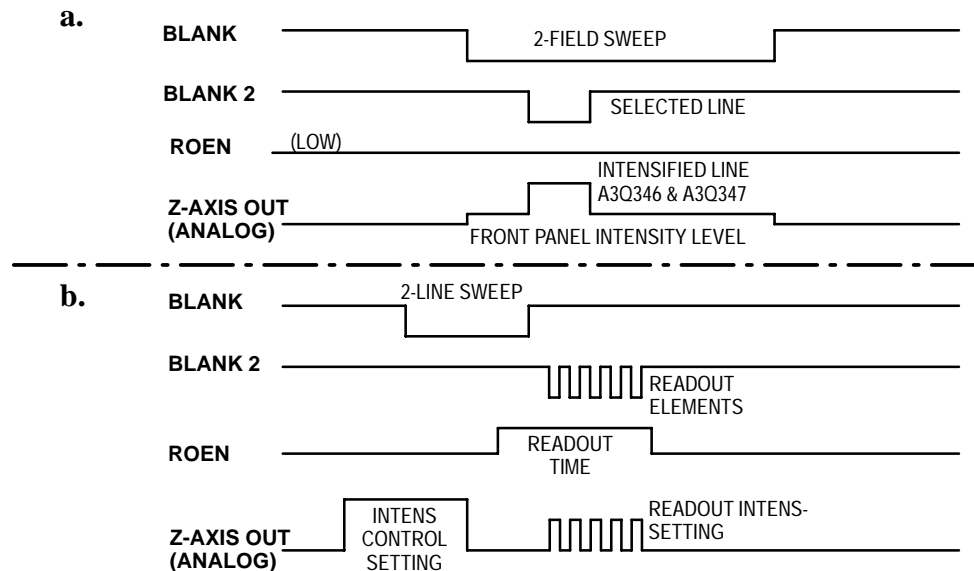

Figure 4-9: Z-axis timing for readout: a) Two-field display intensifies the line (lines) to provide a bright-up strobe. b) In 1- or 2-line sweep, alpha numeric readout in the upper left corner of the CRT is used to convey the number of the first selected line.

Trace Rotation

Trace rotation compensates for changes in the magnetic field surrounding the 1730-Series. Q142 and Q143 are emitter followers to provide Trace Rotation current to the CRT surrounding coil located inside the CRT shield. Amplitude and polarity are controlled by the front-panel ROTATE screwdriver adjustment.

Graticule Illumination

U263A is a triangle generator whose output is compared to the front-panel SCALE control output level, by U263B (a comparator). Whenever the output of U263A is higher than the level from the front-panel SCALE control, Q158 is turned on and current is drawn through the bulbs (DS100, DS200, and DS300) to ground. The duty cycle of Q158 is determined by the level set by the front-panel SCALE control.

J100 is normally in the 1-2 (Lights Enabled) position. In the 2-3 position, the graticule scale illumination is disabled.

± 11.8 V Regulators

The + and -15 V supplies generated by the main low voltage power supply are further regulated to meet the power requirements of the Main (A3) circuit board. U164 is the regulator; its reference level is set by R167, the -11.8 V Adjust. U172 is the +11.8 V supply regulator and its reference level is set by R168, the +11.8 V Adjust.

Front Panel Diagram 7

The front-panel indicators are driven from Microcontroller light driver register and LED drivers from Diagram 5. The front-panel switches are momentary closure (with some hold for additional function capabilities) that are monitored by the Microprocessor, which is also on the Microcontroller (Diagram 5). In addition a series of front-panel controls provide variable dc operating levels as a means of compensating for variable operating requirements and conditions.

Indicators and Switches

The front-panel LED indicators are arranged in six columns returned to a current source by four returns, designated as rows, in order to provide the Microprocessor with a set of column/row matrix addresses. An LED indicator lights when there is a complete circuit from the Light Driver (Diagram 5) through the LED and back to the Light Driver.

Switches complete a simple matrix that is read by Port 1 of the Microprocessor. A completed circuit through the processor (switch closure) dictates an output through the Data I/O that changes one or more operating conditions. Some of the switches are read in two different ways by the Microprocessor. When touched and released they cause the Microprocessor to toggle to the next item on that switch's menu. When held in, the Microprocessor selects a specific operation. Hold for function switching options are outlined in blue on the front panel.

Controls

A set of variable controls consisting of the Horizontal Position, Vertical Position, Vertical Calibration, Scale, and Focus controls select a dc voltage level between +11.8 V and -11.8 V.

The INTENSity control operates in conjunction with the Z-Axis Control circuit on Diagram 6. DC levels for Intens 1, Intens 2, and Intens 3 depend on the operating mode selected, which dictates the level on each of the leads.

Low Voltage Power Supply Diagram 8

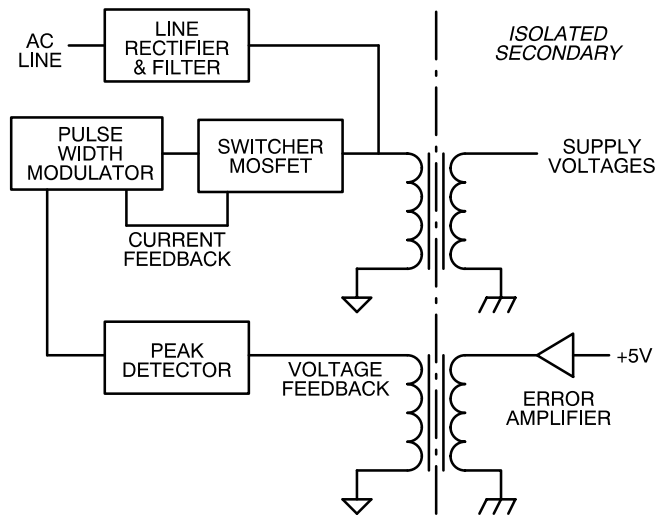

The Low Voltage Power Supply converts the mains line voltage (90–250 VAC) to supply the power requirements of the instrument. The voltages supplied by the Low Voltage Power Supply are +40 V, ± 15 V, and +5 V.

The Low Voltage Power Supply is called a Flyback Switcher. When switcher mosfet Q9 is turned on, its drain voltage drops to approximately 0 V. The current through the 350 μ H primary winding of T3 begins ramping up. The voltages present at all secondaries is such that the rectifier diodes are reverse biased. Energy is being stored in the magnetic field of T3. When Q9 turns off, the drain voltage “flies back” in a positive direction. Current now flows in all of the secondary windings and supplies power.

Line Rectifier and Filter

The input line voltage is filtered by the rear-panel connector to reduce the electrical noise conducted into or out of the instrument. R89 limits the initial charging current through the rectifier diodes and C54.

CR21, CR22, CR23, and CR24 form a bridge rectifier. C54 filters the 110 to 350 VDC rectifier output. L4 filters the switching noise produced by the switcher. R102 reduces the circulating current in the parallel circuit consisting of L4 and C44. DS4, R93, and R94 form a line voltage indicator. R91 and R92 charge C42. C42 provides power to U5 until the primary housekeeping winding provides power through CR17.

Pulse Width Modulator

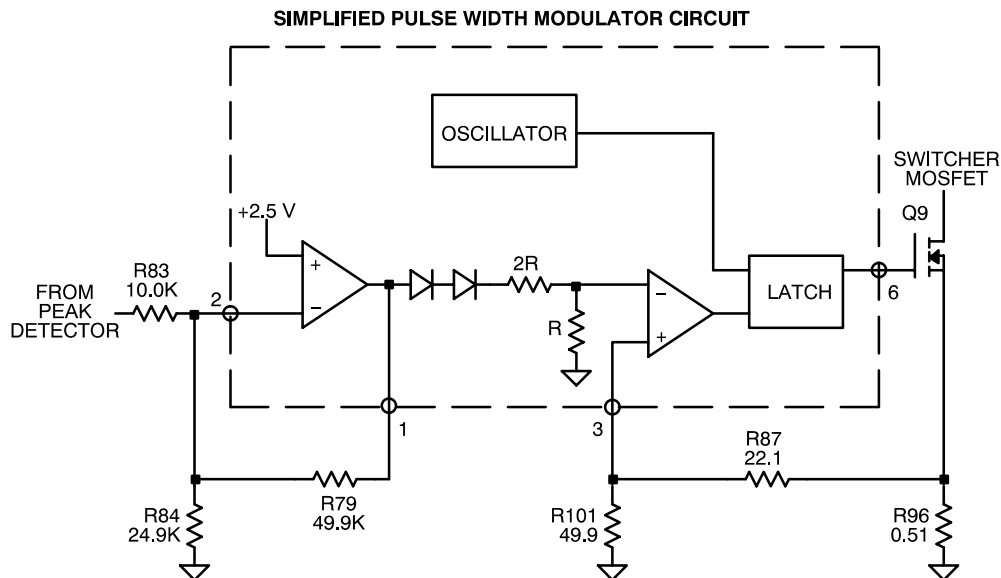

U5 is a current-mode Pulse Width Modulator (PWM). A current-mode PWM uses two feedback loops. The inner current-feedback loop directly controls the switcher mosfet peak current. The outer voltage-feedback loop programs the inner loop peak current trip point.

U5 pin 2 is the inverting input of an internal op-amp. The non-inverting input is set to 2.5 V by an internal voltage reference. Current from the peak detector flows through R83 and R79. R84 provides a 100 μA offset. The voltage at U5 pin 1 will vary in order to maintain U5 pin 2 at 2.5 V.

The voltage at U5 pin 1 is modified by an internal circuit and sets the trip point of the internal comparator. U5 pin 3 is the external input to the comparator. R88 and C52, connected to U5 pin 4, set the internal oscillator to 80 kHz.

The circuit works as follows: The oscillator resets the latch and U5 pin 6 goes high, turning the switcher mosfet on. The current through the switcher mosfet increases, causing the voltage across R96 to increase. This voltage is divided by R87 and R101, and is applied to the comparator (pin 3). When the voltage at U5 pin 3 reaches the comparator trip point, the latch toggles and the switcher mosfet is turned off. This process is repeated at an 80 kHz rate.

C58 increases the PWM noise immunity by rolling off the internal op-amp frequency response. R82 holds the switcher mosfet off as the circuit is powering up. R81 slows the turn-on of the switcher mosfet while CR27 speeds up the turn off.

Output Filters	The three output windings supply four output voltages. Each output is rectified by a single diode and filtered by an LC pi filter.
Error Amplifier (671-2890-07 and above)	The Error Amplifier regulates the +5 V output by feeding an error signal to the Pulse Width Modulator. VR1 is a 2.5 V shunt regulator containing an op-amp and a voltage reference. The +5 V is divided by R69 and R70 to provide 2.5 V to VR1, with fine adjustment provided by R99. C40 and R71 determine the gain and frequency response of VR1. VR4 controls overshoot of the +5 V at power up. R98 and CR26 provide a minimum operating current for VR1. R68 decouples C39 from VR1. Overvoltage protection for the +5V supply is provided by a crowbar circuit formed by Q11, VR3, R13, and R14.
Feedback Transformer Driver and Peak Detector	The 80 kHz sawtooth waveform at U3 pin 3 trips comparator U3. U3 pin 1 then feeds a trigger pulse to one-shot U4. U4 pin 13 outputs a 300 ns pulse to the 130 mA current source consisting of Q7 and Q8. When Q8 turns on, T2 pin 2 is pulled down until CR15 (Error Amplifier) is forward biased. The negative-going pulse at T2 pin 2 is peak detected by CR16 and C46. The dc voltage present at the anode of CR16 feeds the Pulse Width Modulator and the Output Under-Voltage Shutdown circuit. CR29 resets T2 between pulses.
Output Under-Voltage Shutdown	If the +5 V is below 4.9 V, the Error Amplifier will cause the Peak Detector output to go below 2.9 V. The output of comparator U3B will pull low and shut down Pulse Width Modulator U5. C47 and R96 delay the operation of U3B long enough for the power supply to power up. If the +5 V does not reach 4.9 V within 50 ms of power up, U3B will shut down the switcher. The power supply will then cycle on and off every couple of seconds.

High Voltage Power Supply Diagram 9

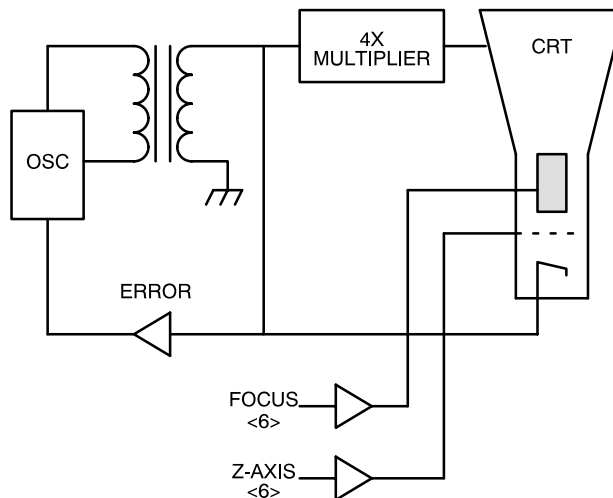

The High Voltage Power Supply generates the heater, cathode, control grid, focus anode, and post accelerating potentials required to display the outputs of the Vertical and Horizontal Output Amplifiers.

HV Osc and Error Amp

The High Voltage Power Supply is generated by a sine-wave oscillator and step-up transformer. Q6 and T1 are the principal elements of an Armstrong oscillator running at about 22 kHz. Error Amplifier U2 regulates the +100 V output and keeps the High Voltage Power Supply constant under varying load conditions by controlling the base current to Q6. The +100 V output is regulated directly, while the High Voltage Power Supply is indirectly regulated through a current feedback circuit.

R48, C16, R60, and R64 form the High Voltage Power Supply current feedback circuit. As the current from the High Voltage Power Supply is increased, the voltage to the + side of the Error Amplifier (U2) increases, which increases the base drive to Q6, the HV Osc. This current feedback compromises the regulation of the +100 V supply to keep the high voltage constant with varying intensities.

C66 and Q10 are a start delay circuit that holds the Error Amplifier output low, through CR30, until C66 is charged. Delaying the start of the high voltage oscillator allows the Low Voltage Power Supply to start, unencumbered by the load from the high voltage oscillator.

Power Supply Outputs

CR4 is the high voltage rectifier. Filter capacitors C3, C4, and C8 work with CR4 to provide -2530 V to the CRT cathode. U1 is a four-times multiplier providing +11 kV to the CRT anode.

Focus Amplifier

Q1 and Q2 form an operational amplifier that sets the voltage at the bottom of the focus divider. The front-panel FOCUS pot determines the voltage at the bottom of the focus divider. The Center Focus control, R11, is set for optimum beam focus, as viewed on the CRT, with the front-panel FOCUS control set to mid range. Once the Center Focus adjustment has been set, adjusting the front-panel FOCUS control changes the voltage at the bottom end of the divider and, consequently, the voltage on the CRT focus anode.

Grid Drive Circuit

The cathode of the CRT is at a -2750 V potential with the grid coupled to the Z-Axis Amplifier by the grid drive circuit. The grid is approximately 75 V negative with respect to the cathode. The 200 V p-p sine wave present at the cathode of CR8 is input to the Grid Drive circuit where it is clipped for use as CRT control grid bias.

The sine wave from the cathode of CR8 is coupled through R47 to a clipping circuit consisting of CR5 and CR6. Clipping level for the positive excursion of the sine wave is set by the CRT Bias adjustment, R58. The negative clipping level is set by the front-panel INTENSITY control through the Z-Axis Amplifier. The clipped sine wave is coupled through C11 to a rectifier made up of CR1 and CR3. The rectified, clipped sine wave is the CRT control grid bias voltage. C9 couples the blanking signal from the Z-Axis Amplifier to the CRT control grid. DS1 and DS2 limit the CRT grid to cathode voltage at instrument turn on or off. DS3 limits the CRT heater to cathode voltage.

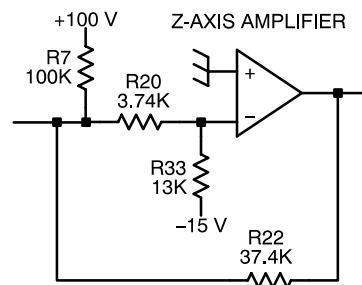
Z-Axis Amplifier

This is an inverting amplifier with negative feedback. R22 is the feedback resistor while R7, R20, and R33 act to maintain the summing junction at $+5$ V. Without any Z-Axis input current, the amplifier output is approximately $+10$ V. Negative Z-Axis input current will cause the output to go positive.

Q5 is a current amplifier feeding the output stage. Q3 and Q4 form a push-pull output stage. Q3 acts as a 2.7 mA constant current pull-up, while Q4 is the pull-down transistor. C6 speeds up the amplifier by coupling ac signals to the base of Q3. CR2 and R41 protect the amplifier during CRT arcing.

CRT The pinout for the CRT is shown in Figure 4-3.

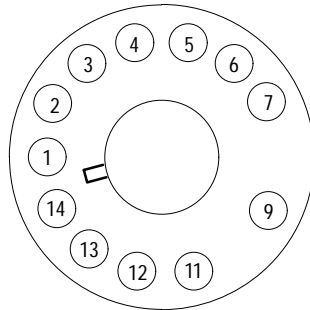

<u>Pin</u>	<u>Description</u>
1	Filament (f)
2	Cathode (k)
3	GRID (g1)
4	FOCUS (g3)
5	ASTIG (g4)
6	GEOM (g5)
7	VERT PLATE (y2)
9	VERT PLATE (y1)
11	HORIZ PLATE (x2)
12	1st ANODE (g2)
13	HORIZ PLATE (x1)
14	Filament (f)

Figure 4-10: Pinout of the CRT Socket



Checks and Adjustments

Section 5

Checks and Adjustments

This section consists of two separate procedures. The first, a Performance Check, is used to determine compliance with the Performance Requirements in the Specification. The second is the Adjustment Procedure that provides the instructions on how to adjust the instrument and return it to operation within the specification.

In both procedures, front- and rear-panel controls and connectors on the instrument under test are fully capitalized (e.g., 2LINE SWEEP). Control and connector names on test equipment and internal controls and adjustments for the instrument under test are initial capitalized (e.g., Time/Div, Geometry, etc.).

Limits, tolerances, and waveforms given in this section are guides to adjustments and checks, and are not instrument specifications, except when listed in the Performance Requirement column of the Specification section of this manual.

Recommended Equipment List

The following equipment and accessory items are required to do the Performance Check and/or Adjustment Procedures. Broad specifications are followed by an example of equipment that meets these specifications; in most cases, the recommended instrument was used in preparing the procedures that follow.

Electrical Instruments

1. Test Oscilloscope

Vertical Amplifier:

30 MHz Bandwidth, 1 mV Sensitivity.

Time Base:

10 ns/div to 5 ms/div sweep speeds, triggering to 5 MHz.

For example: a TEKTRONIX TAS 465 Oscilloscope. Also 10X probes, P6106 (Tektronix Part No. 010-6106-03), and a 1X probe, P6101 (Tektronix Part No. 010-6101-03).

2. Television Signal Generator

Color test signals for the television standard of the monitor to be tested: color bar signal, linearity staircase with variable APL, pulse and bar (with 2T

pulse, 2T bar, and modulated pulse signals, and field square wave signal), multiburst signal, and black burst signal.

For example: NTSC TEKTRONIX 1410 with Option AA and Option AB (modified SPG2 and TSG7), TSG3, TSG5, and TSG6.

PAL TEKTRONIX 1411 with Option AA and Option AB (modified SPG12 and TSG11), TSG13, TSG15, and TSG16.

PAL–M TEKTRONIX 1412 with Option AA and Option AB (modified SPG22 and TSG21), TSG23, TSG25, and TSG26.

NOTE. *The 1410–Series generators with standard SPG and TSG modules can be used, but not all checks and adjustments can be made. A standard SPG2, SPG12, or SPG22 module will not check lock to changes in sync amplitude, cw lock to changes in burst amplitude, and frequency lock to burst offset frequency changes.*

The 1410, 1411, and 1412 Option AB are mainframes with modified TSG7 and TSG11 Color Bar generators that provide more accurately controlled output amplitudes.

The signal generators can be ordered with one or both options (AA and AB).

The TSG3, 13, and 23 are Modulated Staircase generators with variable APL.

The TSG5, 15, and 25 are Pulse and Bar generators with modulated pulse and field square wave signals.

The TSG6, 16, and 26 are Multiburst generators.

3. **Sine wave generator**, at least 250 kHz to 10 MHz.

For example: A TEKTRONIX SG503 Leveled Sine Wave Generator installed in a TEKTRONIX TM500 Series Power Module.

4. **Function Generator**

Sine Wave frequencies: 90 Hz to 2 kHz.

Amplitude: 0.1 V to 10 V p-p when loaded by 75 Ω .

For example: TEKTRONIX FG501A Function Generator installed in a TEKTRONIX TM500 Series Power Module.

5. **Voltmeter**

Range, 0 to greater than 100 Vdc; accuracy, $\pm 0.1\%$.

For example: TEKTRONIX DM504A in a TM500 Series Power Module.

6. Frequency Counter

Range, 100 kHz to 5 MHz; accuracy, $\pm 0.001\%$.

For example: TEKTRONIX DC503A in a TM500 Series Power Module.

7. Video Amplitude Calibrator

Signal, adjustable square wave 0.0 to 999.9 mV p-p with a resolution of 0.1 mV and an accuracy of 0.05%; frequency approximately 270 Hz.

For example: TEKTRONIX 067–0916–00 in a TM500 Series Power Module.

8. Power Module

for powering and housing TEKTRONIX DM501A, DC503A, FG503, 067–0916–00, and 015–0408–00.

For example: A TEKTRONIX TM506 Power Module.

9. Variable Autotransformer

For example: General Radio Metered Auto Transformer W10MT3W. If 220 volt operation must be checked, a conversion transformer or appropriate 220 volt autotransformer is needed.

10. Spectrum Analyzer with Tracking Generator

Bandwidth ≥ 10 MHz and sensitivity to 50 dB.

For example:

TEKTRONIX 2712 Opt 04

Auxiliary Equipment

11. Peak to Peak Detector Amplifier and Detector Head

Facilitates differential frequency–response measurements. Provides a high–impedance load and bias for the Peak To Peak Detector Head.

For example: TEKTRONIX 015–0408–00 Peak To Peak Detector Amplifier, includes one 015–0413–00 Peak To Peak Detector Head.

12. Step Attenuator

75 Ω constant impedance attenuator variable from 0 to 40 dB in 1 dB steps.

For example: A Wavetek 75803 Step Attenuator.

13. RF Bridge

Range, at least 46 dB return loss sensitivity, 50 kHz to 6 MHz.

For example: Wide Band Engineering Part No. A57TSCR. Also, a 75 Ω precision Termination for use with RF Bridge, Wide Band Engineering Part No. A56T75B.

14. 75 Ω Terminators

Three required, one should be a feed-through type.

For example: End-line, 75 Ω terminator (Tektronix Part No. 011–0102–00) and a feed-through 75 Ω terminator (Tektronix Part No. 011–0103–02).

15. 75 Ω Coaxial Cable

Three required.

For example: 42-inch RG59U (Tektronix Part No. 012–0159–00).

16. 10X, 75 Ω Attenuator

For example: Tektronix Part No. 011–0061–00.

17. Alligator Clip to BNC Adapter

For example: Tektronix Part No. 013–0076–00.

18. Dual Input Coupler

Matched bnc cable-T for making phase comparisons between two inputs. Matched length of the two arms within ± 0.1 inch.

For example: Tektronix Part No. 067–0525–02.

19. Precision 50 Ω Coaxial Cable

For example: Tektronix Part No. 012-0482-00 (used with the SG503).

20. 50 Ω -to-75 Ω Minimum Loss Attenuator

For example: Tektronix Part No. 011-0057-00.

21. Parade Display Test Connector

A 15-pin sub-miniature D-type connector (for example: Tektronix Part No. 131-0459-00), modified to enable and test the RGB Parade input. See Fig. 5-1.

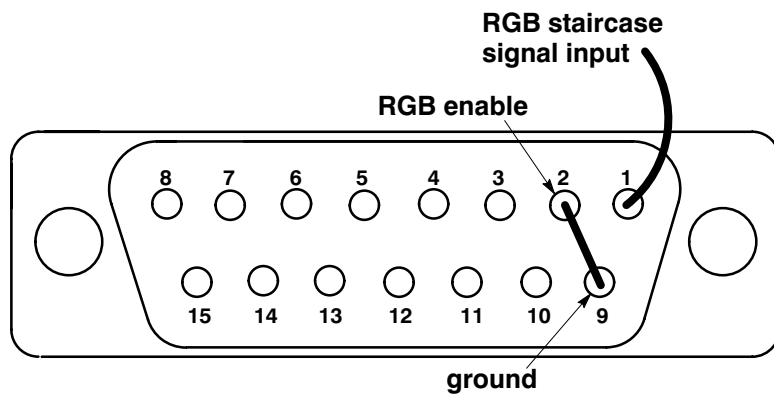

Figure 5-1: Remote connector for RGB.

22. 90/100 Hz Test Connector

A 15-pin sub-miniature D-type connector (for example: Tektronix Part No. 131-0459-00), modified to enable and test the 90/100 Hz triggering. See Fig. 5-2.

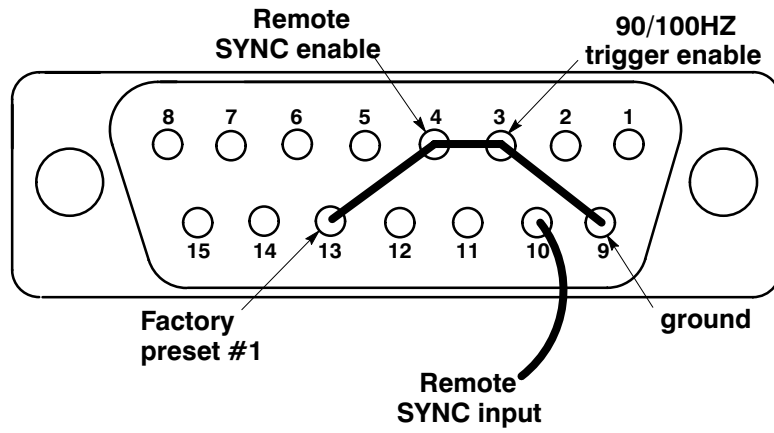

Figure 5-2: Remote connector for 90/100 triggering.

Performance Check

The Short-Form Procedure is intended for those who are familiar with the complete Performance Check procedure. Step numbers and sub-step designations correlate directly to the steps in the Performance Check Procedure; this makes it possible to use the Short-Form Procedure as a table of contents.

Short-form Procedure

1. Preliminary Setup

- b. Connect autotransformer.
- c. Connect composite color bar signal.

2. Power Supply Operation

- c. Check for stable operation over the prescribed voltage range.

3. Calibrator Frequency

- c. Check Calibrator frequency.
- d. Check that Calibrator is synchronized in 1LINE and 2LINE SWEEP.
- e. Check that Calibrator free runs in 2FLD SWEEP.

4. Sync Separation

- a. Check instrument synchronization.

5. Sweep Operation

- b. Check sweep modes.
- d. Check for 1LINE and 2LINE SWEEP rates.
- e. Check for 2FLD SWEEP.
- g. Check that some portion of field blanking is displayed. (2H Mag.)
- i. Check that some portion of horizontal blanking is displayed. (2 Line Mag.)
- j. Check that each field in 2LINE MAG SWEEP can be positioned onto the screen.

6. Sweep Calibration

- d. Check 2LINE SWEEP accuracy.

- e. Check 2LINE SWEEP linearity.
- h. Check 1LINE SWEEP accuracy and linearity.
- j. Check 1 μ s SWEEP accuracy and linearity.
- q. Check 0.2 μ s SWEEP accuracy and linearity.

7. RGB/YRGB Parade Display

- d. Check shortened sweep length.
- e. Check sweep rate and magnification.
- f. Check range of HORIZONTAL Position control.
- h. Check added deflection.

8. 90/100 Hz Triggering

- j. Check for stable display while varying generator frequency.

9. Vertical Gain and X5 Gain Registration

- f. Check 5X gain accuracy.
- h. Check VARIABLE GAIN control range – upper.
- i. Check VARIABLE GAIN control range – lower.
- n. Check X5 Gain registration.
- r. Check CH–B amplifier gain.

10. Calibrator Amplitude

- b. Check Calibrator amplitude.

11. PIX MON OUT Operation

- e. Check PIX MON OUT level.
- h. Check dc level shift for intensified line.
- j. Check PIX MON OUT amplitude.

12. DC Restorer Operation

- b,c. Check that DC Restorer operates.
- i. Check SLOW DC RESTORER.
- k. Check FAST DC RESTORER.
- p. Check DC RESTORER with APL change.

- s. Check DC RESTORER with loss of burst.

13. Flat Response

- d. Check CH-B flat response.
- g. Check CH-B X5 flat response.
- j. Check CH-A X5 flat response.
- l. Check CH-A flat response.

14. PIX MON OUT Frequency Response

- d. Check Frequency Response.

15. Transient Response

- c. Check preshoot, overshoot, and ringing.
- d. Check pulse-to-bar ratio.
- e. Check bar tilt.
- g. Check field tilt.
- k. Check chrominance-to-luminance gain and delay error.

16. X5 Transient Response

- d. Check preshoot, overshoot, and ringing.
- e. Check pulse-to-bar ratio.

17. Low Pass Filter Response

- e. Check amplitude difference from Flat to Filter.

18. Chroma Filter Response

- d. Check CHROMA Filter gain.
- g. Check CHROMA Filter cutoff.

19. Return Loss

- e. Check Input loop-through return loss.
- h. Check PIX MON OUT return loss.

Performance Check Procedure

1. Preliminary Setup

- a. Set up the 1730-Series front-panel controls as shown in Table 5-1.

Table 5-1. Preliminary Control Settings

POWER	ON
INTENSITY	Set to preference
FOCUS	---
SCALE	---
VERTICAL Position	Set later
HORIZONTAL Position	Set later
FILTER	FLAT
REF	INT
INPUT	B
GAIN (switch)	off
DC REST	OFF
MAG	off
SWEEP	2LINE
FIELD	FLD1
LINE SELECT	off

- b. Connect the 1730-Series ac power cord to the variable autotransformer. Turn power on and set the autotransformer for either 110 or 220 Volts.
- c. Connect a composite color bar signal with 100% peak white bar and 75% amplitude color bars to the CH-B INPUT and terminate the opposite side of the loop-through with a 75 Ω termination.

2. Check Power Supply Operation

REQUIREMENT – Check ac input range, 90–132 V or 180–250 V.

- a. Turn on the 1730-Series and adjust the controls for a usable display.
- b. Vary the autotransformer from 90–132 V or 180–250 V.
- c. **CHECK** – for stable operation over the voltage range.

- d. Return the autotransformer to 110 or 220 Volts.

3. Check Calibrator Frequency

REQUIREMENT – Frequency 100 kHz \pm 100 Hz, Synchronizes 1LINE and 2LINE SWEEP (free runs in 2FLD).

- a. Connect a X10 probe from the frequency counter to the blue CRT lead on the 1730-Series Main circuit board.
- b. Display the CAL signal at the 2LINE SWEEP rate.
- c. **CHECK** – that the frequency of the Calibrator is 99.9 to 100.1 kHz.
- d. **CHECK** – that the Calibrator is synchronized in both 1LINE and 2LINE SWEEP.
- e. **CHECK** – that sweep free runs in 2FLD.

4. Sync Separation

REQUIREMENT – Check for stable sweep synchronization; internally 40 IRE (300 mV) \pm 6 dB, and externally 143 mV to 4 V.

- a. **CHECK** – that the 1730-Series instrument can be synchronized to the amplitudes shown in Table 5–2, using the 1410-Series Option AA test signal generator. Check both 2LINE and 2FLD SWEEP for stable triggering.

Table 5–2. Amplitude

REFERENCE SOURCE	SIGNAL	AMPLITUDE OF SYNC
Internal	Composite Video	143 mV to 572 mV (NTSC and PAL–M) 150 mV to 600 mV (PAL)
EXT REF	Composite Sync or Video	143 mV to 4 V (NTSC and PAL–M) 150 mV to 4 V (PAL)

NOTE. Use the 1410-Series Option AA Variable Sync Amplitude control to change composite video sync amplitude. If the 1410-Series Option AA is not available, use the step attenuator with a non-terminated input. The step attenuator, set to 0 dB and 12 dB attenuation, yields 0.5 and 2X sync amplitude.

5. Sweep Operation

REQUIREMENT – Check that the correct sweep rate can be selected. Check that some part of the blanking interval is displayed when magnifying the centered 2LINE and 2FLD sweeps.

- a. Display INPUT A with nothing connected.
- b. **CHECK** – that a sweep occurs at each SWEEP rate (2LINE, 2FLD, and 1LINE).
- c. Select CH–B INPUT.
- d. **CHECK** – that the 1LINE and 2LINE SWEEP modes display one line and two lines of the color bar, respectively.
- e. **CHECK** – for a 2FLD SWEEP display of the color bar signal.
- f. Select and center the 2FLD SWEEP, then push the MAG button.
- g. **CHECK** – that some portion of the vertical (field) blanking interval is displayed.
- h. Select and center the 2LINE SWEEP, then push the MAG button.
- i. **CHECK** – that some portion of the horizontal (line) blanking interval is displayed.
- j. **CHECK** – that both lines of the 2LINE MAG SWEEP can be positioned onto the display with the HORIZONTAL Position control.

6. Check Sweep Calibration

REQUIREMENT – Timing accuracy: For 10 μ s/div. (2 LINE), 5 μ s/div. (1 LINE), and 1 μ s/div. (2 LINE+MAG): $\pm 2\%$. For 0.2 μ s/div. (1 LINE+MAG): $\pm 3\%$. Linearity: $\pm 1\%$.

- a. Hold the 1730–Series REF button in until the calibrator signal is displayed.
- b. Turn off the HORIZONTAL MAG and select 2 LINE.
- c. Use the HORIZONTAL Position control to place the first falling calibrator transition on the 10 μ s graticule mark (the timing mark on the left side of the graticule that goes completely through the blanking line). See Fig. 5-3.

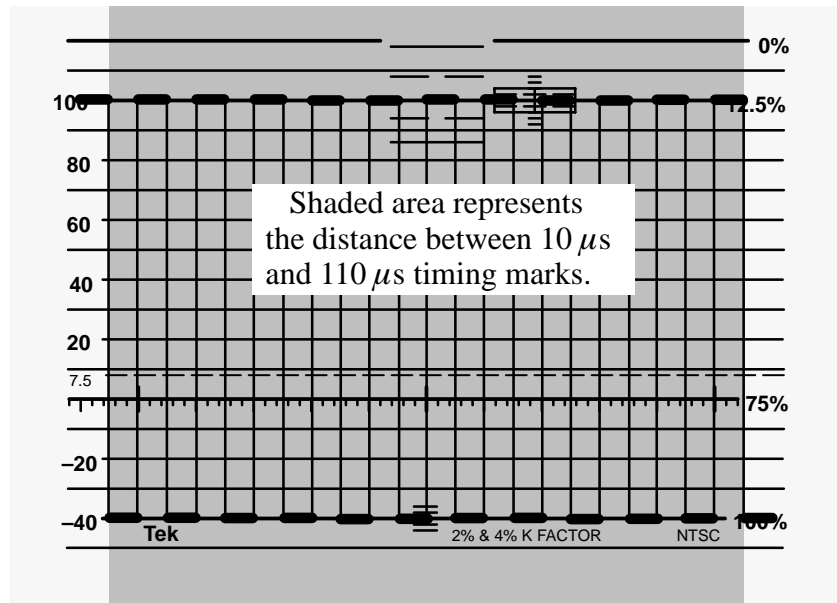

Figure 5-3: Ten full cycles of calibrator signal between timing marks.

- d. **CHECK** – for 10 full cycles of calibrator signal in the 10 center major graticule divisions, $\pm 2\%$ (1 minor division). Adjust the front-panel H CAL to place the 11th falling transition *exactly* on the 110 μs graticule mark (the timing mark on the right side of the graticule).
- e. **CHECK** – that no falling transition between the 10 μs and the 110 μs graticule marks is more than 1% (0.5 minor division) from a major graticule mark.
- f. Select 1 LINE SWEEP (push and hold).
- g. Use the HORIZONTAL Position control to place the first calibrator transition on the 5 μs graticule mark (left side graticule timing mark).
- h. **CHECK** – for five full cycles of calibrator signal in the center 10 major graticule divisions, $\pm 2\%$ (1 minor division).
- i. Select 2 LINE SWEEP and turn on the HORIZONTAL MAG.
- j. **CHECK** – for 1 full cycle of calibrator signal in the center 10 divisions of the graticule, $\pm 2\%$ (1 minor division).
- k. Connect the multiburst output from the television signal generator to the 1730-Series CH-A INPUT. Connect the other side of the loop-through to the digital counter input.
- l. Set the multiburst generator to Low, Continuous, and Manual. Turn Markers off.

- m. Adjust the multiburst Frequency for a 5 MHz sine wave as measured on the digital counter.
- n. Select the 1730–Series INT REF and 1 LINE SWEEP. Turn on the MAG and VAR GAIN. Adjust the VAR GAIN control for approximately six vertical divisions of display.
- o. Set the multiburst generator to Composite.
- p. Use the 1730–Series HORIZONTAL Position control to display all but the first and last 10% of the sweep.
- q. **CHECK** – for 10 cycles over 10 graticule divisions, ± 1.5 minor divisions.
- r. Switch the multiburst generator to Continuous and check that its frequency, as measured on the digital counter, remains set at 5 MHz. Return to Composite.
- s. Repeat parts q and r of this step several times to ensure an accurate check.

7. RGB/YRGB Parade Display

REQUIREMENT – Attenuated sweep: 3.4 to 4.1 div. for 3–step or 2.5 to 3.1 div for 4–step. Staircase input gain: 10 V = 9 horizontal divisions ± 1.4 div. Attenuated sweep responds to sweep rate and magnification controls.

- a. Connect the color bar signal to the CH–A INPUT. Terminate the open side of the loop–through with a 75Ω end–line terminator.
- b. Display the color bar in 1LINE. Center the display. Note the position of the plug on J456 on Assembly A3 that selects the 3– or 4–step Parade display. The 2–3 position selects attenuation for a 3–step display.
- c. Connect the Parade Display Test Connector to the REMOTE connector. See Fig. 5-1.
- d. **CHECK** – that the sweep has shortened to 3.4 to 4.1 divisions if P456 is set to a 3–step display, or 2.5 to 3.1 divisions if the plug on J456 (1–2) is set for a 4–step display.
- e. **CHECK** – that the shortened sweep is 1LINE or 2FLD, according to the SWEEP controls, and that the sweep can be magnified.
- f. **CHECK** – that the display can be moved to the sides of the screen with the HORIZONTAL Position control. It may be necessary to adjust R856.
- g. Position the display to the right side of the screen; it may be necessary to adjust R856, RGB Offset, to increase range of positioning. Fig. 5-7

shows the location of R856. Connect a 0 to +10 V, 2 kHz square wave to the bnc connector of the Parade Display Test Connector, as shown in the equipment list.

- h. **CHECK** – that 7.6 to 10.4 divisions of deflection have been added by the square wave.

8. Check 90/100 Hz Triggering

REQUIREMENT – 90 Hz, $\pm 15\%$ (100 Hz, $\pm 15\%$).

- a. Connect the function generator output through a dual input coupler and an in-line 75Ω terminator to the 1730-Series CH-A INPUT.
- b. Set the function generator for a 90 Hz (100 Hz PAL) 2 V p-p square wave.
- c. Install the bnc to alligator clip adapter on the remaining side of the dual input coupler.
- d. Install the 90/100 Hz sub-miniature D-connector on the 1730-Series REMOTE connector. See Fig. 5-2.
- e. Connect the alligator clip from the center connector (red) to pin 10 of the sub-miniature D-connector adapter.
- f. Move the jumper for J540 (90/100 Hz Enable) to the 1-2 position. See Fig. 5-7.
- g. Move the jumper for J635 to the negative position (2-3). See Fig. 5-7.
- h. Select 2FLD SWEEP.
- i. Set the 1730-Series VAR GAIN for a 1 V p-p square wave, 90 Hz output (100 Hz PAL).
- j. **CHECK** – that the display remains stable (although sweep length varies) while varying the generator from 76 to 104 Hz (85-115 Hz PAL).
- k. If 90/100 Hz triggering is not going to be used, move the jumpers on J540 to the 2-3 position and J635 to the 1-2 position.
- l. Remove the adapter from the 1730-Series rear-panel REMOTE connector.

9. Check Vertical Gain and X5 Gain Registration

REQUIREMENT – Gains within 1% for both CH-A and CH-B INPUT. X5 gain within 5%. Input signals between 0.8 and 2 V can be adjusted to full-scale

video amplitude with the VARIABLE gain. Less than 1 major division shift from baseline between unmagnified and magnified signal.

- a. Connect the Video Amplitude Calibrator (VAC) to the CH-A INPUT. Connect the linearity output of the television test signal generator to the CH-B INPUT. Do not terminate either loop-through. See Fig. 5-4.

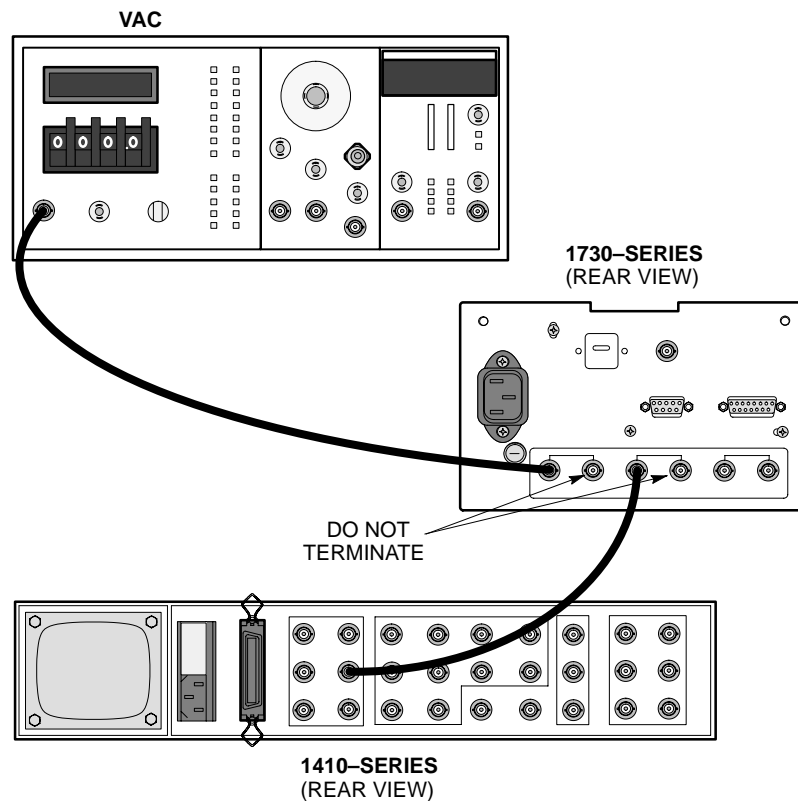

Figure 5-4: Equipment hook-up for checking vertical gain.

- b. Set the VAC to 999.9 mV.
- c. Select CH-A.
- d. Adjust VCAL for exactly 140 IRE (1.00 V).
- e. Set the VAC to 0.200 V and change the 1730-Series gain to X5.
- f. **CHECK** – that the display is 133 to 147 IRE (0.950 V to 1.05 V).
- g. Select CH-B INPUT.

- h. **CHECK** – Turn on the 1730-Series VARIABLE gain (X5 is off) and adjust the VARIABLE control for a sync pulse amplitude greater than 100 IRE (720 mV for PAL).
- i. **CHECK** – Adjust the 1730-Series VARIABLE control for a display amplitude of 140 IRE (1.0 V for PAL) or less.
- j. Turn off 1730-Series VAR GAIN.
- k. Terminate the CH-B loop-through with a 75 Ω termination.
- l. Use the VERTICAL Position control to place the signal blanking level on the baseline.
- m. Select X5 GAIN.
- n. **CHECK** – for less than 1 major division of baseline shift when switching between X1 (Gain off) and X5 GAIN.
- o. Turn off X5 GAIN.
- p. Connect the VAC to the CH-B INPUT. Do not terminate the loop-through.
- q. Set the VAC for a 999.9 mV square wave.
- r. **CHECK** – that the vertical amplitude of the display of the 1730-Series is 138.6 to 141.4 IRE (0.990 V to 1.010 V).
- s. Disconnect the VAC from the 1730-Series.

10. Check Calibrator Amplitude

REQUIREMENT – Amplitude 1 V \pm 1%.

- a. Push the REF and hold it in until the calibrator signal is displayed.
- b. **CHECK** – the 1730-Series for a displayed amplitude of 138.6 to 141.4 IRE PAL (0.990 V to 1.010 V).

11. Check PIX MON OUT Operation

REQUIREMENT – Gain from Input 1:1 \pm 5% at 15 kHz. Dc level within \pm 0.5 V of 0 V. Selected line dc offset by approximately 180 mV.

- a. Install a 75 Ω terminator on the CH-A INPUT.
- b. Select CH-A and 2LINE SWEEP.
- c. Connect a coaxial cable from the PIX MON OUT to the test oscilloscope. Use an in-line terminator at the test oscilloscope. Connect the

Composite Sync from the television test signal generator to the 1730-Series EXT REF and terminate remaining side of the loop-through input. See Fig. 5-5.

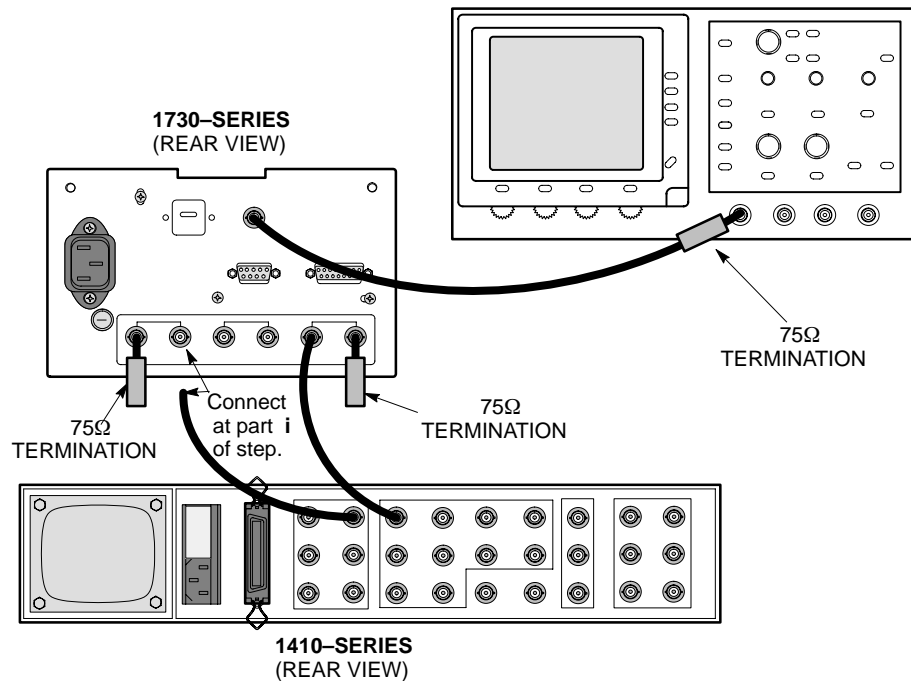

Figure 5-5: Checking PIX MON OUT signal amplitude.

- d. Set the 1730-Series REF switch to EXT.
- e. **CHECK** – that the level at the PIX MON OUT is $0\text{ V} \pm 0.5\text{ V}$.
- f. Turn on the 1730-Series LINE SELECT and set the test oscilloscope sweep rate to display at least one field.
- g. Using the test oscilloscope Magnifier and horizontal position control, display the dc level (intensified) shifted line.
- h. **CHECK** – that the dc level shift for the intensified line is approximately 180 mV.
- i. Connect the color bar signal to the CH-A INPUT.

- j. **CHECK** – that the amplitude of the color bar is within 0.95 to 1.05 V from sync tip to the 100% peak white bar, as displayed on the test oscilloscope. Turn OFF the 1730–Series LINE SELECT.
- k. Disconnect all signal cables from the 1730–Series Waveform Monitor.

12. Check DC Restorer Operation

REQUIREMENT – Attenuation of 60 Hz input signal 20% or less. Blanking level shift with APL change, less than 1 IRE (7 mV). Blanking level shift with presence or absence of burst, less than 1 IRE (7 mV).

- a. Connect a modulated 5–step linearity signal (with AC Bounce on) to the CH–B INPUT, and terminate in 75Ω . Display the signal with the 2H SWEEP. Turn ON FAST DC REST. Position the blanking level of the signal to the 0 IRE (0 V) line.
- b. **CHECK** – that the blanking level does not move when the VARIABLE gain is rotated.
- c. **CHECK** – that the blanking level moves when the DC REST is turned off. Leave DC REST OFF. Turn off variable gain.
- d. Connect the black burst signal to the EXT REF and terminate the remaining side of the loop–through input.
- e. Connect the function generator output through a X10 (75Ω) Attenuator to the CH–A INPUT.
- f. Select CH–A and EXT REF.
- g. Set the function generator frequency to a 60 Hz (50 Hz PAL) sine wave. Set the amplitude for a 100 IRE (700 mV PAL) 1730–Series display.
- h. Turn ON SLOW DC REST.
- i. **CHECK** – that the display amplitude is 80 IRE (560 mV PAL) or greater.
- j. Turn ON FAST DC REST.
- k. **CHECK** – that the display amplitude is 10 IRE (70 mV PAL) or less.
- l. Remove the function generator output and replace it with the linearity signal and terminate the remaining side of the loop–through input.
- m. Select 2LINE SWEEP.
- n. Turn ON SLOW DC REST.

- o. Switch linearity signal APL between 50% and 10% and between 50% and 90%.
- p. **CHECK** – that the signal blanking level moves less than 1 IRE (7 mV).
- q. Connect the multiburst signal to the CH-A INPUT and terminate the remaining side of the loop-through input.
- r. Switch multiburst generator Burst off and on.
- s. **CHECK** – that the blanking level changes less than 1 IRE (7 mV).
- t. Turn OFF DC REST.
- u. Remove the signal cables from the 1730-Series.

13. Check Flat Response

REQUIREMENT – Flat response with 50 kHz as a reference; 250 kHz to 6 MHz within 2%. X5 Flat response with 50 kHz as a reference; 250 kHz to 6 MHz within 5%.

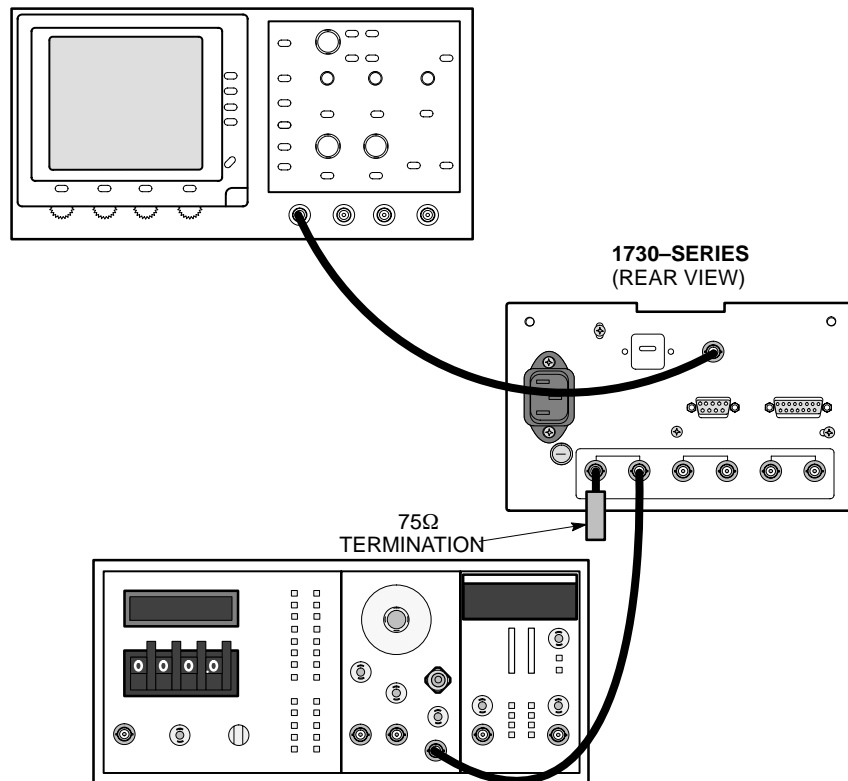

Figure 5-6: Initial equipment setup to check Flat Response.

- a. Connect a 50 Ω precision cable and 50 to 75 Ω minimum loss pad from the leveled sine wave to the CH-A input. Terminate the loop-through in 75 Ω .
- b. Select EXT REF.
- c. Set the leveled sine wave generator to 50 kHz (reference frequency) and set the output amplitude for a 100 IRE (0.7 V) display amplitude.
- d. **CHECK** – the flat response using the 50 kHz response as a reference. Changing the frequency of the sine wave generator, check that the response is within $\pm 2\%$ from 250 kHz to 6 MHz.
- e. Change the 1730-Series VERTICAL GAIN to X5.
- f. Set the leveled sine wave generator to 50 kHz and set the output amplitude for a 100 IRE (0.7 V) display amplitude.
- g. **CHECK** – flat response using the 50 kHz response as a reference. Check that the amplitude is 100 IRE (0.7 V) $\pm 5\%$ from 250 kHz to 6 MHz.
- h. Move leveled sine wave generator output to CH-B and terminate the remaining side of the loop-through INPUT with a 75 Ω termination.
- i. Select CH-B INPUT.
- j. **CHECK** – flat response using the 50 kHz response as a reference. Check that the amplitude is 100 IRE (0.7 V) $\pm 5\%$ from 250 kHz to 6 MHz.
- k. Turn off X5 VERTICAL GAIN.
- l. **CHECK** – the flat response using the 50 kHz response as a reference. Check that the response is within $\pm 2\%$ from 250 kHz to 6 MHz.

14. Check PIX MON OUT Frequency Response

REQUIREMENT – PIX MON OUT Frequency Response with a 50 kHz reference; within 3% from 250 kHz to 6MHz.

- a. Connect a coaxial cable to the + input on the Peak To Peak Detector Amplifier and connect the other end of the cable to the Peak to Peak Detector Head.
- b. Press the + Input button on the Peak To Peak Detector Amplifier.
- c. Adjust the Peak to Peak Detector Amplifier + Input Level control fully clockwise.

- d. Connect the Peak to Peak Detector Head to the 1730–Series PIX MON output.
- e. Connect the Peak to Peak Detector Amplifier Output to the oscilloscope Vertical input.
- f. Set the 1730–Series GAIN to NORMAL and REF to EXT.
- g. Set the sine wave generator to 50 kHz (reference frequency) and adjust the generator amplitude for a 1 Volt display on the 1730 Series.
- h. Set the following controls on the Vertical Input:

Volts/Div.	10 mv
Coupling	dc
- i. Adjust the oscilloscope vertical Position control to place trace on the oscilloscope CRT center line.
- j. Check – that the frequency response is within 30 mV ($\pm 3\%$) of the reference set on the oscilloscope, as the generator frequency is varied from 250 kHz to 6 MHz.

NOTE. Other checks in this procedure assure that frequency response is within specification; however, the low frequency response can be checked using an LF sine wave generator (see sine wave generator in equipment required list) and performing part d. of this step for 50 kHz to 250 kHz.

15. Check Transient Response

REQUIREMENT – Transient response for the 2T pulse and 2T bar: preshoot 1% or less. Pulse–to–bar ratio: 1:1 within 1%. Overshoot: 2% or less. Ringing: 2% or less. Tilt: 1% or less for field–rate square wave or 25 μ s bar. Variation of the 12.5T modulated pulse (20T for PAL) baseline (Overscan), less than 2% as the display is positioned over the middle 80% of the display (with ac–coupled inputs).

- a. Connect the pulse and bar signal to the CH–B INPUT, and terminate the remaining side of the loop–through connector with a 75 Ω termination.
- b. Select the full amplitude 2T pulse and bar signal from the television test signal generator. Display the signal with the 1LINE SWEEP.
- c. **CHECK** – for less than 1% preshoot and less than 2% overshoot and ringing for the pulse and bar transitions.
- d. **CHECK** – for a pulse–to–bar ratio within 1% of unity.
- e. **CHECK** – for less than 1% tilt across the bar.

- f. Select the field square wave signal. Display the signal with the 2FLD SWEEP.
- g. **CHECK** – for less than 1% tilt across the high APL portion of the display.
- h. Set the 1730-Series VERTICAL to X5 gain.
- i. Select 2LINE SWEEP and SWEEP MAG ON.
- j. Display the 12.5T modulated pulse for NTSC and PAL-M (20T for PAL). Position the baseline over the center 140 IRE (1 V).
- k. **CHECK** – that the baseline of the modulated pulse varies less than 2%.

16. Check X5 Transient Response

REQUIREMENT – Transient response for the 2T pulse and 2T bar: preshoot 1% or less. Pulse-to-bar ratio: 1:1 within 2%. Overshoot: 4% or less. Ringing: 4% or less.

- a. Connect the black burst signal to the 1730-Series EXT REF and terminate the remaining side of the loop-through input.
- b. Turn SWEEP MAG OFF. Select X5 VERTICAL GAIN and EXT REF.
- c. Install the Step Attenuator and insert 14 dB of attenuation in the input signal path.
- d. **CHECK** – for 1% or less preshoot and 4% or less overshoot and ringing for the pulse and bar transitions.
- e. **CHECK** – for a pulse-to-bar ratio within 2% of unity.
- f. Disconnect signal from the CH-B INPUT.

17. Check Low Pass Filter Response

REQUIREMENT – Response at 15 kHz does not vary between FLAT and LPASS by more than 1%.

- a. Connect the modulated, 5-step linearity signal to the CH-B INPUT.
- b. Select the 100-IRE (100%) FLAT FIELD/ALT LINEARITY setting of the generator.
- c. Select the 1730-Series LPASS FILTER and turn off X5 GAIN (X1).
- d. Switch between LPASS and FLAT.

- e. **CHECK** – that the amplitude of the linearity signal, in LPASS, is within $\pm 1\%$ of the amplitude of the display in the FLAT mode.

18. Check Chroma Filter Response

REQUIREMENT – Response at 3.58 MHz (4.43 MHz for PAL) does not vary between FLAT and CHROMA by more than 1%. Attenuation at 7.2 MHz (8.9 MHz for PAL): greater than 20 dB.

- a. Connect the color bar signal to the CH–B INPUT and terminate the remaining side of the loop–through input.
- b. Turn the Luminance (Y) portion of the signal off. Unlock the SCH phasing of the generator.
- c. Display the signal in FLAT with the 2LINE SWEEP and INT REF. Use the 1730–Series VARIABLE gain control to adjust the amplitude of the largest Chroma packet to equal the amplitude from blanking to 100% peak white. Switch the FILTER to CHROMA.
- d. **CHECK** – that the amplitude of the largest chrominance bar is 99 to 101% of the amplitude in part b.
- e. Select FLAT filter. Connect the sine wave generator to the CH–B INPUT and set the frequency to 50 kHz. Adjust the amplitude so that the display is 100 IRE (700 mV for PAL).
- f. Set the frequency of the sine wave generator to 7.2 MHz (8.9 MHz for PAL). Select CHROMA filter.
- g. **CHECK** – that less than 10% of the reference amplitude remains.

19. Check Return Loss

REQUIREMENT – Return Loss for INPUT at least 40 dB from 50 kHz to 6 MHz (instrument on or off, any deflection factor setting). Return Loss of the PIX MON OUT at least 30 dB (50 kHz to 6 MHz) with the instrument on.

NOTE. *Return Loss Check:*

The Return Loss Check needs to be done only if repairs have been made on the Input circuitry.

- a. Connect a precision 50 Ω cable from the spectrum analyzer RF Input to the RF Output on the RF Bridge.
- b. Connect a precision 50 Ω cable from the spectrum analyzer TG Output to the RF Input on the RF Bridge.

- c. Select Demod/TG on the spectrum analyzer. Turn on the tracking generator and set the tracking generator fixed level to 0.00 dBm.
- d. Set the spectrum analyzer Span/Div to 1 MHz and the Resolution Bandwidth to 30 kHz.
- e. Set the spectrum analyzer Vertical Scale to 10 dB.
- f. Set the spectrum analyzer Reference Level to the first major division down from the top on the analyzer display.
- g. Remove one of the cables from the RF Bridge.
- h. Set the spectrum analyzer Frequency to 5 MHz and turn the Marker on. Set the Marker to 6 MHz.
- i. Reconnect the cable to the RF Bridge.
- j. **Note** – the Reference Level Readout.
- k. Adjust the spectrum analyzer External Attenuation Amplitude (on the 2712 Input menu) by the amount noted in part j. of this step. Note: The Reference Level Readout should now be 0.00 dBm.
- l. Connect the precision high-frequency terminator to the Device Under Test connector on the RF Bridge.
- m. **Check** – that the frequency response from 0 MHz to 6 MHz is ≥ 40 dBm.
- n. Return the spectrum analyzer frequency marker to 6 MHz if it was moved.
- o. Remove the precision high-frequency terminator from the RF Bridge.
- p. Connect the male-to-male bnc adapter to the Device Under Test connector on the RF Bridge.
- q. Connect the Device Under Test connector on the RF Bridge to the 1730-Series CH-A INPUT. Terminate the CH-A loop-through with the same precision high-frequency terminator used in step o.
- r. Select CH-A INPUT.
- s. **Check** – that the Reference Level Readout on the spectrum analyzer is ≥ 40 dBm with the instrument power on and off.
- t. Repeat parts q. through s. for each Input channel (CH-B and EXT REF).
- u. Remove all cables and terminators from the 1730-Series.

- v. Check that the 1730-Series inputs are not terminated and that there is no signal applied. Connect the Device Under Test connector on the RF Bridge to the PIX MON OUT connector.
- w. **CHECK** – that the return loss of the PIX MON OUT is better than 30 dB (15.8 mV), from 50 kHz to 6 MHz. Make this measurement with instrument power on and no signal output.

End of Performance Check Procedure.

Adjustment Procedure

The Adjustment Procedure covers only adjustments. Checks, other than those that must be made to ensure a step is completed, are in the Performance Check Procedure. There are actually two Adjustment Procedures, the short-form version is provided for those familiar with the adjustments, while the longer (more detailed) procedure is provided for those who need it. Allow 20 minutes of warm-up time, at normal room temperature (approximately 25° C), before making any adjustments to the instrument.

Short-form Procedure

The Short-Form Adjustment Procedure has the adjustment steps in the same order as the longer form of the procedure. Adjustment circuit numbers are also included with the step title. Note also that the Short-Form Procedure can be used as an index for the long-form.

1. Adjust +5 V (R99)
2. Adjust CRT Bias (R58)
3. Adjust Geometry (R45), Focus (R11) and Astigmatism (R49)
4. Adjust Trace Rotation
5. Adjust On-Board Regulated Supplies (R167 and R168)
6. Adjust 2Line and 1 μ s Sweep Calibration (R660 and R552)
7. Adjust 0.2 μ s Sweep Calibration (R553)
8. Adjust Dual Filter Switching Phase (R636)
9. Adjust Magnifier Registration (R661)
10. Adjust RGB Offset (R856)
11. Adjust RGB Compensation (C953)
12. Adjust Output Bias (R489)
13. Adjust Calibration Signal Amplitude (R689)
14. Adjust Dual Input dc Level (R492)
15. Adjust X5 Magnifier Registration (R274)
16. Adjust Channel-A Input Compensation (C195) and Flat Response (L180 and L190)

- 17. Adjust Channel-B Input Compensation (C696)
- 18. Adjust X5 Gain HF Response (C372)
- 19. Adjust Video Out Response (C694)
- 20. Adjust Low Pass Filter (C777 and C775)
- 21. Adjust Chroma Filter (1730-R683, C683, and C783; 1731-R680, C778, and C784; 1735-R680, C778, C784, R683, C683, and C783)
- 22. Adjust Readout Position (R209)
- 23. Adjust CRT Bias (R58) and Line Select Focus (R245)

Standard Adjustment Procedure

The Front-Panel Presets and Signal Connections for initiating the Adjustment Procedure are shown in Fig. 5-13. The correct settings of the front-panel controls to start this procedure are shown in Table 5-3.

Table 5-3. Preliminary Control Settings

POWER	ON
INTENSITY	Set to preference
FOCUS	---
SCALE	---
VERTICAL Position	Set later
HORIZONTAL Position	Set later
FILTER	FLAT
REF	INT
INPUT	B
GAIN (switch)	off
DC REST	OFF
MAG	off
SWEEP	2LINE
FIELD	FLD1
LINE SELECT	off

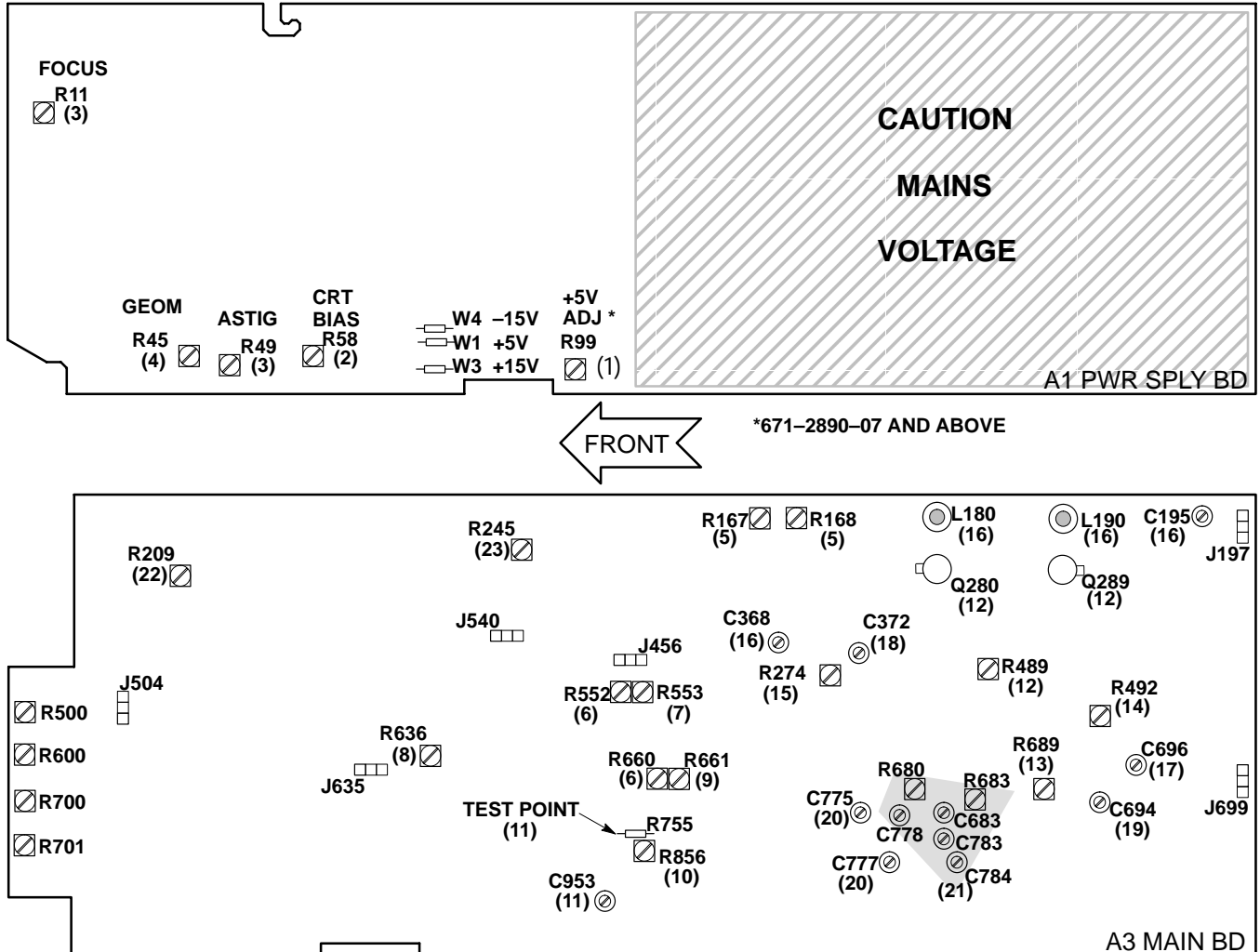

Figure 5-7: Adjustment locations for the Main and Power Supply boards. Numbers in parentheses indicate the step where that adjustment is used.

Preliminary Setup

- a. Connect the 1730-Series ac power cord to the variable autotransformer. Turn power on and set the autotransformer for either 110 or 220 Volts.
- b. Connect the multiburst signal to the CH-B INPUT and terminate the opposite side of the loop-through with a 75Ω termination.

A1 POWER SUPPLY BOARD

1. Adjust +5 V

- a. Connect the DMM negative lead to TP1 (GND) and the positive lead to W1 (+5V).
- b. ADJUST – R99 (+5V ADJ) for $+5.0\text{ V} \pm 0.5\text{V}$.

2. Adjust CRT Bias

- a. Turn the INTENSity control fully counterclockwise.
- b. ADJUST – R58 (CRT BIAS) so that the display is just extinguished.
- c. Set the INTENSity control to desired level.

3. Adjust Geometry, Focus and Astigmatism

- a. Adjust – R45 (GEOM) for $35\text{V} \pm 1\text{V}$ at pin 1 of J3.
- b. Select CH–B INPUT.
- c. Set the FOCUS control on the front panel so that it is approximately at the center of its rotation.
- d. ADJUST – R11 (CENTER FOCUS) and R49 (ASTIG) for the most clearly-defined multiburst display.

4. Adjust Trace Rotation and Geometry

- a. Select CH–A INPUT.
- b. ADJUST – the front-panel TRACE ROT potentiometer for a level trace across the CRT's 0 IRE line (0.3 V line for PAL).

A3 MAIN BOARD

5. Adjust On-Board Regulated Power Supplies

NOTE. The power supply adjustments should not be made unless the entire procedure is going to be performed. If supplies are within tolerances listed below, any individual adjustment should be possible without having to perform a complete readjustment.

- a. Connect the voltmeter ground lead to one of the rear-panel ground lugs and the active lead to the -11.8 V test point. See Fig. 5-8.

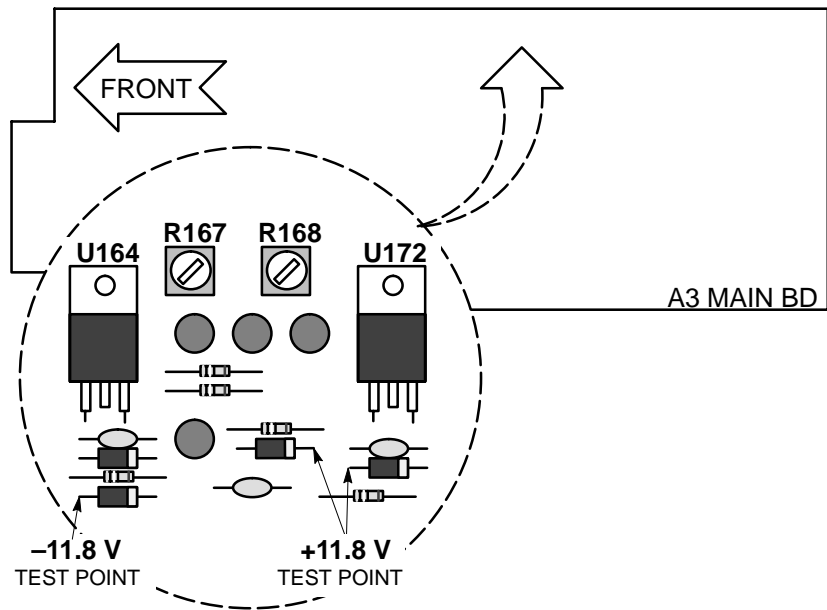

Figure 5-8: Segment of the Main board, showing the test points and adjustment locations for the ± 11.8 V supplies.

- b. **ADJUST** – R167 (-11.8 V ADJ) for -11.78 to -11.82 volts.
 - c. Connect the voltmeter active lead to the $+11.8$ V test point. See Fig. 5-8.
 - d. **ADJUST** – R168 ($+11.8$ V ADJ) for $+11.78$ to $+11.82$ volts.
- 6. Adjust 2Line and 1 μ s Sweep Calibration**
- a. Display the CAL signal on the waveform monitor in the 2LINE SWEEP.
 - b. **ADJUST** – R660 (Sweep Length) for one cycle of the CAL signal per major division over the center 10 divisions.
 - c. Turn on the MAG.
 - d. **ADJUST** – R552 (1 μ s Cal) for one full cycle over the 10 major divisions.
- 7. Adjust 0.2 μ s Sweep Calibration**
- a. Set REF to INT and select CH-A INPUT.

- b. Loop-through connect the multiburst output from the 1410-Series generator to the CH-A INPUT of the 1730-Series and the Digital Counter. See Fig. 5-9.

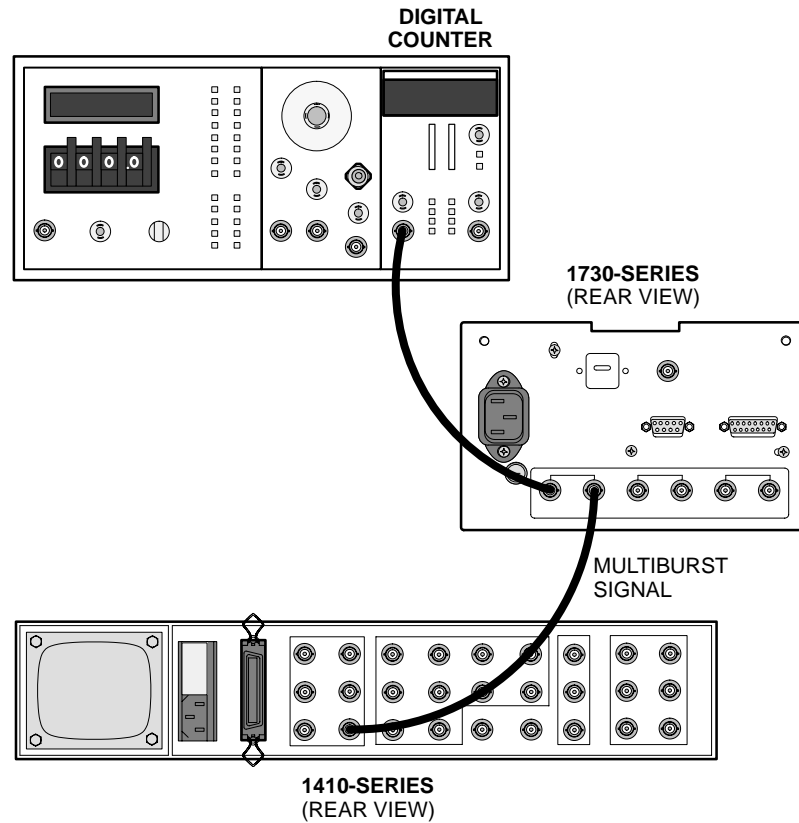

Figure 5-9: Equipment setup to adjust 0.2 μ s timing.

- c. Set the multiburst generator to Low, Continuous, and Manual. Turn Markers off.
- d. Adjust the multiburst Frequency for a 5 MHz sine wave as measured on the Digital Counter.
- e. Select the 1730-Series VAR VERTICAL GAIN and adjust the VAR GAIN control for a display amplitude of approximately 6 divisions.
- f. Change the multiburst generator to Composite.
- g. Select 1LINE SWEEP and MAG.

- h. **ADJUST** – R553 for 10 cycles of subcarrier over 10 divisions ± 1 minor division. Recheck multiburst generator frequency by switching it back to Continuous.
- i. Disconnect the cable that goes to the Digital Counter and terminate the open side of the CH-A input with a 75 Ω end-line terminator.

8. Adjust Dual Filter Switching Phase

- a. Select 2LINE SWEEP and MAG off.
- b. Hold the waveform monitor FILTER button in until both the FLAT and LPASS indicators are lit.
- c. Position the tip of the sync pulse, that occurs between the two lines, so that the switching transition is visible.
- d. **ADJUST** – R636 (Sw. Ph) to placed the switching transition at the center of the sync tip.

9. Adjust Magnifier Registration

- a. Set the multiburst generator for High Range Multiburst.
- b. Turn on the 1730-Series MAG.
- c. Use the HORIZONTAL Position control to position the leading edge of the sync pulse to the center major graticule division.
- d. Turn the waveform monitor MAG off.
- e. **ADJUST** – R661 (MAG REG) so that the leading edge of sync is at the center major graticule division. It may be necessary to repeat this step several times to achieve magnifier registration.
- f. With the MAG off check that both ends of the trace can be positioned to at least the center of the screen.

10. Adjust RGB Offset

- a. Disconnect the multiburst signal and connect the color bar signal.
- b. Set the 1730-Series SWEEP rate to 1LINE.
- c. Set the HORIZONTAL Position control to mid range.
- d. Connect pin 2 of the rear-panel REMOTE socket to ground.
- e. Note that the color bar display compresses to 1/4 to 1/3 of its previous length.

- f. **ADJUST** – R856 (RGB Offset) to center the display at mid screen.

11. Adjust RGB Compensation

- a. Remove the color bar signal from the CH-A INPUT.
- b. Input a 10 V, 2 kHz square-wave signal, from the function generator, to pin 1 (with pin 2 still grounded) of the 1730-Series rear-panel REMOTE connector.
- c. Connect a probe from the test oscilloscope to the junction of R854 and R755. See Fig. 5-7 for locations.
- d. **ADJUST** – C953 (RGB Comp) for best transient response.
- e. Remove the connections from the REMOTE connector.

12. Adjust Output Bias

- a. Set the VERTICAL Position control fully clockwise.
- b. Connect the voltmeter lead to the collector (transistor case) of Q280. See Fig. 5-7.
- c. **ADJUST** – R489 (Limit Cent) for +0.8 V.
- d. Set the VERTICAL Position control fully counterclockwise.
- e. Connect the voltmeter lead to the collector (transistor case) of Q289. See Fig. 5-7.
- f. **CHECK** – that the voltage is +0.8 V. If it is not, repeat parts a. through e. until the collector voltages are balanced at the same dc level.

13. Adjust Calibration Signal Amplitude

- a. Connect the VAC signal to the 1730-Series CH-A INPUT; do not terminate. See Fig. 5-10.

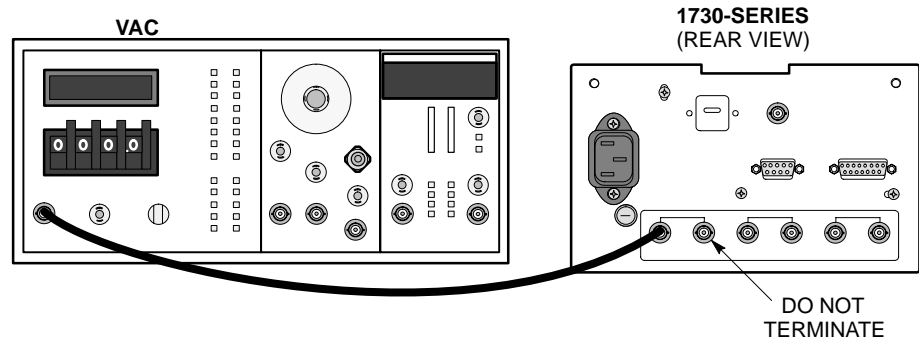

Figure 5-10: Equipment setup for adjusting the calibrator amplitude.

- b. Set the VAC for 999.9 mV.
- c. Adjust the 1730-Series front-panel V CAL so that the VAC signal is displayed as exactly 1 V p-to-p (140 IRE on the NTSC graticule) on the CRT graticule.
- d. Hold the waveform monitor REF button until the CAL signal replaces the function generator signal on the display.
- e. **ADJUST** – R689 (Cal Ampl) so that the Calibrator amplitude is 1 V p-p (140 IRE NTSC) as displayed on the CRT graticule.

14. Adjust Dual Input dc Level

- a. Connect the color bar signal through a 75 Ω in-line terminator and a Dual Input Coupler to the CH-A and CH-B INPUTs. Do not terminate the loop-through inputs.
- b. Connect the black burst signal to the 1730-Series EXT REF and terminate the loop-through input with a 75 Ω in-line terminator.
- c. Set the 1730-Series INPUT to BOTH (CH-A and CH-B).
- d. **ADJUST** – R492 (DC Bal) to overlay the CH-A and CH-B displays.

15. Adjust X5 Magnifier Registration

- a. Select CH-A INPUT and GAIN off (no GAIN LED lit).
- b. Use the VERTICAL Position control to position the signal blanking level on the graticule baseline.

- c. Select X5 GAIN.
- d. **ADJUST** – R274 (X5 Mag) to reposition blanking level to the baseline.
- e. Select GAIN off and repeat parts b, c, and d until there is no baseline shift when switching between off and X5 GAIN.

16. Adjust Channel–A Input Compensation and Flat Response

- a. Connect the multiburst signal through an in-line 75Ω termination to the CH–A INPUT. Connect the black burst signal to the EXT REF and terminate. Connect a 75Ω cable from the 1730-Series PIX MON OUT to the test oscilloscope vertical input (30 MHz vertical plug in). See Fig. 5-11.

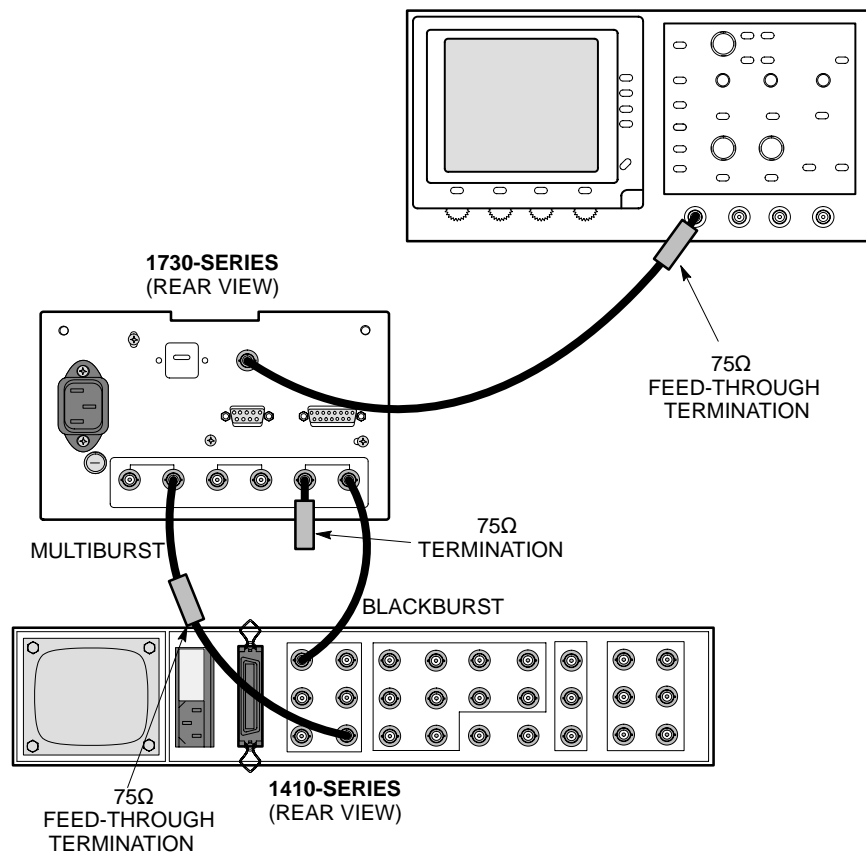

Figure 5-11: Equipment setup for adjusting Channel A input compensation.

- b. Set multiburst generator to Sweep, High Range, Composite, Markers, and Full Amplitude.
- c. Set the 1730-Series SWEEP to 2FLD and EXT REF.
- d. Set the test oscilloscope Vertical Volts/Div to 100 mV.
- e. **ADJUST** – C195 (CH-A Comp.) for flat response at 6 MHz. See Fig. 5-12.

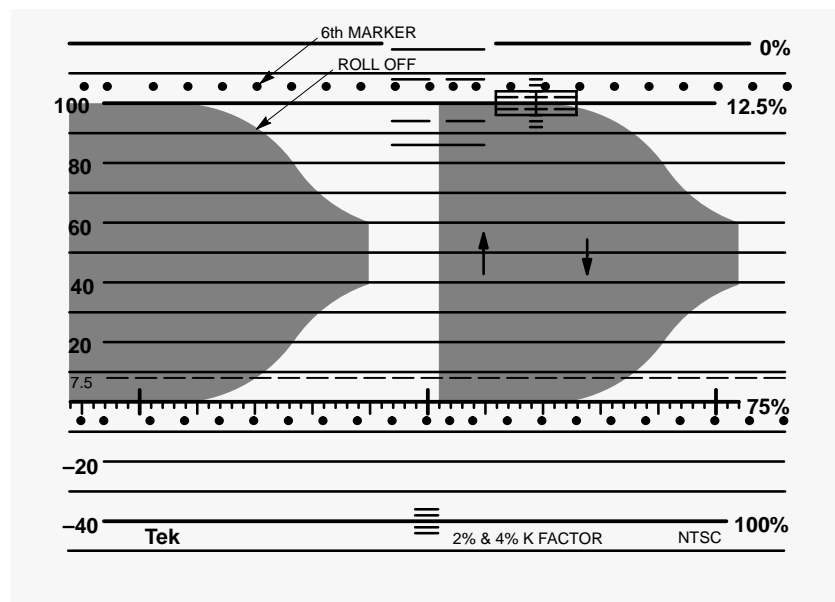

Figure 5-12: Adjusting for best flat response.

- f. Check the response in the 2–4 MHz region. If it is bumped up: **ADJUST** both L180 and L190 in a small amount (both cores should be adjusted together). If it is dipped: **ADJUST** both L180 and L190 out a small amount (both cores should be adjusted together).
- g. Repeat parts e. and f. until the best response to 6 MHz is achieved. C368 (HF Comp) may need to be adjusted slightly (it affects response in the 6–8 MHz region).
- h. Disconnect the multiburst signal from the CH-A INPUT and remove the 75 Ω termination from the remaining side of the loop-through connector.

- i. Connect the output of the leveled sine wave generator to the CH-A and CH-B INPUTS, using a precision 50 Ω cable, a 50–75 Ω minimum loss attenuator, a 75 Ω feed through attenuator, and the dual input coupler.
- j. Set the leveled sine wave generator Frequency to 50 kHz and adjust its Amplitude for a 100 IRE (NTSC or PAL-M) or 700 mV (PAL) output as displayed on the 1730-Series.
- k. Set the leveled sine wave generator Frequency to 6 MHz.
- l. **ADJUST** – C195 (CH-A Comp) for 100 IRE (NTSC and PAL-M) or for 700 mV (PAL).
- m. Set the leveled sine wave generator Frequency to 3.58 MHz (NTSC or PAL-M) or 4.43 (PAL) and check for 100 IRE or 700 mV $\pm 2\%$ (2 IRE or 14 mV). Check both frequencies for the 1735.
- n. If not in specification at 3.58 or 4.43 MHz, repeat parts e. through g. of this step (as set up by parts a. and b.).

17. Adjust Channel-B Input Compensation

- a. Make sure the 1730-Series INPUT is in BOTH (CH-A and CH-B indicators lit).
- b. Select 2LINE SWEEP.
- c. Set the leveled sine wave generator Frequency to 6 MHz.
- d. **ADJUST** – C696 (CH-B Comp) to overlay the CH-A display with the CH-B display.
- e. Set the leveled sine wave generator Frequency to 3.58 MHz (NTSC or PAL-M) or 4.43 (PAL) and check for 100 IRE or 700 mV $\pm 2\%$ (2 IRE or 14 mV). Check both frequencies for the 1735.

18. Adjust X5 Gain HF Response

- a. Select the CH-A INPUT.
- b. Select X5 VERTICAL GAIN.
- c. Set the sine wave generator for 50 kHz.
- d. Select CH-A INPUT, EXT REF, and 1LINE SWEEP.
- e. Adjust the sine wave generator for a displayed amplitude of 100 IRE (or 700 mV).

- f. Set the sine wave generator Frequency to 3.58 MHz (NTSC and PAL-M) or 4.43 MHz (PAL). For dual-standard waveform monitors, make the NTSC adjustment only for this step.
- g. **ADJUST** – C372 (X5 Comp) for an amplitude of 100 IRE (NTSC and PAL-M) or 700 mV (PAL).
- h. Set the sine wave generator frequency to 6 MHz and check that displayed amplitude is still 100 IRE, ± 5 IRE or 700 mV, ± 35 mV.

19. Adjust Video Out Response

- a. Connect the multiburst output to the 1730-Series CH-A INPUT.
- b. Set multiburst for high range and full amplitude.
- c. **ADJUST** – C694 (Pix Mon Res) for flat display (even tops of the first three multiburst packets) on the test oscilloscope. See Fig. 5-13.

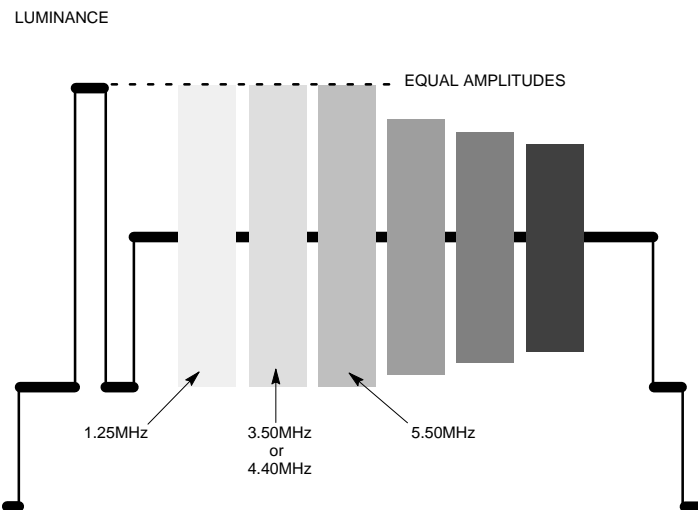

Figure 5-13: Using the high-range multiburst signal to set flatness.

- d. Disconnect the cable from the 1730-Series PIX MON OUT.

20. Adjust Low Pass Filter

- a. Set the 1730-Series SWEEP rate to 2LINE.
- b. Turn off DC REST.
- c. Connect color bar signal to the CH-A INPUT.
- d. Select INPUT A and LPASS FILTER.
- e. Turn on HORIZONTAL MAG and X5 VERTICAL GAIN.
- f. **ADJUST** – C777 (LPASS Filter) for minimum chrominance (minimum trace width on the back porch, following color burst).
- g. Position the sync pulse to the baseline at center screen.
- h. **ADJUST** – C775 (LPASS Filter) for the best corner on the leading edge of the sync pulse.

Perform parts i. through m. for dual-standard waveform monitors only.

- i. Connect the output of the sine wave generator to the 1730-Series CH-A INPUT.
- j. Set the sine wave generator for 50 kHz.
- k. Adjust the sine wave generator for an amplitude, on the 1730-Series, of 100 IRE (700 mV).
- l. Set the sine wave generator Frequency to 4.00 MHz.
- m. Re-adjust C777 for minimum chrominance.

21. Adjust Chroma Filter

- a. Connect a color bar signal to the 1730-Series CH-A INPUT.
- b. Set the color bar generator for Full Field and turn off Luminance (Y) and Setup. Set color bar amplitude to 75%.
- c. Set the 1730-Series to CH-A, FLAT FILTER, 1LINE SWEEP, DC REST OFF, VERTICAL GAIN VAR, and SWEEP MAG off.
- d. Use the 1730-Series VAR to set the displayed amplitude of the largest color bar packet to be from blanking level to peak white (100 IRE for NTSC and PAL-M, or 700 mV for PAL).
- e. Change 1730-Series FILTER to CHRM.
- f. **ADJUST** – R683 (NTSC and PAL-M Chroma Filter Gain) or R680 (PAL Chroma Filter Gain) so that the amplitude of the largest color packet is again 100 IRE or 700 mV, depending on the color standard

employed. For dual-standard waveform monitors, make both the NTSC and PAL adjustments, using the appropriate signal generator.

- g.** **ADJUST** – C683 (3.58 NTSC and PAL–M) or C778 (4.43 PAL) for the squarest envelope (minimum burst envelope decay time). It may be necessary to readjust C783 (NTSC or PAL–M) or C784 (PAL) for maximum amplitude. For dual-standard waveform monitors, make both adjustments, using the appropriate signal generator.
- h.** It may be necessary to perform parts f. and g. several times before reaching the optimum setting for both Gain and Chroma Filter Compensation.
- i.** Turn off VAR GAIN
- j.** Turn on Color Bar Luminance.

22. Adjust Readout Position

- a.** Select FLAT FILTER and 2LINE SWEEP for the 1730-Series.
- b.** Set the 1730-Series FOCUS control for optimum display definition.
- c.** Select LINE SELECT ON and LINE 19 (CRT readout).
- d.** Set the front panel Readout to midrange.
- e.** Position the display to overlay the waveform blanking level on the CRT blanking level line, and position the center sync pulse on the sync amplitude measurement scale.
- f.** **ADJUST** – R209 (Y-Axis Position) so that the 19 in the readout is just above the peak white graticule line (110 IRE or 1.10 V).
- g.** Turn off the Line Select.

23. Adjust CRT Bias and Line Select Focus

- a.** Turn the INTENSity control fully counterclockwise.
- b.** **ADJUST** — A1R58 (CRT Bias) until the display just disappears.
- c.** Turn LINE SELECT ON, line 19.
- d.** Adjust the front panel INTENSity control fully clockwise.

- e. **ADJUST** — A3R245 (LS Focus) for the optimum display definition.
- f. **ADJUST** – the front panel READOUT screwdriver adjustment to match the readout intensity to the Display Intensity.
- g. Turn LINE SELECT Off.

End of Adjustment Procedure.



Maintenance

Section 6 Maintenance

This section contains instructions for preventive maintenance, general troubleshooting, Serial Port and LED Driver diagnostics, and corrective maintenance. If the instrument does not function properly, troubleshooting and corrective measures should be taken immediately to circumvent additional problems.

Preventive Maintenance

Preventive maintenance consists of cleaning, visual inspection, performance checking, and, if needed, readjustment. The preventive maintenance schedule established for the instrument should be based on the environment in which it is operated and the amount of use. Under average conditions, scheduled preventive maintenance should be performed every 2000 hours of operation.

Cleaning

NOTE. *Cleaning Rosin:*

A 2% RMA flux content solder is recommended for making repairs in this instrument. Cleaning of rosin residue is not recommended. Most cleaning solvents tend to reactivate the rosin and spread it under components where it may cause corrosion under humid conditions. The rosin residue, if left alone, does not exhibit these corrosive properties.

The instrument should be cleaned often enough to prevent dust or dirt from accumulating. Dirt acts as a thermal insulating blanket that prevents effective heat dissipation, and can provide high-resistance electrical leakage paths between conductors or components in a humid environment.

Exterior. Clean the dust from the outside of the instrument by wiping with a soft cloth or small brush. A brush is especially useful to remove dust from around the selector buttons, knobs, and connectors. Hardened dirt may be removed with a cloth dampened in water that contains a mild detergent. Abrasive cleaners should not be used.

CRT. Clean the CRT protective shield, light filter, and CRT face with a soft, lint-free cloth dampened in denatured alcohol.

Interior. Clean the interior of the instrument by loosening the accumulated dust with a dry, soft brush. Once the dirt is loosened remove it with low-pressure air

(high-velocity air can damage some parts). Hardened dirt or grease may be removed with a cotton-tipped applicator dampened with a solution of mild detergent and water. Abrasive cleaners should not be used. If the circuit board assemblies must be removed for cleaning, follow the instructions for removal/replacement under the heading of Corrective Maintenance.

After cleaning, allow the interior to thoroughly dry before applying power to the instrument.



CAUTION. *Cleaning fluids:*

Do not allow water to get inside any enclosed assembly or component. Do not clean any plastic materials with organic cleaning solvents, such as benzene, toluene, xylene, acetone, or similar compounds, because they may damage the plastic.

Visual Inspection

After cleaning, carefully check the instrument for defective connections, damaged parts, and improperly seated transistors or integrated circuits. The remedy for most visible defects is obvious; however, if heat-damaged parts are discovered, determine the cause of overheating before replacing the damaged part, to prevent additional damage.

Periodic checks of the transistors and integrated circuits are not recommended. The best measure of performance is the actual operation of the component in the circuit.

Static-Sensitive Components

This instrument contains electrical components that are susceptible to damage from static discharge. Static voltages 1 kV to 30 kV are common in unprotected environments. Table 6-1 shows the relative static discharge susceptibility of various semiconductor classes.

Table 6-1: Static Susceptibility

Relative Susceptibility Levels		Voltage
2	ECL	200V - 500V
3	SCHOTTKY SIGNAL DIODES	250 V
4	SCHOTTKY TTL	500 V
5	HF BIPOLAR TRANSISTORS	400 to 600 V
6	JFETS	600 to 800 V
7	LINEAR μ CIRCUITS	400 to 1000 V est.

Table 6–1: (Cont.)Static Susceptibility

Relative Susceptibility Levels		Voltage
8	LOW POWER SCHOTT-KY TTL	900 V
9	TTL	1200 V

Observe the following precautions to avoid damage:

1. Minimize handling of static-sensitive components.
2. Transport and store static-sensitive components or assemblies in their original containers, on a metal rail, or on conductive foam. Label any package that contains static-sensitive components or assemblies.
3. Discharge the static voltage from your body, by wearing a wrist grounding strap, while handling these components. Servicing static-sensitive assemblies or components should be done only at a static-free work station by qualified personnel.
4. Nothing capable of generating or holding a static charge should be allowed on the work station surface.
5. Keep the component leads shorted together whenever possible.
6. Pick up the components by the body, never by the leads.
7. Do not slide the components over any surface.
8. Avoid handling components in areas that have a floor or work surface covering capable of generating a static charge.
9. Use a soldering iron that is connected to earth ground.
10. Use only special antistatic, suction, or wick-type desoldering tools.

Performance Checks and Readjustments

Instrument performance should be checked after each 2000 hours of operation, or every 12 months, if used intermittently. This will help to ensure maximum performance and assist in locating defects that may not be apparent during regular operation. The Performance Check Procedure and the Adjustment Procedure are in Section 5.

Troubleshooting

The material contained here is general and is not intended to cover specific cases. Note that the manual itself is considered a troubleshooting aid, and as such a brief discussion of its content is in order.

The procedural information that appears as General Troubleshooting Techniques should be familiar to most technicians; however, a quick review may save some time and reduce “wheel spinning.”

Foldout Pages

The foldout pages at the back of the manual contain information that is useful in troubleshooting the instrument. Block and schematic diagrams, circuit board illustrations, and parts locating charts are found there.

Diagrams. Schematic diagrams are the most often used troubleshooting aids. The circuit number and electrical value of each component is shown on the diagram. The first tabbed page has definitions of the symbology used on the schematic diagrams. Refer to the Replaceable Electrical Parts list for a complete description of each component. Circuits that are mounted on circuit boards or assemblies are enclosed in a border, with the name and assembly number shown on the border.

NOTE. *Change Information:*

Check the Change Information section in the rear of the manual for corrections and modifications to the instrument and the manual.

Circuit Board Illustrations. Electrical components, connectors, and test points are identified on circuit board illustrations, which are located on the page facing the first schematic diagram for that board. Circuit board illustrations are assigned location grids along the left side and top, which are used with the parts locating charts to rapidly locate the components.

Parts Locating Charts. The parts locating charts are used in conjunction with the location grids on the board illustrations and on the schematics. There is one locator chart that shows all of the parts on the board. This locator chart shows which schematic the part is shown on, in addition to the board and schematic grid locations for that part. In addition, there are locator charts facing each schematic page that gives the board and schematic grid locations lists for only the parts depicted on that schematic page.

Assembly and Circuit Numbering. The circuit board assemblies are assigned assembly numbers. Figure. 6-1 shows the circuit board assembly locations for this instrument.

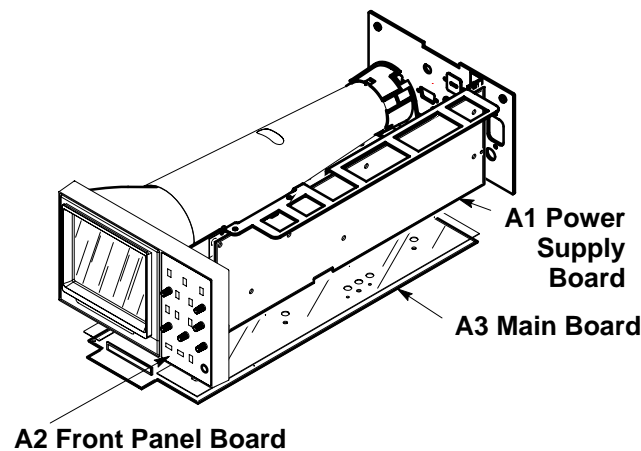

Figure 6-1: Circuit board assembly locations.

Adjustment Locations. Section 5 has illustrations that have the adjustments and test points called out as calibration and troubleshooting aids.

Parts Lists

There are two separate parts lists in this manual. The Replaceable Electrical Parts list (Section 8) precedes the schematic diagrams and circuit board illustrations. The Replaceable Mechanical Parts list (Section 10), accompanied by exploded view drawings, follows the schematic diagrams and circuit board illustrations.

Replaceable Electrical Parts. This list is arranged by assembly as designated in ANSI Standard Y32.16–1975. The list begins with the part numbers for the major assemblies (etched circuit boards). Each circuit board is identified by an A# (Assembly Number).

The circuit numbers of the individual components in the parts list are made up by combining the assembly number with the individual circuit number.

EXAMPLE: R117 on Assembly (circuit board) A3 would be listed in the Replaceable Electrical Parts list as A3R117.

NOTE. *Check Parts Lists:*

Always consult the parts list for part numbers and descriptions when ordering replacement parts. Some parts may have been replaced or have a different part number in an individual instrument. Also check the “Change Information” at the back of the manual for the most recent changes.

Replaceable Mechanical Parts. This list is arranged so that it corresponds to the exploded view drawing for major instrument components. The list and

exploded view drawing comprise Section 10 of this manual. Standard Accessories, which are also included in the parts list, are also in the exploded view drawing.

Major Assembly Interconnection

Signals and power supply voltages are passed through the instrument with a system of interconnecting cables. The connector holders, on these cables, have numbers that identify terminal connectors; numerals are used from pin 2 up. A triangular key symbol is used to identify pin 1 on the circuit board to assist in aligning connector with correct square pins. Fig. 6-2 shows the numbering scheme (and the triangular marking) on the etched circuit board.

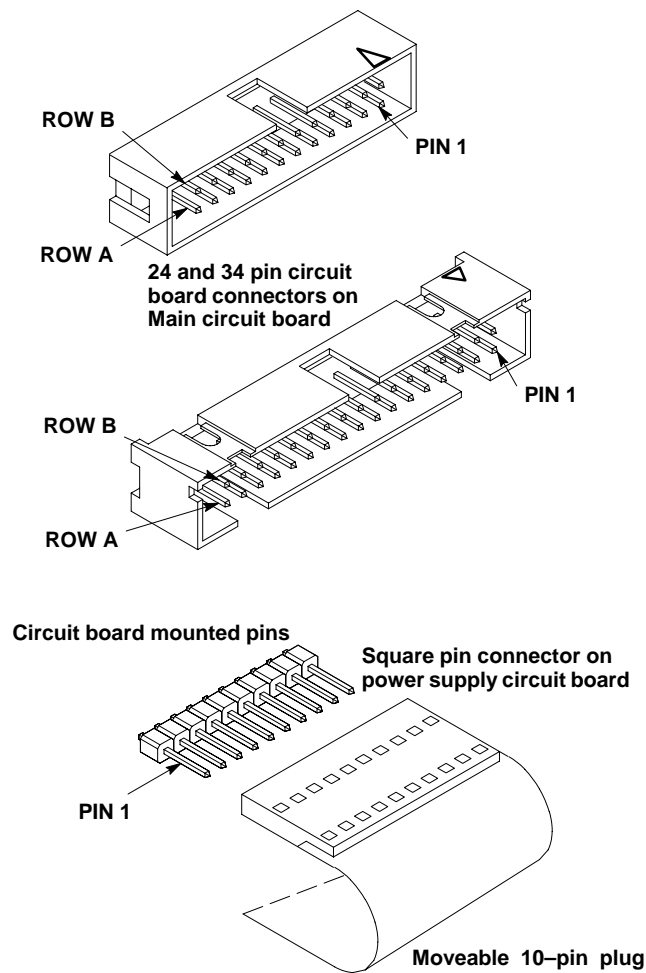

Figure 6-2: Multiple pin connectors used in the 1730-Series Waveform Monitor.

General Troubleshooting Techniques

The following procedure is designed to assist in isolating problems, which in turn expedites repairs and minimizes down time.

1. Ensure that the malfunction exists in the instrument. This is done by making sure that the instrument is operating as intended by Tektronix (see Operating Instructions in Section 2), and by checking that a malfunction has not occurred up stream from the waveform monitor.
2. Determine and evaluate all trouble symptoms. This is accomplished by isolating the problem to a general area such as an assembly. The block diagram is a valuable aid in signal tracing and circuit isolation.



CAUTION. Probes and Meter Leads:

Use extreme care when probing with meter leads or probes, because of the high component density and limited access within the instrument. The inadvertent movement of leads or a probe could cause a short circuit or transient voltages capable of destroying components.

3. Determine the nature of the problem. Attempt to make the determination of whether the instrument is out of calibration or if there has been a component failure. Once the type of failure has been determined, proceed on to identify the functional area most likely at fault.
4. Visually inspect the suspect assembly for obvious defects. Most commonly these will be broken or loose components, improperly seated components, overheated or burned components, chafed insulation, etc. Repair or replace all obvious defects. In the case of overheated components, determine the cause of overheating and correct the cause before re-applying power.
5. Use successive electrical checks to locate the source of the problem. The primary tool for problem isolation is the oscilloscope. Use the Performance Check Procedure (located in Section 5) to determine if a circuit is operating within specifications. At times it may be necessary to change a calibration adjustment to determine if a circuit is operational, but since this can destroy instrument calibration, care should be exercised. Before changing an adjustment, note its position so that it can be returned to its original setting.
6. Determine the extent of the repair. If the necessary repair is complex, it may be advisable to contact your local Tektronix field office or representative before continuing. If the repair is minor, such as replacing a component, see the parts list for replacement information. Removal and replacement procedures for the assemblies can be found under Corrective Maintenance.



CAUTION. *Removing Components:*

Always remove the assembly from the instrument prior to attempting to replace a soldered in component. See Corrective Maintenance for the correct procedure.

Specific Troubleshooting Techniques

The 1730–Series Waveform Monitor has two areas where ordinary troubleshooting techniques do not apply.

This instrument contains internal diagnostics for the serial port and the front–panel LED indicators. Specific instructions for these diagnostics follow the Power Supply troubleshooting procedure.

Power Supply

The power supply is of the high–efficiency type and requires a specific troubleshooting procedure and an isolation transformer to avoid personal danger or instrument damage.

The 1730–Series power supply presents special troubleshooting problems, if a fault occurs. Besides having a sizeable area where dangerous potentials can be contacted, the type of circuitry employed can not be trouble shot by conventional means.



WARNING. *Read Instructions:*

Do not attempt to troubleshoot the 1730–Series power supply without reading these instructions.

Troubleshooting Procedure

NOTE. *Read Theory of Operation:*

A review of the power supply Theory of Operation is recommended before attempting repairs.

The equipment needed to troubleshoot the power supply:

- Digital Multimeter (DMM), with a diode check function
- Oscilloscope
- 0 to 20 VDC Variable Power Supply

- Clip Lead – to short across a component
- High Voltage Probe, $\geq 1 \text{ G}\Omega$ input resistance

Introduction

The Troubleshooting Procedure for the Power Supply (Assembly A1) is split into two sections, the Low Volts and High Volts Supplies. Start the procedure by determining which section of the power supply the problem is in. Apply ac power and turn on the power supply. From Table 6–2, determine which symptom the power supply exhibits and refer to the corresponding procedure.

Table 6–2: Power Supply Fault Symptoms

Symptom	Procedure
Line fuse open	Rectifier/Switcher Check (Low Volts)
Power Supply cycles OFF/ON	Output Check (Low Volts) or High Voltage Oscillator Check (High Volts)
Does not power up	Control Circuit Check (Low Volts)
+5 V not regulating	Error Amplifier Check (Low Volts)
Improper CRT display	High Volts Supply

Low Volts Supply

NOTE. *Low Volts Supply Load:*

A 20 Ω , 2 watt resistor should be used as a load for the Low Volts Supply. Disconnect J4 and connect the 20 Ω resistor between W1 (+5 V) and TP1 (secondary ground).

1. Preliminary Checks

- a. A properly functioning and loaded Low Volts supply will output the voltages listed in Table 6–3. Use the DMM to measure the voltages between TP1 and the voltage test points. If the supply is not regulating properly, continue with the procedure.

Table 6–3: Low Volts Supply Voltages

Test Point	Voltage Range
W1 – (+5 V)	+4.88 to +5.12 V
W4 – (+15 V)	+14.0 to +16.0 V

Table 6–3: (Cont.) Low Volts Supply Voltages

Test Point	Voltage Range
W3 – (–15 V)	–14.0 to –16.0 V
W2 – (+40 V)	+39.0 to +41.0 V

NOTE. *Low Volts Supply Power Connection:*

The Low Volts power supply troubleshooting is performed without applying ac power.

- b. Disconnect ac power from the instrument. Disconnect the instrument from the Power Supply by removing the jumper from J4.
- c. Use the digital multimeter to measure the voltage between TP2 and the tab (drain) of Q9. Check that the voltage is near 0 V.



CAUTION. *Dangerous Voltages:*

Do not proceed until the the drain of Q9 is near 0 V. Dangerous voltage potentials are present in the circuit until the capacitors discharge.

2. Rectifier/Switcher Check

- a. Use the digital multimeter to measure the voltage between TP2 and the tab (drain) of Q9. Be sure the voltage is near 0 V before proceeding.
- b. Unsolder and lift one end of R102.
- c. With the negative lead of the digital multimeter connected to TP2 and the positive lead connected to the tab of Q9, measure the circuit resistance. A resistance of less than 20 k Ω indicates a shorted mosfet (Q9). If the mosfet is shorted, replace it and perform the Control Circuit Check.
- d. Using the digital multimeter diode test function, test CR21, CR22, CR23, and CR24 for shorts. Diode replacements must be fast reverse recovery (300 ns) types to reduce conducted noise.
- e. Reconnect the lifted end of R102.

3. Output Check

- a. Connect the negative output from the 20 V DC Power Supply to TP1. Connect the positive output to W4 (+15 V). The circuit should draw less

than 20 mA. Excessive current draw can be caused by CR11 or U2 (High Volts power supply).

- b. Connect the negative output from the 20 V DC Power Supply to TP1. Connect the positive output to W2 (+40 V). The circuit should draw less than 20 mA. Excessive current draw can be caused by CR14 or Q6 (High Volts power supply).
- c. Connect the positive output from the 20 V DC Power Supply to TP1. Connect the negative output to W3 (–15 V). The circuit should draw less than 20 mA. Excessive current draw can be caused by CR12.
- d. Connect the negative output from the 5 V DC Power Supply to TP1. Connect the positive output to W1 (+5 V). The circuit should draw less than 20 mA. Excessive current draw can be caused by CR13 or Q1 and Q2 (High Volts power supply).

4. Control Circuit Check

- a. Connect the negative output from the 20 V DC Power Supply to TP2. Connect the positive output to the cathode of CR17. Short C47 with a clip lead. Connect the oscilloscope probe ground to TP2.
- b. Table 6–4 lists the signal present in a properly functioning control circuit.

Table 6–4: Control Circuit Test Points

Circuit Location	Signal
U5, pin 1	Approximately 5 VDC
U5, pin 2	Approximately 2 VDC
U5, pin 3	0 V
U5, pin 4	80 kHz triangle wave, 2 V p-p
U5, pin 6	80 kHz square wave, 18 V p-p
U3, pin 1	80 kHz square wave, 5 V p-p
U3, pin 2	2.1 VDC
U3, pin 6	2.9 VDC
U3, pin 7	Approximately 5 VDC
U4, pin 13	80 kHz repetition rate, 300 ns width, approximately 3 V p-p
Q8, collector	80 kHz repetition rate, 400 ns width, switching from 5 V to approximately 2 V

- c. Remove the clip lead from across C47.

5. Error Amplifier Check

- a. Connect the negative output from the variable DC power supply to TP1. Connect the positive output to W1 (+5 V).
- b. Connect the negative output of another variable DC power supply to TP1. Connect the positive output to W4 (+15 V). Set the variable power supply to 20 VDC.
- c. Connect the digital multimeter between TP1 and the cathode of CR15.
- d. Set the variable DC power supply connected to W1 (+5 V) to 4.8 V. The cathode of CR15 should be approximately 20 V.
- e. Set the variable DC power supply connected to W1 (+5 V) to 5.2 V. The cathode of CR15 should be approximately 2 V.
- f. If this check did not reveal the cause for the +5 V supply not regulating, refer to the Output Check and the Control Circuit Check.

High Volts Supply

1. Preliminary Checks

- a. Table 6–5 lists the High Volts Supply fault symptoms and procedures.

Table 6–5: High Volts Supply Fault Symptoms

Symptom	Procedure
Unable to focus CRT using the front-panel control	Focus Amplifier Check
Unable to adjust CRT intensity using the front-panel control	Z-Axis Amplifier Check Grid Drive Check
No CRT display	High Voltage Oscillator Check CRT Voltage Check

- b. Load the Low Volts Supply with the instrument, or with the 20Ω resistor as detailed at the beginning of the Troubleshooting Procedure.

2. Focus Amplifier Check

- a. Unsolder and lift one end of R24.
- b. Power up the power supply.

- c. Using the digital multimeter, measure the voltage between TP1 and the collector of Q1. It should be approximately -140 V .
- d. Reconnect the lifted end of R24.

3. Z-Axis Amplifier Check

- a. Unsolder and lift one end of R8.
- b. Power up the power supply.
- c. Using the digital multimeter, measure the voltage between TP1 and the collector of Q4. It should be approximately $+10\text{ V}$.
- d. Short together the base and emitter of Q5. The collector of Q4 should be approximately $+100\text{ V}$.
- e. Reconnect the lifted end of R8.

4. Grid Drive Check

- a. Turn off the power supply. Use the diode check on the digital multimeter to test CR1, CR2, CR3, CR5, and CR6 for shorts.
- b. Power up the power supply.
- c. Using the digital multimeter, measure the voltage between TP1 and the cathode of CR5. It should vary between approximately $+75$ and $+200\text{ V}$ as R58 (CRT Bias) is adjusted.
- d. Connect the oscilloscope probe to the anode of CR5 and the probe ground to TP1. The signal should be a clipped sine wave of $+75$ to $+200\text{ V p-p}$.

5. High Voltage Oscillator Check

- a. Connect the oscilloscope probe to T1 pin 3 (Q6 collector) and the probe ground to TP1. Power up the supply. The signal should be a $+60\text{ V p-p}$, 22 kHz sine wave.
- b. Check the voltages listed in Table 6–6 using the digital multimeter:

Table 6–6: High Voltage Oscillator Test Points

Circuit Location	Voltage
T1, pin 4	Approximately $+40\text{ V}$
T1, pin 13	Less than $+2\text{ V}$

Table 6–6: (Cont.)High Voltage Oscillator Test Points

Circuit Location	Voltage
U2, pin 2	Approximately +4.8 V
U2, pin 6	+4 to +11 V
CR9, cathode	Approximately +100 V

6. CRT Voltage Check

NOTE. High Voltage Probe:

This check requires a high voltage probe having an input resistance of 1 G Ω or more.

- a. Connect the high voltage probe ground to TP1.
- b. Load the Low Volts supply with the instrument, or with a 20 Ω , 2 watt resistor loading the 5 V supply.
- c. Power up the power supply.
- d. Use the high voltage probe to measure the voltage at the anode of CR4. It should be approximately –2350 V.
- e. Measure the voltage at the anode end of CR3. It should be 50–150 V more negative than the reading from the anode of CR4.

Serial Port and LED Driver Diagnostics

A non–destructive diagnostic program is built into the 1730–Series. All that is required to perform these diagnostics is a male, 9–pin, sub–miniature D–type connector with pins 8 and 9 connected together. The procedure contained here will isolate non–operating front–panel indicators and open or shorted receive and transmit lines in the serial interface.

1. Turn off instrument POWER.
2. Install the male, sub–miniature D–type connector on the rear–panel AUXILIARY connector.
3. Hold in the LINE SELECT and POWER switches until all front–panel indicators light. This step checks:
 - a. LEDs and LED Drivers
 - b. Interface continuity (RXD in and TXD out)

When all indicators are lit there is continuity from the Microprocessor, out through the TXD Buffer, and back through the RXD Buffer. If all front–pan-

el indicators do not light, check indicator or Driver. If indicators blink, check RXD Buffer (U809B) or TXD Buffer (U809C).

4. Remove the male connector from the rear-panel AUXILIARY connector and check for blinking indicators. This step checks for shorted RXD and TXD lines.

If lights remain on, the RXD and TXD lines are shorted together.

5. Turn off POWER. This ends the Diagnostic Procedure. When the 1730-Series is powered up again it will be operating in the normal waveform monitor configuration.

Corrective Maintenance

NOTE. Warranty Repairs:

No repair should be attempted during the warranty period.

NOTE. Solder:

A 2% RMA flux content solder is recommended for making repairs in this instrument. Cleaning of rosin residue is not recommended. Most cleaning solvents tend to reactivate the rosin and spread it under components where it may cause corrosion under humid conditions. The rosin residue, if left alone, does not exhibit these corrosive properties.

Obtaining Replacement Parts

Replacement parts are available through the local Tektronix field office or representative. However, many common electronic parts are available through local sources. Using a local source, where possible, will eliminate shipping delays.

Changes to Tektronix instruments are sometimes made to accommodate improved components, as they become available, and to improve circuit performance. Therefore, it is important to include the following information when ordering parts:

1. Part Number
2. Instrument Type or Number
3. Serial Number

4. Modification or Option Number (if applicable)

If a part has been replaced with a new or improved part, the new part will be shipped (if it is a direct replacement). If not directly replaceable the local Tektronix field office or representative will contact the customer concerning any changes. After any repair, circuit readjustment may be required.

Mechanical Disassembly/Assembly

The instructions contained here are for disassembly. Re-assembly is performed by reversing the order of the steps used to disassemble the instrument.



WARNING. *Unplug Power Cord:*

Before attempting any disassembly of the instrument be sure to disconnect the power cord.



CAUTION. *Rear Panel Screws:*

Do not re-insert screws in the rear panel when the instrument is removed from the cabinet.

NOTE. *Screw Types:*

All screws, unless otherwise noted, are TORX® screws and can be removed with a T15 screwdriver tip (Tektronix part number 003–0966–00). The exception is #2 Pozidrive® screws which can be removed with a #1 Pozidrive® tip (003–0443–00).

Bezel Removal

1. Remove the two bezel screws. See Figure. 6-3.
2. Grasping the bottom of the bezel, pull straight out and upward. There are two hinges at the top of the bezel that hold it in place; once the bezel is at an approximate 45° angle with the front panel they will disengage.
3. To replace, reverse the procedure.

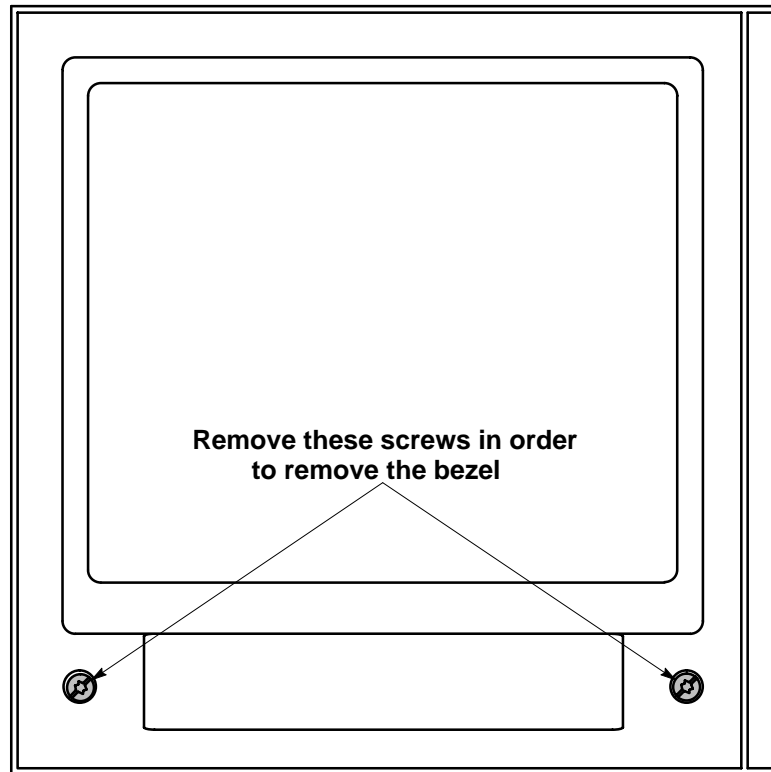

Figure 6-3: Bezel removal.

Graticule Light Removal and Replacement

For graticule light removal and replacement, tweezers with curved, serrated tips are recommended. For example, Miltex PL312,6-100 (equivalent to PL312) or PL317 (longer than PL312).



CAUTION. *Bulb Removal:*

Needle-nosed pliers are not recommended.

Replacement bulbs are supplied with this instrument as Standard Accessories. Additional bulbs can be purchased from Tektronix (see Replaceable Electrical Parts list) or from local electronics distribution sources.

Procedure

1. Remove the bezel according to the preceding instructions.
2. To remove a bulb, position the tweezer tips on the thin, flat portion of the bulb (close to the plastic socket). Carefully pull the bulb straight out.

3. To install a bulb, hold it with the tweezers as described in step 2, position it in front of the socket, and push the bulb with your finger until it snaps into place.
4. Replace the bezel.

CRT Removal

1. Remove the bezel.



WARNING. *The CRT may retain a dangerous charge. Ground the conductor of the anode to discharge the CRT. Do not allow the conductor to touch your body or any circuitry.*

2. Slide a screwdriver with an insulated handle under the anode cap on the side of the CRT, and ground the anode to the chassis, to discharge the CRT. DO NOT touch the metal shaft of the screwdriver while doing this. Disconnect the anode cap by prying it gently away from the CRT.
3. Disconnect J225 (trace rotation) on the Main board and push the connector through the hole in the board.
4. The CRT can now be pulled straight out (some pressure may be needed). The CRT shield, along with the grommet around its front and the rubber manchet around its back, should come out with the CRT.

CRT Replacment

1. If the CRT is to be replaced, remove the metal shield from the neck of the old CRT and place it around the neck of the new CRT, with the WARNING sticker towards the top of the instrument. This should place the opening in the grommet on the front edge of the shield towards the bottom of the instrument. Ensure that the rubber manchet is on the back edge of the shield.
2. Slip the CRT part way back into position and feed the trace rotation wires (and plug) back through the hole in the Main board.



WARNING. *The CRT may retain a dangerous charge. Ground the the anode connector to discharge the CRT. Do not allow the conductor to touch your body or any circuitry.*

3. Use a screwdriver to ground the anode connector on the CRT to the chassis.
4. Slide the CRT into the instrument, guiding the rubber manchet on the end of the shield into the rear CRT support.
5. Align the socket on the A10 CRT Socket board with the pins and key on the CRT. Gently push the CRT and the socket board together until the CRT pins are fully seated in the socket.

6. Replace the trace rotation connector (J225, Main board), and snap the anode lead onto the anode connector on the side of the CRT.
7. Wipe the faceplate of the CRT to remove fingerprints, then replace the bezel. If the fit is too tight to allow the bezel to go into position, or if the CRT has a loose fit after the bezel is completely tightened down, then the rear CRT support must be repositioned.

To reposition the rear CRT support, loosen the two nuts that hold the support in place. With the CRT and bezel in place, push the support towards the front of the instrument until it is snug against the rubber manchet on the rear of the CRT shield. Tighten the two support nuts.

Removing the Rear Panel

1. Remove the five rear screws. See Fig. 6-4.
2. Unsolder the six bnc's and one ground connection. (If 1700F10 Field Upgrade is installed, unsolder leads from the battery connector.)
3. Pull the rear panel free from the chassis; be careful not to pull the unsoldered wires.
4. To replace, reverse the procedure.

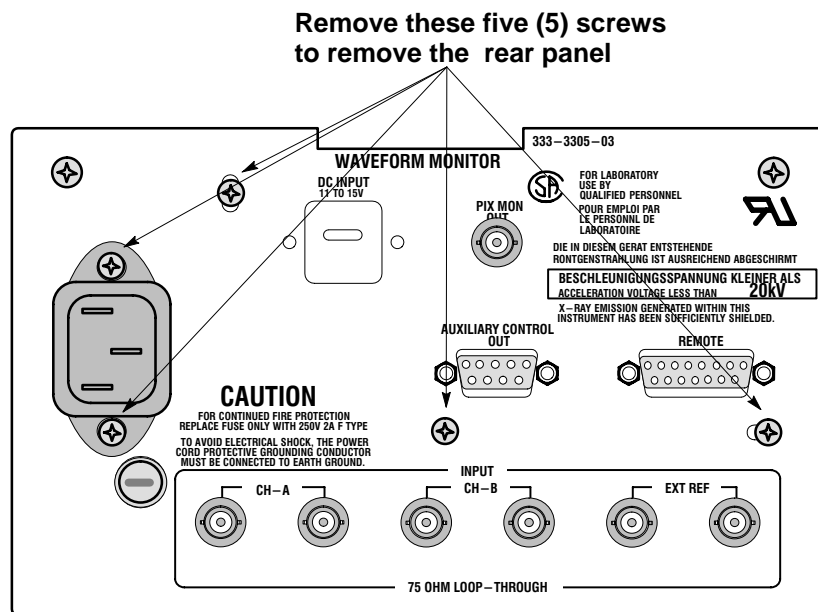

Figure 6-4: Rear panel securing screws.

Removing the Front Panel and the Front Panel Circuit Board

1. Remove the blue multi-wire connector from J154.
2. Remove the two screws holding the board in place. See Fig. 6-5 for location.

3. Remove the board by slipping it through the front-panel opening.

4. To access the Front Panel board components:
 - a. Remove the knobs from the front.
 - b. Remove the four screws from the rear.
 - c. The board should now separate from the front panel making the components accessible.
5. To re-assemble, reverse the procedure.

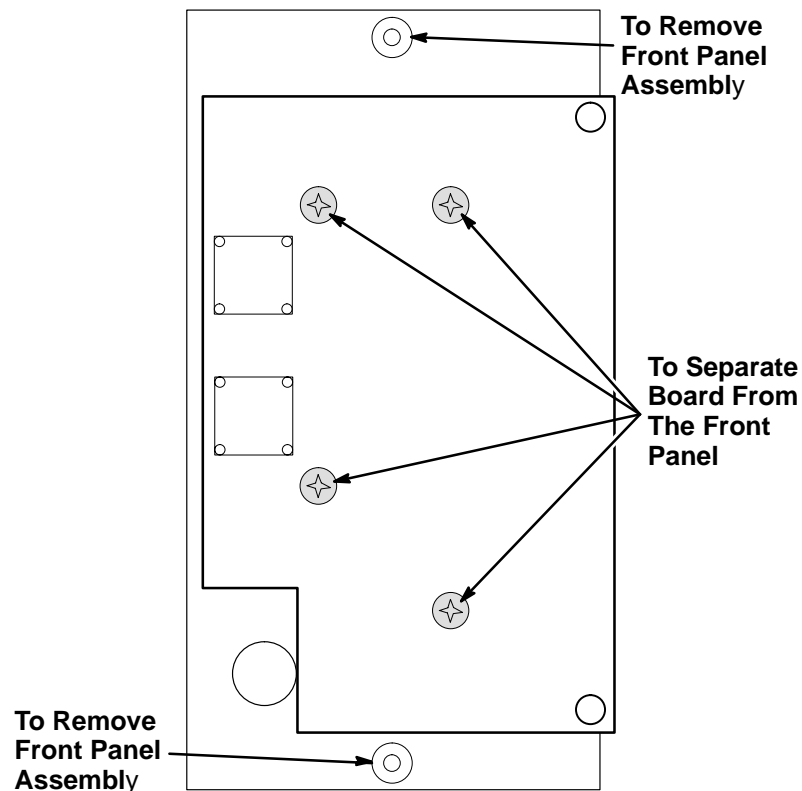

Figure 6-5: Screws that hold the Front Panel circuit board (A2) in place.

Removing the Main Board

1. Remove the plugs from the following connectors: J107 to the Front Panel board, J4 on the Power Supply board, and J225 on the Main board (the trace rotation leads to the CRT).
2. Unsolder the leads to the six bnc connectors and three ground from the rear panel, the two horizontal CRT leads (red and green), the PIX MON OUT, and the two vertical CRT leads (blue and brown).
3. Slip the CRT and trace rotation leads through the appropriate holes in the Main board.

4. Remove the eight screws that are holding the board in place. See Fig. 6-6 for their locations.

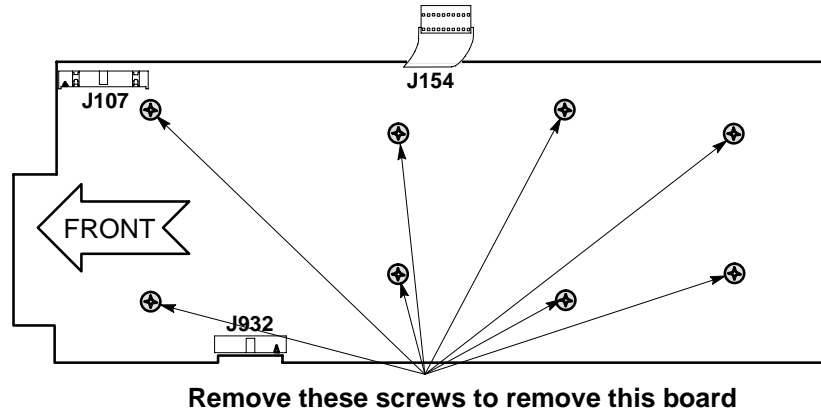

Figure 6-6: Screws holding the Main circuit board (A3) in place.

5. Remove the board by sliding it toward the rear panel until the toe of the board clears the front, then lift out.
6. To replace the Main board, lay the board flat and slide it back into place.
7. To complete the replacement of the board, reverse the rest of the steps.

Removing the Power Supply Board

1. Remove the plug from J4 on the Power Supply board, This is the connection to the Main board.
2. Remove the anode connection from the CRT and discharge it to ground.



WARNING. CRT Retained Charge Hazard:

The CRT may retain a dangerous charge. Ground the conductor of the anode to discharge the CRT. Do not allow the conductor to touch your body or any circuitry.

3. Unsolder the following connections: J1 pins 1 through 4, J3 pins 1 through 4, and the focus lead at J11. (If a 1700F10 Field Upgrade Kit is installed, unsolder leads to the rear-panel DC Connector.)
4. Disconnect the ac line filter from the rear panel by unscrewing its two mounting screws.
5. Use a #1 Pozidrive® tip to disconnect the power on/off switch from the front casting.

6. Remove the seven screws that are holding the Power Supply board down. See Fig. 6-7.
7. Remove the board by sliding it forward and lifting it up.
8. To replace the board, reverse this procedure.

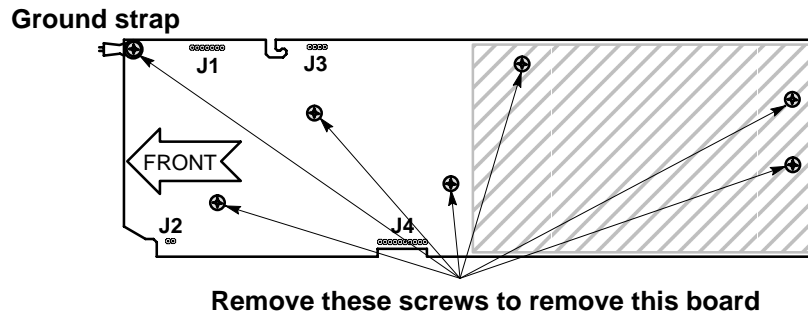

Figure 6-7: Screws holding the Power Supply circuit board (A1) in place.

Repackaging

Identification Tag

If the instrument is to be shipped to a Tektronix Service Center for service or repair, attach a tag to the instrument showing:

1. Owner (with complete address) and the name of the person at your firm that can be contacted.
2. Instrument serial number and a description of the service required.

Repackaging for Shipment

Repackage the instrument in the original manner to provide adequate protection (see Fig. 6-8). If the original packaging is not available or is unfit for use, repackage the instrument as follows:

1. Obtain a corrugated cardboard carton whose inside dimensions are at least six inches greater than the dimensions of the instrument to allow room for cushioning. The shipping carton should have a test strength of at least 275 pounds.
2. Surround the instrument with polyethylene sheeting to protect the finish.
3. Cushion the instrument on all sides by tightly packing dunnage or urethane foam between the carton and the instrument. Allow three inches on all sides for cushioning.
4. Seal the carton with shipping tape or an industrial stapler.

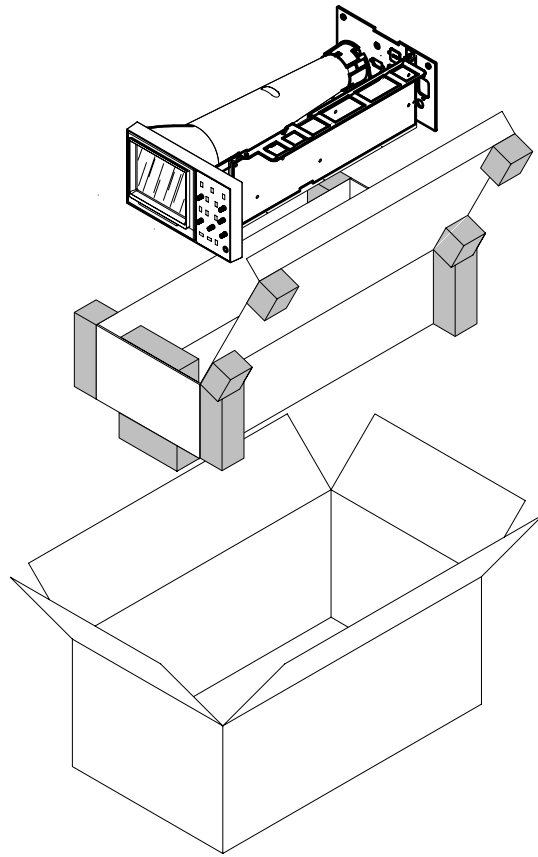

Figure 6-8: Repackaging a 1730-Series instrument.



Options

Section 7 Options

- CRT Options** The standard instrument is shipped with a P31 (green) phosphor CRT installed. If Option 74 is ordered, the instrument is shipped with a P4 (white) phosphor crt installed. The Option 74 CRT part number is given at the end of the Replaceable Electrical Parts list.
- Power Cord Options** Any of the following power cord options can be ordered for the 1730-Series. If no power cord option is ordered, instruments are shipped with a North American 125 V power cord and one replacement fuse.
- Option A1 Universal Europe 220V/16A Locking Power Plug (power cord and one replacement fuse)
- Option A2 United Kingdom 240V/15A Power Plug (power cord and one replacement fuse)
- Option A3 Australian 240V/10A Power Plug (power cord and one replacement fuse)
- Option A4 North American 250V/18A Power Plug (power cord and one replacement fuse)
- Option A5 Swiss 240V/6A Power Plug (power cord and one replacement fuse)
- Unless otherwise specified, power cords for use in North America are UL listed and CSA certified. Cords for use in areas other than North America are approved by at least one test house acceptable in the country to which the product is shipped. Power cord part numbers are shown on the pull-out in Section 10.

Cabinets

All of the Safety and EMI tests used to qualify the 1730-Series were performed in a cabinet. There are two optional cabinets and a dual rack adapter available for the installation of these instruments. Only a brief description is provided here, for more information contact a Tektronix field office or distributor.

- Plain Cabinet (1700F00)** This is a plain, silver-grey cabinet that is designed for permanent mounting. The pattern of ventilating holes in top, bottom, and sides provides adequate air circulation for any heat generated within the instrument. When being permanently mounted, care must be taken to allow the free circulation of air to and

from these ventilating holes. A drawing of this cabinet, that can be used in mounting the cabinet, is located in Section 3 (Installation) of this manual.

Carrying Case (1700F02)

This is a silver-grey, metal cabinet, with feet and carrying handle designed for portable applications. A TEKTRONIX BP1 can easily be mounted to this cabinet to provide a 12 Vdc power source for portable operation.

Side-by-Side Rack Adapter (1700F05)

This is a 19-inch, rack mounting adapter that accepts two 1700-Series instruments in a side-by-side configuration. Instrument cabinets are 1700F00 that are connected together for this installation. If only one 1700-Series instrument is to be installed in the Side-by-Side Rack Adapter, a blank panel (1700F06) can be installed for air flow protection, and appearance.

Blank Panel (1700F06)

When only one side of a 1700F05 dual rack adapter is used, this blank panel can be installed in the other half to improve appearance and protect air flow.

Utility Drawer (1700F07)

When only one side of a 1700F05 dual rack adapter is used, an alternate to the 1700F06 blank panel is the 1700F07 utility drawer. This drawer provides over 1/3 cubic foot of storage space for accessories. The drawer kit includes a tray, which is permanently mounted to the 1700F05. The drawer opens and closes readily, unless latched for transport. The drawer can also be removed from the drawer tray by lifting up and out.

Ordering

Any of these items can be ordered with the 1730-Series instrument. In addition, these items are available, along with accessory items listed in this manual, from your nearest Tektronix field office or distributor. Be sure to include both the name and number of any Field Upgrade Kits ordered.



Replaceable Electrical Parts

Section 8

Replaceable Electrical Parts

This section contains a list of the components that are replaceable for the 1730-Series. Use this list to identify and order replacement parts. There is a separate Replaceable Electrical Parts list for each instrument.

Parts Ordering Information

Replacement parts are available from or through your local Tektronix, Inc., Field Office or representative.

Changes to Tektronix instruments are sometimes made to accommodate improved components as they become available and to give you the benefit of the latest circuit improvements. Therefore, when ordering parts, it is important to include the following information in your order.

- Part number
- Instrument type or model number
- Instrument serial number
- Instrument modification number, if applicable

If a part you have ordered has been replaced with a new or improved part, your local Tektronix, Inc., Field Office or representative will contact you concerning any change in part number.

Change information, if any, is located at the rear of this manual.

Using the Replaceable Electrical Parts List

The tabular information in the Replaceable Electrical Parts list is arranged for quick retrieval. Understanding the structure and features of the list will help you find all of the information you need for ordering replaceable parts.

Cross Index–Mfr. Code Number to Manufacturer

The Mfg. Code Number to Manufacturer Cross Index for the electrical parts list is located immediately after this page. The cross index provides codes, names, and addresses of manufacturers of components listed in the electrical parts list.

Abbreviations

Abbreviations conform to American National Standards Institute (ANSI) standard Y1.1.

List of Assemblies

A list of assemblies can be found at the beginning of the electrical parts list. The assemblies are listed in numerical order. When the complete component number of a part is known, this list will identify the assembly in which the part is located.

Column Descriptions

Component No. (Column 1) The component circuit number appears on the diagrams and circuit board illustrations, located in the diagrams section. Assembly numbers are also marked on each diagram and circuit board illustration, in the Diagram section and on the mechanical exploded views, in the mechanical parts list. The component number is obtained by adding the assembly number prefix to the circuit number.

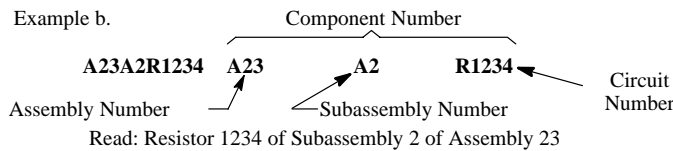
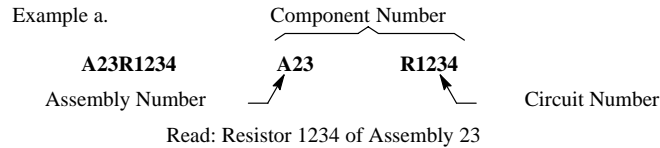

The electrical parts list is arranged by assemblies in numerical sequence (A1, with its subassemblies and parts, precedes A2, with its subassemblies and parts).

Mechanical subparts to the circuit boards are listed in the electrical parts list. These mechanical subparts are listed with their associated electrical part (for example, fuse holder follows fuse).

Chassis-mounted parts and cable assemblies have no assembly number prefix and are located at the end of the electrical parts list.

Tektronix Part No. (Column 2) Indicates part number to be used when ordering replacement part from Tektronix.

Serial/Assembly No. (Column 3 and 4) Column three (3) indicates the serial or assembly number at which the part was first used. Column four (4) indicates the serial or assembly number at which the part was removed. No serial or assembly number entered indicates part is good for all serial numbers.

Name and Description (Column 5) An item name is separated from the description by a colon (:). Because of space limitations, an item name may sometimes appear as incomplete. Use the U.S. Federal Catalog handbook H6-1 for further item name identification.

The mechanical subparts are shown as *ATTACHED PARTS* / *END ATTACHED PARTS* or *MOUNTING PARTS* / *END MOUNTING PARTS* in column five (5).

Mfr. Code (Column 6) Indicates the code number of the actual manufacturer of the part. (Code to name and address cross reference can be found immediately after this page.)

Mfr. Part No. (Column 7) Indicates actual manufacturer's part number.

Cross Index – Mfr. Code Number To Manufacturer

Mfr. Code.	Manufacturer	Address	City, State, Zip Code
00779	AMP INC	2800 FULLING MILL PO BOX 3608	HARRISBURG PA 17105
00853	SANGAMO WESTON INC COMPONENTS DIV	SANGAMO RD PO BOX 128	PICKENS SC 29671-9716
01121	ALLEN-BRADLEY CO INDUSTRIAL CONTROL PRODUCTS	1201 S 2ND ST	MILWAUKEE WI 53204-2410
01295	TEXAS INSTRUMENTS INC SEMICONDUCTOR GROUP	13500 N CENTRAL EXPY PO BOX 655012	DALLAS TX 75265
02735	RCA CORP SOLID STATE DIVISION		
04222	AVX CERAMICS DIV OF AVX CORP	19TH AVE SOUTH P O BOX 867	MYRTLE BEACH SC 29577
04713	MOTOROLA INC SEMICONDUCTOR PRODUCTS SECTOR	5005 E MCDOWELL RD	PHOENIX AZ 85008-4229
05397	UNION CARBIDE CORP MATERIALS SYSTEMS DIV	11901 MADISON AVE	CLEVELAND OH 44101
05820	EG AND G WAKEFIELD ENGINEERING	60 AUDUBON RD	WAKEFIELD MA 01880-1203
05828	GENERAL INSTRUMENT CORP GOVERNMENT SYSTEMS DIV	600 W JOHN ST	HICKSVILLE NY 11802
07263	FAIRCHILD SEMICONDUCTOR CORP		
07716	TRW INC TRW IRC FIXED RESISTORS/BURLINGTON	2850 MT PLEASANT AVE	BURLINGTON IA 52601
09023	CORNELL-DUBILIER ELECTRONICS DIV FEDERAL PACIFIC ELECTRIC CO	2652 DALRYMPLE ST	SANFORD NC 27330
09922	BURNDY CORP	RICHARDS AVE	NORWALK CT 06852
09969	DALE ELECTRONICS INC	EAST HIGHWAY 50 P O BOX 180	YANKTON SD 57078
12327	FREEWAY CORP	9301 ALLEN DR	CLEVELAND OH 44125-4632
12697	CLAROSTAT MFG CO INC	LOWER WASHINGTON ST	DOVER NH 03820
12969	MICROSEMI CORPORATION WATERTOWN DIVISION	530 PLEASANT STREET	WATERTOWN MA 02172
14433	ITT SEMICONDUCTORS DIV		WEST PALM BEACH FL
14552	MICROSEMI CORP	2830 S FAIRVIEW ST	SANTA ANA CA 92704-5948
15454	KETEMA RODAN DIVISION	2900 BLUE STAR STREET	ANAHEIM CA 92806-2591
15912	THOMAS AND BETTS CORP ELECTRONICS GROUP	76 FAIRBANKS	IRVINE CA 92718
17856	SILICONIX INC	2201 LAURELWOOD RD	SANTA CLARA CA 95054-1516
18796	MURATA ELECTRONICS NORTH AMERICA INC STATE COLLEGE OPERATIONS	1900 W COLLEGE AVE	STATE COLLEGE PA 16801-2723
19701	PHILIPS COMPONENTS DISCRETE PRODUCTS DIV RESISTIVE PRODUCTS FACILITY AIRPORT ROAD	PO BOX 760	MINERAL WELLS TX 76067-0760

1730-Series Replaceable Electrical Parts

Mfr. Code.	Manufacturer	Address	City, State, Zip Code
22526	BERG ELECTRONICS INC (DUPONT)	857 OLD TRAIL RD	ETTERS PA 17319
24165	SPRAGUE ELECTRIC CO	267 LOWELL ROAD	HUDSON NH 03051
24226	GOWANDA ELECTRONICS CORP	NO 1 INDUSTRIAL PL	GOWANDA NY 14070-1409
26364	COMPONENTS CORP	6 KINSEY PLACE	DENVILLE NJ 07834-2611
27014	NATIONAL SEMICONDUCTOR CORP	2900 SEMICONDUCTOR DR	SANTA CLARA CA 95051-0606
2M627	ROHM CORPORATION	PO BOX 19515	IRVINE CA 92713
34361	OMRON ELECTRONICS INC.		SUNNYVALE CA
37942	NORTH AMERICAN CAPACITOR CO MALLORY DIVISION	INDIANAPOLIS ROAD, HWY 240 PO BOX 240	GREEN CASTLE IN 46135 1
51406	MURATA ELECTRONICS NORTH AMERICA INC HEADQUARTERS AND GEORGIA OPERATIONS	2200 LAKE PARK DR	SMYRNA GA 30080
52769	SPRAGUE-GOODMAN ELECTRONICS INC	134 FULTON AVE	GARDEN CITY PARK NY 11040-5352
54583	TDK ELECTRONICS CORP	12 HARBOR PARK DR	PORT WASHINGTON NY 11550
55680	NICHICON /AMERICA/ CORP	927 E STATE PKY	SCHAUMBURG IL 60195-4526
56289	SPRAGUE ELECTRIC CO WORLD HEADQUARTERS		
56845	DALE ELECTRONICS INC	2300 RIVERSIDE BLVD PO BOX 74	NORFOLK NE 68701-2242
57668	ROHM CORP	8 WHATNEY PO BOX 19515	IRVINE CA 92713
58050	TEKA PRODUCTS INC	45 SALEM ST	PROVIDENCE RI 02907
59660	TUSONIX INC	7741 N BUSINESS PARK DR PO BOX 37144	TUCSON AZ 85740-7144
60395	XICOR INC	851 BUCKEYE CT	MILPITAS CA 95035-7408
73743	FISCHER SPECIAL MFG CO	111 INDUSTRIAL RD	COLD SPRING KY 41076-9749
74276	GENERAL INSTRUMENT CORP		
75915	LITTELFUSE INC SUB TRACOR INC	800 E NORTHWEST HWY	DES PLAINES IL 60016-3049
76493	BELL INDUSTRIES INC JW MILLER DIV	19070 REYES AVE PO BOX 5825	COMPTON CA 90224-5825
80009	TEKTRONIX INC	14150 SW KARL BRAUN DR PO BOX 500	BEAVERTON OR 97077-0001
84411	AMERICAN SHIZUKI CORP OGALLALA OPERATIONS	301 WEST O ST	OGALLALA NE 69153-1844
86928	SEASTROM MFG CO INC	701 SONORA AVE	GLENDALE CA 91201-2431
91637	DALE ELECTRONICS INC	2064 12TH AVE PO BOX 609	COLUMBUS NE 68601-3632
93907	TEXTRON INC CAMCAR DIV	600 18TH AVE	ROCKFORD IL 61108-5181
S3629	SCHURTER AG H C/O PANEL COMPONENTS CORP	2015 SECOND STREET	BERKELEY CA 94170
S4307	SCHAFFNER ELECTRONIK AG		LUTERBACH SWITZERLAND
TK1450	TOKYO COSMOS ELECTRIC CO LTD	2-268 SOBUDAI ZAWA	KANAGAWA 228 JAPAN
TK1462	YAMAICHI ELECTRONICS CO LTD 2ND FLOOR NEW KYOEI	3-CHROME SHIBAURA MINATO-KU	TOKYO JAPAN

1730-Series Replaceable Electrical Parts

Mfr. Code.	Manufacturer	Address	City, State, Zip Code
	BLDG 17-11		
TK1573	WILHELM WESTERMAN	PO BOX 2345 AUGUSTA-ANLAGE 56	6800 MANNHEIM 1 WEST GERMANY
TK1913	WIMA THE INTER-TECHNICAL GROUP IND	2269 SAW MILL RIVER ROAD PO BOX 127	ELMSFORD NY 10523

1730-Series Replaceable Electrical Parts

Replaceable Electrical Parts

Component Number	Tektronix Part Number	Serial / Assembly Number Effective	Discontinued	Name & Description	Mfr. Code	Mfr. Part Number
A1	671-2890-11		B079210	CIRCUIT BD ASSY:POWER SUPPLY (1730 ONLY)	80009	671289010
A1	671-2890-11		B079467	CIRCUIT BD ASSY:POWER SUPPLY (1731 ONLY)	80009	671289010
A1	671-2890-11		B079479	CIRCUIT BD ASSY:POWER SUPPLY (1731 PM ONLY)	80009	671289010
A1	671-2890-11		B072609	CIRCUIT BD ASSY:POWER SUPPLY (1735 ONLY)	80009	671289010
A1	671-2890-11		B072606	CIRCUIT BD ASSY:POWER SUPPLY (1735 BB ONLY)	80009	671289010
A1	671-2890-12	B079211		CIRCUIT BD ASSY:POWER SUPPLY (1730 ONLY)	80009	671289010
A1	671-2890-12	B079468		CIRCUIT BD ASSY:POWER SUPPLY (1731 ONLY)	80009	671289010
A1	671-2890-12	B079480		CIRCUIT BD ASSY:POWER SUPPLY (1731 PM ONLY)	80009	671289010
A1	671-2890-12	B072610		CIRCUIT BD ASSY:POWER SUPPLY (1735 ONLY)	80009	671289010
A1	671-2890-12	B072607		CIRCUIT BD ASSY:POWER SUPPLY (1735 BB ONLY)	80009	671289010
A2	670-9388-01			CIRCUIT BD ASSY:FRONT PNL	80009	670-9388-00
A3	672-1229-14			CIRCUIT BD ASSY:MAIN (1730, 1731)	80009	672-1229-14
A3	672-1266-15			CIRCUIT BD ASSY:MAIN (1735 ONLY)	80009	672-1266-15
A3	672-0225-13			CIRCUIT BD ASSY:MAIN (1731 PM ONLY)	80009	672-0225-13
A3A1	671-1796-01			CIRCUIT BD ASSY:GRATICULE LIGHT	80009	671-1796-00
A10	671-3637-00			CIRCUIT BD ASSY:CRT SOCKET BD	80009	671363700
A11	671-3761-00			CIRCUIT BD ASSY:SERIAL FILTER	80009	671376100
A1	671-2890-11		B079210	CIRCUIT BD ASSY:POWER SUPPLY (1730 ONLY)	80009	671289010
A1	671-2890-11		B079467	CIRCUIT BD ASSY:POWER SUPPLY (1731 ONLY)	80009	671289010
A1	671-2890-11		B079479	CIRCUIT BD ASSY:POWER SUPPLY (1731 PM ONLY)	80009	671289010
A1	671-2890-11		B072609	CIRCUIT BD ASSY:POWER SUPPLY (1735 ONLY)	80009	671289010
A1	671-2890-11		B072606	CIRCUIT BD ASSY:POWER SUPPLY (1735 BB ONLY)	80009	671289010
A1	671-2890-12	B079211		CIRCUIT BD ASSY:POWER SUPPLY (1730 ONLY)	80009	671289010
A1	671-2890-12	B079468		CIRCUIT BD ASSY:POWER SUPPLY (1731 ONLY)	80009	671289010
A1	671-2890-12	B079480		CIRCUIT BD ASSY:POWER SUPPLY (1731 PM ONLY)	80009	671289010
A1	671-2890-12	B072610		CIRCUIT BD ASSY:POWER SUPPLY (1735 ONLY)	80009	671289010
A1	671-2890-12	B072607		CIRCUIT BD ASSY:POWER SUPPLY (1735 BB ONLY)	80009	671289010
A1C1	281-0775-01			CAP,FXD,CERAMIC:MCL:0.1UF,20%,50V,Z5U,0.170	04222	SA105E104MAA
A1C2	283-0021-00			CAP,FXD,CER DI:0.001UF,20%,5000V	TK2058	TCK45YS3H102M-A
A1C3	283-0261-00			CAP,FXD,CER DI:0.01UF,20%,4000V	18796	DHR28Z5U103M4KV
A1C4	283-0261-00			CAP,FXD,CER DI:0.01UF,20%,4000V	18796	DHR28Z5U103M4KV
A1C5	285-1341-01			CAP,FXD,PLASTIC:MTLZD FILM;0.1UF,20%,100V,POLYEST	TK1913	MKS 2 0.1UF 20%
A1C6	281-0771-00			CAP,FXD,CER DI:2200PF,20%,200V	04222	SA102C222MAA
A1C7	285-1470-00			CAP,FXD,PLASTIC:MTLZD FILM;330PF,1600VDC/500VAC, POLYPROPYLENE,11 X18	TK1913	FKP1 330/1600/5
A1C8	283-0261-00			CAP,FXD,CER DI:0.01UF,20%,4000V	18796	DHR28Z5U103M4KV
A1C9	283-0261-00			CAP,FXD,CER DI:0.01UF,20%,4000V	18796	DHR28Z5U103M4KV
A1C10	281-0563-00			CAP,FXD,CERAMIC:MCL:0.47UF,20%,50V,0.150 X0.290	04222	SA305E474MAA
A1C11	283-0021-00			CAP,FXD,CER DI:0.001UF,20%,5000V	TK2058	TCK45YS3H102M-A
A1C12	281-0707-00			CAP,FXD,CER DI:15000PF,10%,200V	04222	MA302C153KAA
A1C13	281-0707-00			CAP,FXD,CER DI:15000PF,10%,200V	04222	MA302C153KAA
A1C14	281-0707-00			CAP,FXD,CER DI:15000PF,10%,200V	04222	MA302C153KAA
A1C15	285-1341-01			CAP,FXD,PLASTIC:MTLZD FILM;0.1UF,20%,100V,POLYEST	TK1913	MKS 2 0.1UF 20%
A1C16	290-1311-00			CAP,FXD,ALUM:10UF,20%,50V,ESR=1.4 OHM (100KHZ,20C),5X11MM,105C,5000HRS	55680	UPL1H100MDH1TD
A1C17	285-1341-01			CAP,FXD,PLASTIC:MTLZD FILM;0.1UF,20%,100V,POLYEST	TK1913	MKS 2 0.1UF 20%
A1C18	281-0775-01			CAP,FXD,CERAMIC:MCL:0.1UF,20%,50V,Z5U,0.170	04222	SA105E104MAA
A1C19	290-1310-00			CAP,FXD,ALUM:10UF,20%,160V,ESR=24.9 OHM (120HZ,20C),LS=0.200INCH,13X20MM,105C,5000HRS	0H1N5	CEJSM2C100M
A1C20	281-0707-00			CAP,FXD,CER DI:15000PF,10%,200V	04222	MA302C153KAA

1730-Series Replaceable Electrical Parts

Component Number	Tektronix Part Number	Serial / Assembly Number		Name & Description	Mfr. Code	Mfr. Part Number
		Effective	Discontinued			
A1C21	281-0707-00			CAP,FXD,CER DI:15000PF,10%,200V	04222	MA302C153KAA
A1C22	281-0563-00			CAP,FXD,CERAMIC:MLC:0.47UF,20%,50V,0.150 X0.290	04222	SA305E474MAA
A1C23	285-1328-00			CAP,FXD,PLASTIC:MTLZD FILM:0.01UF,5%,2000V,POLY-PROPYLENE,1.25X.95	TK1913	FKP1 .01/2000/5
A1C24	290-1310-00			CAP,FXD,ALUM:10UF,20%,160V,ESR=24.9 OHM (120HZ,20C),LS=0.200 INCH,13X20MM,105C,5000HRS	0H1N5	CEJSM2C100M
A1C25	281-0775-01			CAP,FXD,CERAMIC:MCL:0.1UF,20%,50V,Z5U,0.170	04222	SA105E104MAA
A1C27	281-0775-01			CAP,FXD,CERAMIC:MCL:0.1UF,20%,50V,Z5U,0.170	04222	SA105E104MAA
A1C28	281-0775-01			CAP,FXD,CERAMIC:MCL:0.1UF,20%,50V,Z5U,0.170	04222	SA105E104MAA
A1C29	290-1267-00			CAP,FXD,ALUM:560UF,20%,50V,ESR=0.40 OHM (100KHZ,20C)	0H1N5	CEEFM1H561M7
A1C30	290-1267-00			CAP,FXD,ALUM:560UF,20%,50V,ESR=0.40 OHM (100KHZ,20C)	0H1N5	CEEFM1H561M7
A1C31	290-1267-00			CAP,FXD,ALUM:560UF,20%,50V,ESR=0.40 OHM (100KHZ,20C)	0H1N5	CEEFM1H561M7
A1C32	290-1267-00			CAP,FXD,ALUM:560UF,20%,50V,ESR=0.40 OHM (100KHZ,20C)	0H1N5	CEEFM1H561M7
A1C33	290-1310-00			CAP,FXD,ALUM:10UF,20%,160V,ESR=24.9 OHM (120HZ,20C),LS=0.200 INCH,13X20MM,105C,5000HRS	0H1N5	CEJSM2C100M
A1C34	290-1310-00			CAP,FXD,ALUM:10UF,20%,160V,ESR=24.9 OHM (120HZ,20C),LS=0.200 INCH,13X20MM,105C,5000HRS	0H1N5	CEJSM2C100M
A1C35	290-1267-00			CAP,FXD,ALUM:560UF,20%,50V,ESR=0.40 OHM (100KHZ,20C)	0H1N5	CEEFM1H561M7
A1C36	290-1267-00			CAP,FXD,ALUM:560UF,20%,50V,ESR=0.40 OHM (100KHZ,20C)	0H1N5	CEEFM1H561M7
A1C37	290-1267-00			CAP,FXD,ALUM:560UF,20%,50V,ESR=0.40 OHM (100KHZ,20C)	0H1N5	CEEFM1H561M7
A1C38	290-1267-00			CAP,FXD,ALUM:560UF,20%,50V,ESR=0.40 OHM (100KHZ,20C)	0H1N5	CEEFM1H561M7
A1C39	281-0775-01			CAP,FXD,CERAMIC:MCL:0.1UF,20%,50V,Z5U,0.170	04222	SA105E104MAA
A1C40	281-0772-00			CAP,FXD,CERAMIC:MLC;4700PF,10%,100V,0.100 X	04222	SA101C472KAA
A1C41	281-0563-00			CAP,FXD,CERAMIC:MLC:0.47UF,20%,50V,0.150 X0.290	04222	SA305E474MAA
A1C42	290-1267-00			CAP,FXD,ALUM:560UF,20%,50V,ESR=0.40 OHM (100KHZ,20C)	0H1N5	CEEFM1H561M7
A1C43	281-0563-00			CAP,FXD,CERAMIC:MLC:0.47UF,20%,50V,0.150 X 0.290	04222	SA305E474MAA
A1C44	285-1331-00			CAP,FXD,MTLZD:0.47UF,5%,400V,	TK1913	MKS4 .47/400/5
A1C45	281-0563-00			CAP,FXD,CERAMIC:MLC;0.47UF,20%,50V,0.150 X 0.290	04222	SA305E474MAA
A1C46	283-0005-03			CAP,FXD,CER DI:0.01 UF,+80-20%,250V	04222	SR30VE103ZAATR2
A1C47	281-0563-00		671-2890-11	CAP,FXD,CERAMIC:MLC:0.47UF,20%,50V,0.150 X 0.290	04222	SA305E474MAA
A1C47	283-0059-00	671-2890-12		CAP,FXD,CERAMIC:MLC;1.0UF,20%,50V,0.150 X 0.290	04222	SA305E474MAA
A1C48	281-0809-00			CAP,FXD,CERAMIC:MLC;200 PF,5%,100V,0.100 X 0.170	04222	SA101A201JAA
A1C49	281-0775-01			CAP,FXD,CERAMIC:MCL:0.1UF,20%,50V,Z5U,0.170	04222	SA105E104MAA
A1C50	281-0563-00			CAP,FXD,CERAMIC:MLC:0.47UF,20%,50V,0.150 X 0.290	04222	SA305E474MAA
A1C51	281-0773-00			CAP,FXD,CERAMIC:MLC:0.01UF,10%,100V	TK1743	CGB103KEX
A1C52	281-0773-00			CAP,FXD,CERAMIC:MLC;0.01UF,10%,100V	TK1743	CGB103KEX
A1C53	285-1437-00			CAP,FXD,PLASTIC:100PF,5%,1600VDC/500VAC	TK1913	FKP1/100/1600/5
A1C54	290-1275-00			CAP,FXD,ALUM:330UF,20%,400V,35X35MM,105C	55680	LQ2G331MHSC
A1C56	285-1246-00			CAP,FXD,PPR DI:0.022UF,20%,250VAC	TK0515	PME 289 MB 5220
A1C57	285-1222-00			CAP,FXD,PLASTIC:0.068UF,20%,250V	TK0515	PME 271 M 568
A1C58	281-0809-00			CAP,FXD,CERAMIC:MLC;200 PF,5%,100V,0.100 X 0.170	04222	SA101A201JAA
A1C59	281-0775-01			CAP,FXD,CERAMIC:MCL:0.1UF,20%,50V,Z5U,0.170	04222	SA105E104MAA
A1C60	281-0775-01			CAP,FXD,CERAMIC:MCL:0.1UF,20%,50V,Z5U,0.170	04222	SA105E104MAA
A1C61	281-0768-00			CAP,FXD,CER DI:470PF,20%,100V	04222	SA101A471KAA
A1C65	285-1301-01			CAP,FXD,MTLZD:0.47UF,10%,50VTAPE & AMMO PACK	TK1913	MKS 2 .47/50 OR
A1C66	290-1311-00			CAP,FXD,ALUM:10UF,20%,50V,ESR=1.4 OHM (100KHZ,20C),5X11MM,105C,5000HRS	55680	UPL1H100MDH1TD
A1CR1	152-0061-00			DIODE,SIG:200V,0.1A,700NS,4.OPF	12969	PV122
A1CR2	152-0061-00			DIODE,SIG:200V,0.1A,700NS,4.OPF	12969	PV122
A1CR3	152-0061-00			DIODE,SIG:200V,0.1A,700NS,4.OPF	12969	PV122
A1CR4	152-0409-00			DIODE,RECT:FAST RCVRY;12KV,10MA,250NS	83701	CRVT150
A1CR5	152-0061-00			DIODE,SIG:200V,0.1A,700NS,4.OPF	12969	PV122

1730-Series Replaceable Electrical Parts

Component Number	Tektronix Part Number	Serial / Assembly Number		Name & Description	Mfr. Code	Mfr. Part Number
		Effective	Discontinued			
A1CR6	152-0061-00			DIODE,SIG:200V,0.1A,700NS,4.0PF	12969	PV122
A1CR7	152-0400-00			DIODE,RECT:FAST RCVRY:400V,1A,200NS	0LUA3	1N4936
A1CR8	152-0400-00			DIODE,RECT:FAST RCVRY:400V,1A,200NS	0LUA3	1N4936
A1CR9	152-0400-00			DIODE,RECT:FAST RCVRY:400V,1A,200NS	0LUA3	1N4936
A1CR10	152-0400-00			DIODE,RECT:FAST RCVRY:400V,1A,200NS	0LUA3	1N4936
A1CR11	152-0814-00		671-2890-11	DIODE,RECT:ULTRA FAST:150V,3A,1.1VF,30NS	0LUA3	BYV28-150
A1CR11	152-0808-00	671-2890-12		DIODE,RECT:ULTRA FAST:150V,3A,1.1VF,30NS	0LUA3	BYV28-150
A1CR12	152-0400-00			DIODE,RECT:FAST RCVRY:400V,1A,200NS	0LUA3	1N4936
A1CR13	152-1191-00			DIODE,RECT:SCHTKY;100V,10A,150A IFSM,800MVF AT 10A	04713	MBR10100
A1CR14	152-0400-00			DIODE,RECT:FAST RCVRY:400V,1A,200NS	0LUA3	1N4936
A1CR15	152-0400-00			DIODE,RECT:FAST RCVRY:400V,1A,200NS	0LUA3	1N4936
A1CR16	152-0141-02			DIODE,SIG:ULTRA FAST:40V,150MA,4NS,2PF	27014	FDH9427
A1CR17	152-0400-00			DIODE,RECT:FAST RCVRY:400V,1A,200NS	0LUA3	1N4936
A1CR19	152-0141-02			DIODE,SIG:ULTRA FAST:40V,150MA,4NS,2PF	27014	FDH9427
A1CR20	152-0897-00			DIODE,RECT:FAST RCVRY:1000V,1.5A,300NS	0LUA3	BYV96E
A1CR21	152-1165-00			DIODE,RECT:ULTRA FAST:600V,4A,50NS	04713	MUR460RL
A1CR22	152-1165-00			DIODE,RECT:ULTRA FAST:600V,4A,50NS	04713	MUR460RL
A1CR23	152-1165-00			DIODE,RECT:ULTRA FAST:600V,4A,50NS	04713	MUR460RL
A1CR24	152-1165-00			DIODE,RECT:ULTRA FAST:600V,4A,50NS	04713	MUR460RL
A1CR25	152-0141-02			DIODE,SIG:ULTRA FAST:40V,150MA,4NS,2PF	27014	FDH9427
A1CR26	152-0141-02			DIODE,SIG:ULTRA FAST:40V,150MA,4NS,2PF	27014	FDH9427
A1CR27	152-0400-00			DIODE,RECT:FAST RCVRY:400V,1A,200NS	0LUA3	1N4936
A1CR29	152-0400-00			DIODE,RECT:FAST RCVRY:400V,1A,200NS	0LUA3	1N4936
A1CR30	152-0141-02			DIODE,SIG:ULTRA FAST:40V,150MA,4NS,2PF	27014	FDH9427
A1CR31	152-0400-00			DIODE,RECT:FAST RCVRY:400V,1A,200NS	0LUA3	1N4936
A1DS1	150-0050-00			LAMP,GLOW:135V MAX,1.9MA,C2A-T,WIRE LEAD	OJ9R2	NE-2Q-11R-T
A1DS2	150-0050-00			LAMP,GLOW:135V MAX,1.9MA,C2A-T,WIRE LEAD	OJ9R2	NE-2Q-11R-T
A1DS3	150-0050-00			LAMP,GLOW:135V MAX,1.9MA,C2A-T,WIRE LEAD	OJ9R2	NE-2Q-11R-T
A1DS4	150-0050-00			LAMP,GLOW:135V MAX,1.9MA,C2A-T,WIRE LEAD	OJ9R2	NE-2Q-11R-T
A1F1	159-0021-00			FUSE,CARTRIDGE:3AG,2A,250V,FAST BLOW	71400	AGC-2
				MOUNTING PARTS		
	200-2264-00			CAP,FUSEHOLDER:3AG FUSES	61935	FEK 031 1666
	204-0906-00			BODY,FUSEHOLDER:3AG & 5 X 20MM FUSES	61935	TYPE FAU 031.35
				END MOUNTING PARTS		
A1J1	131-5338-00			CONN,HDR:PCB/WIREWRAP;MALE,STR,1 X 7,0.15CTR,0.230 MLG X 0.285 TAIL,30 GOLD,SIDE BY SIDE STACK	22526	65561-107
A1J2	131-4794-00			CONN,HDR:PCB:MALE,STR,1 X 2,0.1 CTR,0.235 MLG X 0.112 TAIL,30GOLD,0.035 DIA PCB	53387	2402-6112 UB
A1J3	131-5337-00			CONN,HDR:PCB/WIREWRAP;MALE,STR,1 X 4,0.150	22526	65561-104
A1J4	131-3392-00			CONN,HDR:PCB:MALE,STR,1 X 10,0.1 CTR,0.230	00779	1-102844-1
A1J6	119-1946-00			FILTER,RFI:1A,250V,400HZ W/PC TERMINAL	0GV52	FX326-1/02-K-D-
A1L1	108-1412-00			INDUCTOR,FXD:POWER:4.7UH,20%,I<3.7A,RDC<0.017 OHM,Q>10,SRF>30MHZ,BOBBIN	TK2058	TSL0807-4R7M3R0
A1L2	108-1412-00			INDUCTOR,FXD:POWER:4.7UH,20%,I<3.7A,RDC<0.017 OHM,Q>10,SRF>30MHZ,BOBBIN	TK2058	TSL0807-4R7M3R0
A1L3	108-1412-00			INDUCTOR,FXD:POWER:4.7UH,20%,I<3.7A,RDC<0.017 OHM,Q>10,SRF>30MHZ,BOBBIN	TK2058	TSL0807-4R7M3R0
A1L4	108-0205-00			INDUCTOR,FXD:POWER:1MH,5%,IDC<400 MA,RDC<2.12 OHM,Q>47@0.25MHZ	76493	8209
A1Q1	151-0749-00			TRANSISTOR,SIG:BIPOLAR,PNP:400V,500MA,50MHZ,AMPL	04713	MPSA94
A1Q2	151-0190-00			TRANSISTOR,SIG:BIPOLAR,NPN:40V,200MA,300MHZ,AMPL	OJR04	2N3904
A1Q3	151-0350-03			TRANSISTOR,SIG:BIPOLAR,PNP:150V,600MA,100MHZ	04713	2N5401RLRP
A1Q4	151-0347-02			TRANSISTOR,SIG:BIPOLAR,NPN:160V,600MA,100MHZ	04713	2N5551RLRP
A1Q5	151-0350-03			TRANSISTOR,SIG:BIPOLAR,PNP:150V,600MA,100MHZ	04713	2N5401RLRP
A1Q6	151-0476-00			TRANSISTOR,PWR:BIPOLAR,NPN:100V,3.0A,3.0MHZ,AMPL	04713	TIP31C
				ATTACHED PARTS		
	214-3848-00			HEAT SINK,SEMIC:XSTR,TO-220;ALUMINUM,CLIP-ON	13103	6043PB
				END ATTACHED PARTS		
A1Q7	151-0190-00			TRANSISTOR,SIG:BIPOLAR,NPN:40V,200MA,300MHZ,AMPL	OJR04	2N3904

1730-Series Replaceable Electrical Parts

Component Number	Tektronix Part Number	Serial / Assembly Number		Name & Description	Mfr. Code	Mfr. Part Number
		Effective	Discontinued			
A1Q8	151-0190-00			TRANSISTOR,SIG:BIPOLAR,NPN;40V,200MA,300MHZ,AMPL	0JR04	2N3904
A1Q9	151-1286-00			TRANSISTOR,PWR:MOS,N-CH;800V,4.0A,3.0 OHM	0LUA3	BUK456-800A
				ATTACHED PARTS		
	210-0406-00			NUT,PLAIN,HEX:4-40 X 0.188,BRS CD PL	73743	12161-50
	211-0008-00			SCREW,MACHINE:4-40 X 0.25,PNH,STL	TK0435	ORDER BY DESC
	214-3841-00			HEAT SINK,SEMIC:TRANSISTOR,TO-220;VERTICAL-MOUNT,(2)SOLDERABLE TABS,ALUM,BLACK ANODIZE	13103	6021PB
				END ATTACHED PARTS		
A1Q10	151-0350-03			XSTR,SIG:BIPOLAR,PNP;150V,600MA,100MHZ,AMPL	04713	2N5401RLRP
A1Q11	151-0528-00			THYRISTOR,PWR:BIPOLAR,SCR:50V,16A RMS,PHASE	0LUA3	BT152-400R
A1R1	303-0155-00			RES,FXD,CMPSN:1.5M OHM,5%,1W	50139	GB1555
A1R2	301-0225-02			RES,FXD,CMPSN:2.2M OHM,5%,0.5W	50139	EB2255
A1R3	303-0155-00			RES,FXD,CMPSN:1.5M OHM,5%,1W	50139	GB1555
A1R4	303-0155-00			RES,FXD,CMPSN:1.5M OHM,5%,1W	50139	GB1555
A1R5	303-0155-00			RES,FXD,CMPSN:1.5M OHM,5%,1W	50139	GB1555
A1R7	322-3385-00			RES,FXD:METAL FILM;100K OHM,1%,0.2W,TC=100 PPM	91637	CCF501G10002F
A1R8	322-3097-00			RES,FXD:METAL FILM;100 OHM,1%,0.2W,TC=100 PPM	91637	CCF501G100R0F
A1R11	311-1256-00			RES,VAR,TRMR:CERMET;2.5M OHM,10%,0.5W,0.375	32997	3386F-1-255
A1R12	315-0471-03			RES,FXD,CMPSN:470 OHM,5%,0.25W	50139	CB4715
A1R13	322-3097-00			RES,FXD:METAL FILM;100 OHM,1%,0.2W,TC=100 PPM	91637	CCF501G100R0F
A1R14	322-3001-00			RES,FXD:METAL FILM;10 OHM,1%,0.2W,TC=100 PPM	91637	CCF501G10R00F
A1R20	322-3248-00			RES,FXD,FILM:3.74K OHM,1%,0.2W,TC=T0TAPED &	91637	CCF50G37400F
A1R22	322-3329-00			RES,FXD,FILM:26.1K OHM,1%,0.2W,TC=T0MI	91637	CCF501G26101F
A1R24	322-3097-00			RES,FXD:METAL FILM;100 OHM,1%,0.2W,TC=100 PPM	91637	CCF501G100R0F
A1R25	322-3097-00			RES,FXD:METAL FILM;100 OHM,1%,0.2W,TC=100 PPM	91637	CCF501G100R0F
A1R26	322-3452-00			RES,FXD,FILM:499K OHM,1%,0.2W,TC=T0MI,SMALL	91637	CCF50-2-G4993FT
A1R27	322-3300-02			RES,FXD,FILM:13K OHM,0.5%,0.2W,TC=T2	91637	CCF501D13001D
A1R28	322-3344-00			RES,FXD,FILM:37.4K OHM,1%,0.2W,TC=T0MI	91637	CCF501G37401F
A1R29	315-0470-03			RES,FXD,CMPSN:47 OHM,5%,0.25W	50139	CB4705
A1R30	315-0103-03			RES,FXD,CMPSN:10K OHM,5%,0.25W	50139	CB1035
A1R31	322-3385-00			RES,FXD:METAL FILM;100K OHM,1%,0.2W,TC=100 PPM	91637	CCF501G10002F
A1R32	322-3452-00			RES,FXD,FILM:499K OHM,1%,0.2W,TC=T0MI,SMALL	91637	CCF50-2-G4993FT
A1R33	322-3300-02			RES,FXD,FILM:13K OHM,0.5%,0.2W,TC=T2	91637	CCF501D13001D
A1R34	322-3222-00			RES,FXD:METAL FILM;2K OHM,1%,0.2W,TC=100 PPM	91637	CCF501G20000F
A1R35	322-3162-00			RES,FXD:METAL FILM;475 OHM,1%,0.2W,TC=100 PPM	91637	CCF50G475R0F
A1R36	322-3222-00			RES,FXD:METAL FILM;2K OHM,1%,0.2W,TC=100 PPM	91637	CCF501G20000F
A1R37	322-3034-00			RES,FXD:METAL FILM;22.1 OHM,1%,0.2W,TC=100 PPM	91637	CCF50-2-G22R10F
A1R38	315-0226-01			RES,FXD,CMPSN:22 M OHM,5%,0.25W	50139	CB2265
A1R39	315-0471-03			RES,FXD,CMPSN:470 OHM,5%,0.25W	50139	CB4715
A1R40	315-0103-03			RES,FXD,CMPSN:10K OHM,5%,0.25W	50139	CB1035
A1R41	322-3121-00			RES,FXD:METAL FILM;178 OHM,1%,0.2W,TC=100 PPM	91637	CCF501G178R0F
A1R42	322-3402-00			RES,FXD:METAL FILM;150K OHM,1%,0.2W,TC=100 PPM	91637	CCF50G15002F
A1R43	315-0471-03			RES,FXD,CMPSN:470 OHM,5%,0.25W	50139	CB4715
A1R44	315-0471-03			RES,FXD,CMPSN:470 OHM,5%,0.25W	50139	CB4715
A1R45	311-2239-00			RES,VAR,TRMR:CERMET;100K OHM,20%,0.5W,0.197	TK2073	GF06UT2 104 M L
A1R46	322-3001-00			RES,FXD:METAL FILM;10 OHM,1%,0.2W,TC=100 PPM	91637	CCF501G10R00F
A1R47	322-3385-00			RES,FXD:METAL FILM;100K OHM,1%,0.2W,TC=100 PPM	91637	CCF501G10002F
A1R48	322-3239-00			RES,FXD,FILM:3.01K OHM,1%,0.2W,TC=T0MI	91637	CCF501G30100F
A1R49	311-2236-00			RES,VAR,TRMR:CERMET;20K OHM,20%,0.5W,0.197	TK2073	GF06UT2 104 M L
A1R50	322-3001-00			RES,FXD:METAL FILM;10 OHM,1%,0.2W,TC=100 PPM	91637	CCF501G10R00F
A1R51	322-3260-00			RES,FXD,FILM:4.99K OHM,1%,0.2W,TC=T0TAPED &	91637	CCF501G49900F
A1R52	322-3001-00			RES,FXD:METAL FILM;10 OHM,1%,0.2W,TC=100 PPM	91637	CCF501G10R00F
A1R53	322-3001-00			RES,FXD:METAL FILM;10 OHM,1%,0.2W,TC=100 PPM	91637	CCF501G10R00F
A1R54	322-3260-00			RES,FXD,FILM:4.99K OHM,1%,0.2W,TC=T0TAPED &	91637	CCF501G49900F
A1R55	322-3322-00			RES,FXD:METAL FILM;22.1K OHM,1%,0.2W,TC=100	91637	CCF501G22101F
A1R56	322-3001-00			RES,FXD:METAL FILM;10 OHM,1%,0.2W,TC=100 PPM	91637	CCF501G10R00F
A1R57	322-3034-00			RES,FXD:METAL FILM;22.1 OHM,1%,0.2W,TC=100 PPM	91637	CCF50-2-G22R10F
A1R58	311-2239-00			RES,VAR,TRMR:CERMET;100K OHM,20%,0.5W,0.197	TK2073	GF06UT2 104 M L

1730-Series Replaceable Electrical Parts

Component Number	Tektronix Part Number	Serial / Assembly Number		Name & Description	Mfr. Code	Mfr. Part Number
		Effective	Discontinued			
A1R59	322-3485-07			RES,FXD,FILM:5K OHM,0.1%,0.2W,TC=T9	91637	CCF501C50000B
A1R60	322-3268-00			RES,FXD,FILM:6.04K OHM,1%,0.2W,TC=TOMI	91637	CCF501G60400F
A1R61	322-3034-00			RES,FXD:METAL FILM:22.1 OHM,1%,0.2W,TC=100 PPM	91637	CCF50-2-G22R10F
A1R62	322-3097-00			RES,FXD:METAL FILM:100 OHM,1%,0.2W,TC=100 PPM	91637	CCF501G100R0F
A1R63	322-3222-00			RES,FXD:METAL FILM:2K OHM,1%,0.2W,TC=100 PPM	91637	CCF501G20000F
A1R64	322-3385-00			RES,FXD:METAL FILM:100K OHM,1%,0.2W,TC=100 PPM	91637	CCF501G10002F
A1R65	322-3385-00			RES,FXD:METAL FILM:100K OHM,1%,0.2W,TC=100 PPM	91637	CCF501G10002F
A1R66	322-3452-00			RES,FXD,FILM:499K OHM,1%,0.2W,TC=TOMI,SMALL	91637	CCF50-2-G4993FT
A1R67	322-3001-00			RES,FXD:METAL FILM:10 OHM,1%,0.2W,TC=100 PPM	91637	CCF501G10R00F
A1R68	322-3121-00			RES,FXD:METAL FILM:178 OHM,1%,0.2W,TC=100 PPM	91637	CCF501G178R0F
A1R69	322-3289-07			RES,FXD,FILM:10K OHM,0.1%,0.2W,TC=T9,T&R	91637	CCF501C10001B
A1R70	322-3289-07			RES,FXD,FILM:10K OHM,0.1%,0.2W,TC=T9,T&R	91637	CCF501C10001B
A1R71	322-3418-00			RES,FXD:METAL FILM:221K OHM,1%,0.2W,TC=100 PPM	91637	CCF501G22102F
A1R72	322-3001-00			RES,FXD:METAL FILM:10 OHM,1%,0.2W,TC=100 PPM	91637	CCF501G10R00F
A1R73	322-3001-00			RES,FXD:METAL FILM:10 OHM,1%,0.2W,TC=100 PPM	91637	CCF501G10R00F
A1R74	322-3260-00			RES,FXD,FILM:4.99K OHM,1%,0.2W,TC=T0TAPED &	91637	CCF501G49900F
A1R75	322-3260-00			RES,FXD,FILM:4.99K OHM,1%,0.2W,TC=T0TAPED &	91637	CCF501G49900F
A1R76	322-3248-00			RES,FXD,FILM:3.74K OHM,1%,0.2W,TC=T0TAPED &	91637	CCF50G37400F
A1R77	322-3097-00			RES,FXD:METAL FILM:100 OHM,1%,0.2W,TC=100 PPM	91637	CCF501G100R0F
A1R78	322-3248-00			RES,FXD,FILM:3.74K OHM,1%,0.2W,TC=T0TAPED &	91637	CCF50G37400F
A1R79	322-3356-00			RES,FXD,FILM:49.9K OHM,1%,0.2W,TC=TOMI	91637	CCF501G49901F
A1R80	322-3222-00			RES,FXD:METAL FILM:2K OHM,1%,0.2W,TC=100 PPM	91637	CCF501G20000F
A1R81	322-3121-00			RES,FXD:METAL FILM:178 OHM,1%,0.2W,TC=100 PPM	91637	CCF501G178R0F
A1R82	322-3260-00			RES,FXD,FILM:4.99K OHM,1%,0.2W,TC=T0TAPED &	91637	CCF501G49900F
A1R83	322-3289-07			RES,FXD,FILM:10K OHM,0.1%,0.2W,TC=T9,T&R	91637	CCF501C10001B
A1R84	322-3315-00			RES,FXD,FILM:18.7K OHM,1%,0.2W,TC=TOMI	91637	CCF501G18701F
A1R85	322-3385-00			RES,FXD:METAL FILM:100K OHM,1%,0.2W,TC=100 PPM	91637	CCF501G10002F
A1R86	308-0793-00			RES,FXD:0.51 OHM,5%,1WTC=150PPM/DEG C,MI	75042	BW20 .51OHM 5PE
A1R87	322-3034-00			RES,FXD:METAL FILM:22.1 OHM,1%,0.2W,TC=100 PPM	91637	CCF50-2-G22R10F
A1R88	322-3222-00			RES,FXD:METAL FILM:2K OHM,1%,0.2W,TC=100 PPM	91637	CCF501G20000F
A1R89	307-0746-00			RES,THERMAL:5 OHM,10%,7A/DEG C	15454	SG200-S STRAI
A1R90	305-0242-00			RES,FXD,CMPSN:2.4K OHM,5%,2W	11502	GF-3 OR GS-3 24
A1R91	306-0104-00			RES,FXD,CMPSN:100K OHM,10%,2W	24546	FP42 OR FP2 100
A1R92	306-0104-00			RES,FXD,CMPSN:100K OHM,10%,2W	24546	FP42 OR FP2 100
A1R93	322-3402-00			RES,FXD:METAL FILM:150K OHM,1%,0.2W,TC=100 PPM	91637	CCF50G15002F
A1R94	322-3402-00			RES,FXD:METAL FILM:150K OHM,1%,0.2W,TC=100 PPM	91637	CCF50G15002F
A1R95	322-3256-00			RES,FXD,FILM:4.53K OHM,1%,0.2W,TC=TOMI	91637	CCF50-2-G4531FT
A1R96	322-3356-00			RES,FXD,FILM:49.9K OHM,1%,0.2W,TC=TOMI	91637	CCF501G49901F
A1R97	322-3222-00			RES,FXD:METAL FILM:2K OHM,1%,0.2W,TC=100 PPM	91637	CCF501G20000F
A1R98	322-3289-07			RES,FXD,FILM:10K OHM,0.1%,0.2W,TC=T9,T&R	91637	CCF501C10001B
A1R99	311-2239-00			RES,VAR,TRMR: CERMET;100K OHM,20%,0.5W,0.197	TK2073	GF06UT2 104 M L
A1R101	322-3068-00			RES,FXD:METAL FILM:49.9 OHM,1%,0.2W,TC=100 PPM	91637	CCF501G49R90F
A1R102	308-0290-00			RES,FXD,WWW:8 OHM,5%,5W	91637	CW52-8R00J T/R
A1R103	322-3452-00			RES,FXD,FILM:499K OHM,1%,0.2W,TC=TOMI,SMALL	91637	CCF50-2-G4993FT
A1T1	120-1695-00			TRANSFORMER,PWR:HIGH VOLTAGE,FEEDBACK 3V, RESONANT 231V, 100V 1MA,2750V 3.3MA, 6.3V 86MA	75498	120-1695-00
A1T2	120-1945-00			TRANSFORMER,RF:PRI 8UH,2:7,ON-OFF,VERT MT,PC MT	OJR03	120-1945-00
A1T3	120-1944-00			TRANSFORMER,RF:PRI 88V,PRI 15V,SEC 40V AT0.385A,5V AT 2A,15V AT 0.80,IDED,PC MOUNT,1.45 X 1.7 X 1.17H	75498	129-2074-EC
A1TP1	214-4085-00			TERM,TEST POINT:0.070 ID,0.220 H,0.063 DIAP CB,0.015 X 0.032 BRASS,W/RED NYLON COLLAR	26364	104-01-02
A1TP2	214-4085-00			TERM,TEST POINT:0.070 ID,0.220 H,0.063 DIAP CB,0.015 X 0.032 BRASS,W/RED NYLON COLLAR	26364	104-01-02
A1U1	152-0900-00			MODULE,HV:7.5KVAC IN,15KVDC OUT,POTTED MODULE	51406	MSL2556
A1U2	156-0067-00			IC,LINEAR:BIPOLAR,OP-AMP	01295	UA741CP
A1U3	156-1225-00			IC,LINEAR:BIPOLAR,COMPTR;DUAL,OPEN COLL,300NS	01295	LM393P
A1U4	156-2761-01			IC,DIGITAL:HCMOS,MULTIVIBRATOR	OJR04	TC74HC221AP
A1U5	156-2524-00			IC,LINEAR:BIPOLAR,SW-REGULATOR CONTROLLER;PWM, CURRENT MODE,SINGLE TOTEM POLE OUTPUT	48726	UC3842N

1730-Series Replaceable Electrical Parts

Component Number	Tektronix Part Number	Serial / Assembly Number		Name & Description	Mfr. Code	Mfr. Part Number
		Effective	Discontinued			
A1VR1	156-1631-01			IC,LINEAR:BIPOLAR,VR:ADJUSTABLE,SHUNT,100MA,2.2%	01295	TL431CLPM
A1VR2	152-0195-00			DIODE,ZENER:5.1V,5%,0.4W	04713	MZ5523D
A1VR3	152-0195-00			DIODE,ZENER:5.1V,5%,0.4W	04713	MZ5523D
A1VR4	152-0149-00			DIODE,ZENER:10V,5%,0.4W	04713	1N961BRL
A1VR5	152-0287-00			DIODE,ZENER:110V,5%,0.4W	04713	1N986BRL
A1VR6	152-0287-00			DIODE,ZENER:110V,5%,0.4W	04713	1N986BRL
A1W1	131-0566-00			BUS,CONDUCTOR:DUMMY RES,0.094 OD X 0.225 L	24546	OMA0207
A1W2	131-0566-00			BUS,CONDUCTOR:DUMMY RES,0.094 OD X 0.225 L	24546	OMA0207
A1W3	131-0566-00			BUS,CONDUCTOR:DUMMY RES,0.094 OD X 0.225 L	24546	OMA0207
A1W4	131-0566-00			BUS,CONDUCTOR:DUMMY RES,0.094 OD X 0.225 L	24546	OMA0207
A2	670-9388-01			CIRCUIT BD ASSY:FRONT PNL	80009	670-9388-00
A2DS117	150-1290-00			DIO,OPTO:LED;ASSY,GRN,150-1109-00 IN 352-0779-00,A THREE PL HLDR	80009	150-1290-00
A2DS118	-----			(PART OF DS117)		
A2DS119	-----			(PART OF DS117)		
A2DS136	150-1290-00			DIO,OPTO:LED;ASSY,GRN,150-1109-00 IN 352-0779-00,A THREE PL HLDR	80009	150-1290-00
A2DS137	-----			(PART OF DS136)		
A2DS138	-----			(PART OF DS136)		
A2DS144	150-1286-00			DIO,OPTO:LED;ASSY,GRN,150-1109-00 IN 352-0779-00,A TWO PL HLDR	80009	150-1286-00
A2DS145	-----			(PART OF DS144)		
A2DS227	150-1284-00			LED ASSY:DIR:2 IN 2 GRN/RED	80009	150-1284-00
A2DS228	-----			(PART OF DS227)		
A2DS240	150-1290-00			DIO,OPTO:LED;ASSY,GRN,150-1109-00 IN 352-0779-00,A THREE PL HLDR	80009	150-1290-00
A2DS241	-----			(PART OF DS240)		
A2DS242	-----			(PART OF DS240)		
A2DS314	150-1290-00			DIO,OPTO:LED;ASSY,GRN,150-1109-00 IN 352-0779-00,A THREE PL HLDR	80009	150-1290-00
A2DS315	-----			(PART OF DS314)		
A2DS316	-----			(PART OF DS314)		
A2DS327	150-1290-00			DIO,OPTO:LED;ASSY,GRN,150-1109-00 IN 352-0779-00,A THREE PL HLDR	80009	150-1290-00
A2DS328	-----			(PART OF DS327)		
A2DS329	-----			(PART OF DS327)		
A2DS340	150-1286-00			DIO,OPTO:LED;ASSY,GRN,150-1109-00 IN 352-0779-00,A TWO PL HLDR	80009	150-1286-00
A2DS341	-----			(PART OF DS340)		
A2P107	175-9773-01			CA ASSY,SP,ELEC:34,26 AWG,5.0 L	TK1462	ORDER BY DESCR
A2R212	311-2540-00			RES,VAR,NONWW:PNL,20K OHM,10%,0.5W LINEAR	12697	CM45210
				ATTACHED PARTS		
	366-1701-01			KNOB:GY,0.127 ID X 0.392 OD X 0.4 H	80009	366-1701-01
	214-4725-00			SPRING:COMPRESSION SPRING,0.026,302 STAINLESS STEEL,0.313,+/-,0.0A0	8X345	214-4725-00
				END ATTACHED PARTS		
A2R245	311-2321-00			RES,VAR,WW:CLAROSTAT,3 TURN POT	80009	311-2321-00
				MOUNTING PARTS		
	210-0583-00			NUT,PL,HEX:0.25-32 X 0.312,BRS CD PL	73743	2X-20319-402
	210-1435-00			WSHR,FLT:0.254 X 0.311 X 0.016,SST	86928	5710-56-15P
	366-1701-01			KNOB:GY,0.127 ID X 0.392 OD X 0.4 H	80009	366-1701-01
				END MOUNTING PARTS		
A2R412	311-2540-00			RES,VAR,NONWW:PNL,20K OHM,10%,0.5W LINEAR	12697	CM45210
				ATTACHED PARTS		
	366-1701-01			KNOB:GY,0.127 ID X 0.392 OD X 0.4 H	80009	366-1701-01
	214-4725-00			SPRING:COMPRESSION SPRING,0.026,302 STAINLESS STEEL,0.313,+/-,0.0A0	8X345	214-4725-00
				END ATTACHED PARTS		

1730-Series Replaceable Electrical Parts

Component Number	Tektronix Part Number	Serial / Assembly Number		Name & Description	Mfr. Code	Mfr. Part Number
		Effective	Discontinued			
A2R429	311-2540-00			RES,VAR,NONWW:P.NL,20K OHM,10%,0.5W LINEAR *ATTACHED PARTS*	12697	CM45210
	366-1701-01			KNOB:GY,0.127 ID X 0.392 OD X 0.4 H	80009	366-1701-01
	214-4725-00			SPRING:COMPRESSION SPRING,0.026,302 STAINLESS STEEL,0.313,+/-,0.0A0 *END ATTACHED PARTS*	8X345	214-4725-00
A2R435	311-2321-00			RES,VAR,WW:CLAROSTAT,3 TURN POT *MOUNTING PARTS*	80009	311-2321-00
	210-0583-00			NUT,PL,HEX:0.25-32 X 0.312,BRS CD PL	73743	2X-20319-402
	210-1435-00			WSHR,FLT:0.254 X 0.311 X 0.016,SST	86928	5710-56-15P
	366-1701-01			KNOB:GY,0.127 ID X 0.392 OD X 0.4 H *END MOUNTING PARTS*	80009	366-1701-01
A2R443	311-2540-00			RES,VAR,NONWW:P.NL,20K OHM,10%,0.5W LINEAR *ATTACHED PARTS*	12697	CM45210
	366-1701-01			KNOB:GY,0.127 ID X 0.392 OD X 0.4 H	80009	366-1701-01
	214-4725-00			SPRING:COMPRESSION SPRING,0.026,302 STAINLESS STEEL,0.313,+/-,0.0A0 *END ATTACHED PARTS*	8X345	214-4725-00
A2S112	260-2300-00			SW,SIG:SPST;PUSH,MOM,NO,W/GND TERM,MNL INSERTION,100 GRAMS,SIL,SLD:B3F1152 *ATTACHED PARTS*	34361	B3F1152
	366-0616-00			PUSH BTN:0.585 X 0.3 X 0.150 *END ATTACHED PARTS*	80009	366-0616-00
A2S130	260-2300-00			SW,SIG:SPST;PUSH,MOM,NO,W/GND TERM,MNL INSERTION,100 GRAMS,SIL,SLD:B3F1152 *ATTACHED PARTS*	34361	B3F1152
	366-0616-00			PUSH BTN:0.585 X 0.3 X 0.150 *END ATTACHED PARTS*	80009	366-0616-00
A2S145	260-2300-00			SW,SIG:SPST;PUSH,MOM,NO,W/GND TERM,MNL INSERTION,100 GRAMS,SIL,SLD:B3F1152 *ATTACHED PARTS*	34361	B3F1152
	366-0616-00			PUSH BTN:0.585 X 0.3 X 0.150 *END ATTACHED PARTS*	80009	366-0616-00
A2S222	260-2300-00			SW,SIG:SPST;PUSH,MOM,NO,W/GND TERM,MNL INSERTION,100 GRAMS,SIL,SLD:B3F1152 *ATTACHED PARTS*	34361	B3F1152
	366-0616-00			PUSH BTN:0.585 X 0.3 X 0.150 *END ATTACHED PARTS*	80009	366-0616-00
A2S235	260-2300-00			SW,SIG:SPST;PUSH,MOM,NO,W/GND TERM,MNL INSERTION,100 GRAMS,SIL,SLD:B3F1152 *ATTACHED PARTS*	34361	B3F1152
	366-0616-00			PUSH BTN:0.585 X 0.3 X 0.150 *END ATTACHED PARTS*	80009	366-0616-00
A2S309	260-2300-00			SW,SIG:SPST;PUSH,MOM,NO,W/GND TERM,MNL INSERTION,100 GRAMS,SIL,SLD:B3F1152 *ATTACHED PARTS*	34361	B3F1152
	366-0616-00			PUSH BTN:0.585 X 0.3 X 0.150 *END ATTACHED PARTS*	80009	366-0616-00
A2S322	260-2300-00			SW,SIG:SPST;PUSH,MOM,NO,W/GND TERM,MNL INSERTION,100 GRAMS,SIL,SLD:B3F1152 *ATTACHED PARTS*	34361	B3F1152
	366-0616-00			PUSH BTN:0.585 X 0.3 X 0.150 *END ATTACHED PARTS*	80009	366-0616-00
A2S335	260-2300-00			SW,SIG:SPST;PUSH,MOM,NO,W/GND TERM,MNL INSERTION,100 GRAMS,SIL,SLD:B3F1152 *ATTACHED PARTS*	34361	B3F1152
	366-0616-00			PUSH BTN:0.585 X 0.3 X 0.150 *END ATTACHED PARTS*	80009	366-0616-00

1730-Series Replaceable Electrical Parts

Component Number	Tektronix Part Number	Serial / Assembly Number		Name & Description	Mfr. Code	Mfr. Part Number
		Effective	Discontinued			
A2S509	260-2300-00			SW,SIG:SPST:PUSH,MOM,NO,W/GND TERM,MNL INSERTION,100 GRAMS,SIL,SLD;B3F1152	34361	B3F1152
	366-0616-00			*ATTACHED PARTS* PUSH BTN:0.585 X 0.3 X 0.150	80009	366-0616-00
				END ATTACHED PARTS		
A2S521	260-2300-00			SW,SIG:SPST:PUSH,MOM,NO,W/GND TERM,MNL INSERTION,100 GRAMS,SIL,SLD;B3F1152	34361	B3F1152
	366-0616-00			*ATTACHED PARTS* PUSH BTN:0.585 X 0.3 X 0.150	80009	366-0616-00
				END ATTACHED PARTS		
A2S534	260-2300-00			SW,SIG:SPST:PUSH,MOM,NO,W/GND TERM,MNL INSERTION,100 GRAMS,SIL,SLD;B3F1152	34361	B3F1152
	366-0616-00			*ATTACHED PARTS* PUSH BTN:0.585 X 0.3 X 0.150	80009	366-0616-00
				END ATTACHED PARTS		
A3	672-1229-14			CIRCUIT BD ASSY:MAIN (1730, 1731 ONLY)	80009	672-1229-14
A3	672-1266-15			CIRCUIT BD ASSY:MAIN (1735 ONLY)	80009	672-1266-15
A3	672-0225-13			CIRCUIT BD ASSY:MAIN (1731 PM ONLY)	80009	672-0225-13
				ATTACHED PARTS		
	174-0334-00			CA ASSY,RF:50 OHM COAX,5.25 L,9-N	80009	174-0334-00
	337-0607-00			PLT,ELEC SHLD:CKT BD (QUANTITY 3)	80009	337-0607-00
				END ATTACHED PARTS		
A3C87	281-0776-00			CAP,FXD,CER:MLC:120PF,5%,100V,0.100 X 0.170;AXIAL,MI	04222	SA102A121JAA
A3C88	281-0823-00			CAP,FXD,CER DI:470PF,10%,50V	04222	SA101A471KAA
A3C89	290-0974-00			CAP,FXD,ELCTL:10UF,20%,50VDC	55680	UVV1H100MAA
A3C90	290-0974-00			CAP,FXD,ELCTL:10UF,20%,50VDC	55680	UVV1H100MAA
A3C91	281-0537-00			CAP,FXD,CER:MLC:0.68PF,20%,500V,0.170 X 0.187;AXIAL	80009	281-0537-00
A3C92	281-0826-00			CAP,FXD,CER:MLC:2200PF,10%,100V,0.100 X 0.170;AXIAL	04222	SA101C222KAA
A3C93	281-0762-00			CAP,FXD,CER DI:27PF,20%,100V	80009	281-0762-00
A3C94	281-0762-00			CAP,FXD,CER DI:27PF,20%,100V	80009	281-0762-00
A3C95	281-0764-00			CAP,FXD,CER DI:82PF,5%,100V	04222	SA102A820JAA
A3C96	281-0788-00			CAP,FXD,CER:MLC:470PF,10%,100V,0.100 X 0.170;AXIAL,MI	04222	SA102C471KAA
A3C97	281-0799-00			CAP,FXD,CER DI:62PF,2%,100V	80009	281-0799-00
A3C98	281-0775-01			CAP,FXD,CER:MCL:0.1UF,20%,50V,Z5U,0.170 X 0.100;AXIAL	04222	SA105E104MAA
A3C129	290-0839-00			CAP,FXD,ELCTL:330UF,+50-20%,35V	55680	TLB1V331MCA
A3C134	281-0773-00			CAP,FXD,CER:MLC:0.01UF,10%,100V,SAF,0.100 X 0.170	80009	281-0773-00
A3C135	281-0775-01			CAP,FXD,CER:MCL:0.1UF,20%,50V,Z5U,0.170 X 0.100;AXIAL	04222	SA105E104MAA
A3C146	290-1311-00			CAP,FXD,ALUM:10UF,20%,50V,5 X 11MM;5000 HRS,RDL	80009	290-1311-00
A3C152	281-0775-01			CAP,FXD,CER:MCL:0.1UF,20%,50V,Z5U,0.170 X 0.100;AXIAL	04222	SA105E104MAA
A3C165	281-0770-00			CAP,FXD,CER DI:1000PF,20%,100V	04222	SA101C102MAA
A3C167	290-1311-00			CAP,FXD,ALUM:10UF,20%,50V,5 X 11MM;5000 HRS,RDL	80009	290-1311-00
A3C168	290-1311-00			CAP,FXD,ALUM:10UF,20%,50V,5 X 11MM;5000 HRS,RDL	80009	290-1311-00
A3C169	290-1311-00			CAP,FXD,ALUM:10UF,20%,50V,5 X 11MM;5000 HRS,RDL	80009	290-1311-00
A3C195	281-0302-00			CAP,VAR,PLSTC:1.2-4PF,100V	52769	GXL4R000
A3C196	281-0770-00			CAP,FXD,CER DI:1000PF,20%,100V	04222	SA101C102MAA
A3C197	290-0848-00			CAP,FXD,ALUM:47UF,+100%-20%,16V,NONPOLAR, 0.681X0.414;RDL	80009	290-0848-00
A3C198	281-0756-00			CAP,FXD,CER:MLC:2.2PF,+/-0.5PF,200V,0.100 X 0.170;AXIAL	04222	SA102A2R2DAA
A3C199	281-0903-00			CAP,FXD,CER DI:3.9PF,100V	80009	281-0903-00
A3C225	281-0775-01			CAP,FXD,CER:MCL:0.1UF,20%,50V,Z5U,0.170 X 0.100;AXIAL	04222	SA105E104MAA
A3C226	281-0775-01			CAP,FXD,CER:MCL:0.1UF,20%,50V,Z5U,0.170 X 0.100;AXIAL	04222	SA105E104MAA
A3C231	281-0775-01			CAP,FXD,CER:MCL:0.1UF,20%,50V,Z5U,0.170 X 0.100;AXIAL	04222	SA105E104MAA
A3C248	281-0775-01			CAP,FXD,CER:MCL:0.1UF,20%,50V,Z5U,0.170 X 0.100;AXIAL	04222	SA105E104MAA
A3C249	281-0775-01			CAP,FXD,CER:MCL:0.1UF,20%,50V,Z5U,0.170 X 0.100;AXIAL	04222	SA105E104MAA
A3C254	281-0775-01			CAP,FXD,CER:MCL:0.1UF,20%,50V,Z5U,0.170 X 0.100;AXIAL	04222	SA105E104MAA
A3C263	281-0775-01			CAP,FXD,CER:MCL:0.1UF,20%,50V,Z5U,0.170 X 0.100;AXIAL	04222	SA105E104MAA

1730-Series Replaceable Electrical Parts

Component Number	Tektronix Part Number	Serial / Assembly Number		Name & Description	Mfr. Code	Mfr. Part Number
		Effective	Discontinued			
A3C264	281-0775-01			CAP,FXD,CER:MCL:0.1UF,20%,50V,Z5U,0.170 X 0.100;AXIAL	04222	SA105E104MAA
A3C267	290-1311-00			CAP,FXD,ALUM:10UF,20%,50V,5 X 11MM;5000 HRS,RDL	80009	290-1311-00
A3C269	281-0770-00			CAP,FXD,CER DI:1000PF,20%,100V	04222	SA101C102MAA
A3C272	281-0775-01			CAP,FXD,CER:MCL:0.1UF,20%,50V,Z5U,0.170 X 0.100;AXIAL	04222	SA105E104MAA
A3C294	281-0819-00			CAP,FXD,CER:MLC:33 PF,5%,50V,0.100 X 0.170;AXIAL,MI	04222	SA102A330JAA
A3C298	281-0775-01			CAP,FXD,CER:MCL:0.1UF,20%,50V,Z5U,0.170 X 0.100;AXIAL	04222	SA105E104MAA
A3C321	281-0775-01			CAP,FXD,CER:MCL:0.1UF,20%,50V,Z5U,0.170 X 0.100;AXIAL	04222	SA105E104MAA
A3C322	281-0775-01			CAP,FXD,CER:MCL:0.1UF,20%,50V,Z5U,0.170 X 0.100;AXIAL	04222	SA105E104MAA
A3C324	290-0748-00			CAP,FXD,ELCTL:10UF,+50-20%,25VVDC	24165	501D106F063LL4
A3C331	281-0770-00			CAP,FXD,CER DI:1000PF,20%,100V	04222	SA101C102MAA
A3C363	281-0775-01			CAP,FXD,CER:MCL:0.1UF,20%,50V,Z5U,0.170 X 0.100;AXIAL	04222	SA105E104MAA
A3C367	281-0810-00			CAP,FXD,CER:MLC:5.6PF,+/-0.5PF,100V,0.100 X 0.170;AXIAL	04222	SA101A5R6DAA
A3C368	281-0302-00			CAP,VAR,PLSTC:1.2-4PF,100V	52769	GXL4R000
A3C372	281-0158-00			CAP,VAR,CER DI:7-45PF,100VVDC SUBMIN CER DISC TOP ADJ	80009	281-0158-00
A3C374	281-0775-01			CAP,FXD,CER:MCL:0.1UF,20%,50V,Z5U,0.170 X 0.100;AXIAL	04222	SA105E104MAA
A3C375	281-0775-01			CAP,FXD,CER:MCL:0.1UF,20%,50V,Z5U,0.170 X 0.100;AXIAL	04222	SA105E104MAA
A3C376	290-1311-00			CAP,FXD,ALUM:10UF,20%,50V,5 X 11MM;5000 HRS,RDL	80009	290-1311-00
A3C377	281-0775-01			CAP,FXD,CER:MCL:0.1UF,20%,50V,Z5U,0.170 X 0.100;AXIAL	04222	SA105E104MAA
A3C384	283-0625-01			CAP,FXD,MICA DI:220PF,1%,500V	09023	CDA10FD221F03
A3C385	281-0814-00			CAP,FXD,CER:MLC:100 PF,10%,100V,0.100 X 0.170;AXIAL,MI	80009	281-0814-00
A3C387	283-0625-01			CAP,FXD,MICA DI:220PF,1%,500V	09023	CDA10FD221F03
A3C388	281-0775-01			CAP,FXD,CER:MCL:0.1UF,20%,50V,Z5U,0.170 X 0.100;AXIAL	04222	SA105E104MAA
A3C389	283-0639-00			CAP,FXD,MICA DI:56PF,1%,500V	80009	283-0639-00
A3C392	281-0960-00			CAP,FXD,CER:MLC:10PF,+/- .25PF,200V,NPO, .170X.100	80009	281-0960-00
A3C393	281-0960-00			CAP,FXD,CER:MLC:10PF,+/- .25PF,200V,NPO, .170X.100	80009	281-0960-00
A3C394	281-0770-00			CAP,FXD,CER DI:1000PF,20%,100V	04222	SA101C102MAA
A3C395	281-0775-01			CAP,FXD,CER:MCL:0.1UF,20%,50V,Z5U,0.170 X 0.100;AXIAL	04222	SA105E104MAA
A3C396	281-0775-01			CAP,FXD,CER:MCL:0.1UF,20%,50V,Z5U,0.170 X 0.100;AXIAL	04222	SA105E104MAA
A3C398	281-0815-00			CAP,FXD,CER:MLC:0.027UF,20%,50V,0.100 X 0.260;AXIAL,MI	04222	SA205C273MAA
A3C428	281-0775-01			CAP,FXD,CER:MCL:0.1UF,20%,50V,Z5U,0.170 X 0.100;AXIAL	04222	SA105E104MAA
A3C430	281-0775-01			CAP,FXD,CER:MCL:0.1UF,20%,50V,Z5U,0.170 X 0.100;AXIAL	04222	SA105E104MAA
A3C431	281-0763-00			CAP,FXD,CER:MLC:47PF,10%,100V,0.100 X 0.170;AXIAL,MI	04222	SA102A470KAA
A3C448	285-1133-00			CAP,FXD,PLSTC:0.33MF,1%,100V	80009	285-1133-00
A3C453	283-0655-00			CAP,FXD,MICA DI:3300PF,1%,500V	80009	283-0655-00
A3C468	281-0775-01			CAP,FXD,CER:MCL:0.1UF,20%,50V,Z5U,0.170 X 0.100;AXIAL	04222	SA105E104MAA
A3C473	281-0770-00			CAP,FXD,CER DI:1000PF,20%,100V	04222	SA101C102MAA
A3C476	283-0642-00			CAP,FXD,MICA DI:33PF,2%,500V,0.370 X 0.340;RDL	00853	D105E330G0
A3C481	281-0775-01			CAP,FXD,CER:MCL:0.1UF,20%,50V,Z5U,0.170 X 0.100;AXIAL	04222	SA105E104MAA
A3C484	281-0775-01			CAP,FXD,CER:MCL:0.1UF,20%,50V,Z5U,0.170 X 0.100;AXIAL	04222	SA105E104MAA
A3C487	281-0775-01			CAP,FXD,CER:MCL:0.1UF,20%,50V,Z5U,0.170 X 0.100;AXIAL	04222	SA105E104MAA
A3C488	281-0775-01			CAP,FXD,CER:MCL:0.1UF,20%,50V,Z5U,0.170 X 0.100;AXIAL	04222	SA105E104MAA
A3C493	281-0775-01			CAP,FXD,CER:MCL:0.1UF,20%,50V,Z5U,0.170 X 0.100;AXIAL	04222	SA105E104MAA
A3C495	281-0775-01			CAP,FXD,CER:MCL:0.1UF,20%,50V,Z5U,0.170 X 0.100;AXIAL	04222	SA105E104MAA
A3C496	281-0815-00			CAP,FXD,CER:MLC:0.027UF,20%,50V,0.100 X 0.260;AXIAL,MI	04222	SA205C273MAA
A3C497	281-0770-00			CAP,FXD,CER DI:1000PF,20%,100V	04222	SA101C102MAA
A3C498	281-0775-01			CAP,FXD,CER:MCL:0.1UF,20%,50V,Z5U,0.170 X 0.100;AXIAL	04222	SA105E104MAA
A3C544	281-0773-00			CAP,FXD,CER:MLC:0.01UF,10%,100V,SAF,0.100 X 0.170	80009	281-0773-00
A3C546	281-0775-01			CAP,FXD,CER:MCL:0.1UF,20%,50V,Z5U,0.170 X 0.100;AXIAL	04222	SA105E104MAA
A3C547	281-0767-00			CAP,FXD,CER:MLC:330PF,20%,100V,0.100 X 0.170;AXIAL,MI	04222	SA102C331MAA
A3C548	281-0763-00			CAP,FXD,CER:MLC:47PF,10%,100V,0.100 X 0.170;AXIAL,MI	04222	SA102A470KAA
A3C549	281-0814-00			CAP,FXD,CER:MLC:100 PF,10%,100V,0.100 X 0.170;AXIAL,MI	80009	281-0814-00
A3C555	281-0775-01			CAP,FXD,CER:MCL:0.1UF,20%,50V,Z5U,0.170 X 0.100;AXIAL	04222	SA105E104MAA
A3C557	281-0811-00			CAP,FXD,CER:MLC:10PF,10%,100V,0.100 X 0.170;AXIAL,MI	04222	SA102A100KAA
A3C569	281-0816-00			CAP,FXD,CER:MLC:82 PF,5%,100V,0.100 X 0.170;AXIAL,MI	80009	281-0816-00
A3C570	281-0775-01			CAP,FXD,CER:MCL:0.1UF,20%,50V,Z5U,0.170 X 0.100;AXIAL	04222	SA105E104MAA
A3C579	290-1311-00			CAP,FXD,ALUM:10UF,20%,50V,5 X 11MM;5000 HRS,RDL	80009	290-1311-00
A3C595	281-0819-00			CAP,FXD,CER:MLC:33 PF,5%,50V,0.100 X 0.170;AXIAL,MI	04222	SA102A330JAA

1730-Series Replaceable Electrical Parts

Component Number	Tektronix Part Number	Serial / Assembly Number		Name & Description	Mfr. Code	Mfr. Part Number
		Effective	Discontinued			
A3C596	281-0756-00			CAP,FXD,CER:MLC;2.2PF,+/-0.5PF,200V,0.100 X 0.170;AXIAL	04222	SA102A2R2DAA
A3C597	281-0770-00			CAP,FXD,CER DI:1000PF,20%,100V	04222	SA101C102MAA
A3C606	281-0819-00			CAP,FXD,CER:MLC;33 PF,5%,50V,0.100 X 0.170;AXIAL,MI	04222	SA102A330JAA
A3C607	281-0819-00			CAP,FXD,CER:MLC;33 PF,5%,50V,0.100 X 0.170;AXIAL,MI	04222	SA102A330JAA
A3C627	281-0775-01			CAP,FXD,CER:MCL;0.1UF,20%,50V,Z5U,0.170 X 0.100;AXIAL	04222	SA105E104MAA
A3C629	281-0775-01			CAP,FXD,CER:MCL;0.1UF,20%,50V,Z5U,0.170 X 0.100;AXIAL	04222	SA105E104MAA
A3C631	281-0775-01			CAP,FXD,CER:MCL;0.1UF,20%,50V,Z5U,0.170 X 0.100;AXIAL	04222	SA105E104MAA
A3C641	283-0634-00			CAP,FXD,MICA DI:65PF,1%,100V	80009	283-0634-00
A3C643	283-0645-00			CAP,FXD,MICA DI:790PF,1%,300V	80009	283-0645-00
A3C663	281-0903-00			CAP,FXD,CER DI:3.9PF,100V	80009	281-0903-00
A3C676	281-0770-00			CAP,FXD,CER DI:1000PF,20%,100V	04222	SA101C102MAA
A3C681	281-0775-01			CAP,FXD,CER:MCL;0.1UF,20%,50V,Z5U,0.170 X 0.100;AXIAL	04222	SA105E104MAA
A3C683	281-0158-00			CAP,VAR,CER DI:7-45PF,100WVDC SUBMIN CER DISC TOP ADJ	80009	281-0158-00
A3C693	281-0797-00			CAP,FXD,CER:MLC;15PF,10%,100V,SAF ,0.100 X 0.170	80009	281-0797-00
A3C694	281-0182-00			CAP,VAR,PLSTC:1.8-10PF,300V	19701	2805D1R810BH03FO
A3C695	281-0797-00			CAP,FXD,CER:MLC;15PF,10%,100V,SAF ,0.100 X 0.170	80009	281-0797-00
A3C696	281-0302-00			CAP,VAR,PLSTC:1.2-4PF,100V	52769	GXL4R000
A3C697	290-0848-00			CAP,FXD,ALUM:47UF,+100%-20%,16V,NONPOLAR, 0.681X0.414;RDL	80009	290-0848-00
A3C699	281-0895-00			CAP,FXD,CER DI:6.8PF,100VDC	80009	281-0895-00
A3C722	290-0748-00			CAP,FXD,ELCTL:10UF,+50-20%,25WVDC	24165	501D106F063LL4
A3C728	281-0775-01			CAP,FXD,CER:MCL;0.1UF,20%,50V,Z5U,0.170 X 0.100;AXIAL	04222	SA105E104MAA
A3C740	281-0773-00			CAP,FXD,CER:MLC;0.01UF,10%,100V,SAF,0.100 X 0.170	80009	281-0773-00
A3C743	281-0773-00			CAP,FXD,CER:MLC;0.01UF,10%,100V,SAF,0.100 X 0.170	80009	281-0773-00
A3C745	281-0773-00			CAP,FXD,CER:MLC;0.01UF,10%,100V,SAF,0.100 X 0.170	80009	281-0773-00
A3C746	281-0813-00			CAP,FXD,CER:MLC;0.047UF,20%,50V,0.100 X 0.170;AXIAL,MI	04222	SA105E473MAA
A3C752	281-0775-01			CAP,FXD,CER:MCL;0.1UF,20%,50V,Z5U,0.170 X 0.100;AXIAL	04222	SA105E104MAA
A3C775	281-0158-00			CAP,VAR,CER DI:7-45PF,100WVDC SUBMIN CER DISC TOP ADJ	80009	281-0158-00
A3C776	281-0786-00			CAP,FXD,CER:MLC;150PF,10%,100V,0.100 X 0.170;AXIAL,MI	04222	SA101A151KAA
A3C777	281-0158-00			CAP,VAR,CER DI:7-45PF,100WVDC SUBMIN CER DISC TOP ADJ	80009	281-0158-00
A3C778	281-0158-00			CAP,VAR,CER DI:7-45PF,100WVDC SUBMIN CER DISC TOP ADJ	80009	281-0158-00
A3C779	283-0629-00			CAP,FXD,MICA DI:62PF,1%,500V	80009	283-0629-00
A3C780	283-0677-00			CAP,FXD,MICA DI:82PF,1%,500V	80009	283-0677-00
A3C781	283-0629-00			CAP,FXD,MICA DI:62PF,1%,500V	80009	283-0629-00
A3C782	283-0639-00			CAP,FXD,MICA DI:56PF,1%,500V	80009	283-0639-00
A3C783	281-0123-00			CAP,VAR,CER DI:5-25PF,100V	59660	518-000A5-25
A3C784	281-0123-00			CAP,VAR,CER DI:5-25PF,100V	59660	518-000A5-25
A3C805	281-0775-01			CAP,FXD,CER:MCL;0.1UF,20%,50V,Z5U,0.170 X 0.100;AXIAL	04222	SA105E104MAA
A3C809	281-0775-01			CAP,FXD,CER:MCL;0.1UF,20%,50V,Z5U,0.170 X 0.100;AXIAL	04222	SA105E104MAA
A3C825	281-0775-01			CAP,FXD,CER:MCL;0.1UF,20%,50V,Z5U,0.170 X 0.100;AXIAL	04222	SA105E104MAA
A3C848	283-0634-00			CAP,FXD,MICA DI:65PF,1%,100V	80009	283-0634-00
A3C853	281-0773-00			CAP,FXD,CER:MLC;0.01UF,10%,100V,SAF,0.100 X 0.170	80009	281-0773-00
A3C854	281-0810-00			CAP,FXD,CER:MLC;5.6PF,+/-0.5PF,100V,0.100 X 0.170;AXIAL	04222	SA101A5R6DAA
A3C859	281-0775-01			CAP,FXD,CER:MCL;0.1UF,20%,50V,Z5U,0.170 X 0.100;AXIAL	04222	SA105E104MAA
A3C861	281-0811-00			CAP,FXD,CER:MLC;10PF,10%,100V,0.100 X 0.170;AXIAL,MI	04222	SA102A100KAA
A3C865	281-0775-01			CAP,FXD,CER:MCL;0.1UF,20%,50V,Z5U,0.170 X 0.100;AXIAL	04222	SA105E104MAA
A3C871	281-0762-00			CAP,FXD,CER DI:27PF,20%,100V	80009	281-0762-00
A3C872	290-0782-02			CAP,FXD,ELCTL:4.7UF,+75-10%,35VDC	55680	UVX1V4R7MAA1TD
A3C873	281-0810-00			CAP,FXD,CER:MLC;5.6PF,+/-0.5PF,100V,0.100 X 0.170;AXIAL	04222	SA101A5R6DAA
A3C887	281-0815-00			CAP,FXD,CER:MLC;0.027UF,20%,50V,0.100 X 0.260;AXIAL,MI	04222	SA205C273MAA
A3C893	281-0775-01			CAP,FXD,CER:MCL;0.1UF,20%,50V,Z5U,0.170 X 0.100;AXIAL	04222	SA105E104MAA
A3C898	281-0775-01			CAP,FXD,CER:MCL;0.1UF,20%,50V,Z5U,0.170 X 0.100;AXIAL	04222	SA105E104MAA
A3C906	290-0183-00			CAP,FXD,TANT:DRY;1UF,10%,35V,TANT OXIDE,0.151 X 0.317;AXIAL,MI	05397	T3228105K035AS

1730-Series Replaceable Electrical Parts

Component Number	Tektronix Part Number	Serial / Assembly Number		Name & Description	Mfr. Code	Mfr. Part Number
		Effective	Discontinued			
A3C907	290-0183-00			CAP,FXD,TANT:DRY;1UF,10%,35V,TANT OXIDE,0.151 X 0.317;AXIAL,MI	05397	T3228105K035AS
A3C938	281-0775-01			CAP,FXD,CER:MCL;0.1UF,20%,50V,Z5U,0.170 X 0.100;AXIAL	04222	SA105E104MAA
A3C944	283-0660-00			CAP,FXD,MICA DI:510PF,2%,500V	80009	283-0660-00
A3C945	290-1311-00			CAP,FXD,ALUM:10UF,20%,50V,5 X 11MM;5000 HRS,RDL	80009	290-1311-00
A3C950	283-0634-00			CAP,FXD,MICA DI:65PF,1%,100V	80009	283-0634-00
A3C952	281-0775-01			CAP,FXD,CER:MCL;0.1UF,20%,50V,Z5U,0.170 X 0.100;AXIAL	04222	SA105E104MAA
A3C953	281-0302-00			CAP,VAR,PLSTC:1.2-4PF,100V	52769	GXL4R000
A3C964	281-0775-01			CAP,FXD,CER:MCL;0.1UF,20%,50V,Z5U,0.170 X 0.100;AXIAL	04222	SA105E104MAA
A3C974	281-0756-00			CAP,FXD,CER:MLC;2.2PF,+/-0.5PF,200V,0.100 X 0.170;AXIAL	04222	SA102A2R2DAA
A3C976	281-0762-00			CAP,FXD,CER DI:27PF,20%,100V	80009	281-0762-00
A3C989	281-0762-00			CAP,FXD,CER DI:27PF,20%,100V	80009	281-0762-00
A3C998	290-0183-00			CAP,FXD,TANT:DRY;1UF,10%,35V,TANT OXIDE,0.151 X 0.317;AXIAL,MI	05397	T3228105K035AS
A3CR99	152-0141-02			DIO,SIG:ULTRA FAST;40V,150MA,4NS,2PF;1N4152,DO-35	80009	152-0141-02
A3CR146	152-0400-00			DIO,RECT:FAST RCVRY;400V,1A,200NS;1N4936,DO-41,T&R	80009	152-0400-00
A3CR154	152-0141-02			DIO,SIG:ULTRA FAST;40V,150MA,4NS,2PF;1N4152,DO-35	80009	152-0141-02
A3CR235	152-0141-02			DIO,SIG:ULTRA FAST;40V,150MA,4NS,2PF;1N4152,DO-35	80009	152-0141-02
A3CR238	152-0141-02			DIO,SIG:ULTRA FAST;40V,150MA,4NS,2PF;1N4152,DO-35	80009	152-0141-02
A3CR246	152-0141-02			DIO,SIG:ULTRA FAST;40V,150MA,4NS,2PF;1N4152,DO-35	80009	152-0141-02
A3CR247	152-0141-02			DIO,SIG:ULTRA FAST;40V,150MA,4NS,2PF;1N4152,DO-35	80009	152-0141-02
A3CR248	152-0141-02			DIO,SIG:ULTRA FAST;40V,150MA,4NS,2PF;1N4152,DO-35	80009	152-0141-02
A3CR254	152-0141-02			DIO,SIG:ULTRA FAST;40V,150MA,4NS,2PF;1N4152,DO-35	80009	152-0141-02
A3CR255	152-0141-02			DIO,SIG:ULTRA FAST;40V,150MA,4NS,2PF;1N4152,DO-35	80009	152-0141-02
A3CR256	152-0141-02			DIO,SIG:ULTRA FAST;40V,150MA,4NS,2PF;1N4152,DO-35	80009	152-0141-02
A3CR257	152-0400-00			DIO,RECT:FAST RCVRY;400V,1A,200NS;1N4936,DO-41,T&R	80009	152-0400-00
A3CR264	152-0066-00			DIO,RECT:400V,1A,IFSM=30A,1.2VF,2US;GP10G/1N5060,T&R,SAF CONT	05828	GP10G-020
A3CR268	152-0066-00			DIO,RECT:400V,1A,IFSM=30A,1.2VF,2US;GP10G/1N5060,T&R,SAF CONT	05828	GP10G-020
A3CR272	152-0066-00			DIO,RECT:400V,1A,IFSM=30A,1.2VF,2US;GP10G/1N5060,T&R,SAF CONT	05828	GP10G-020
A3CR280	152-0307-00			DIO,SIG:ULTRA FAST;100V,4.0NS,1.5PF,DUAL COM-CATH;MSD6100,TO-92	04713	SSD1150
A3CR326	152-0141-02			DIO,SIG:ULTRA FAST;40V,150MA,4NS,2PF;1N4152,DO-35	80009	152-0141-02
A3CR334	152-0141-02			DIO,SIG:ULTRA FAST;40V,150MA,4NS,2PF;1N4152,DO-35	80009	152-0141-02
A3CR364	152-0066-00			DIO,RECT:400V,1A,IFSM=30A,1.2VF,2US;GP10G/1N5060	05828	GP10G-020
A3CR380	152-0501-01			DIO,SIG:FAST RCVRY;70V,200MA,100NS,COM-ANODE;MSD6150,TO-92,TR	80009	152-0501-01
A3CR459	152-0141-02			DIO,SIG:ULTRA FAST;40V,150MA,4NS,2PF;1N4152,DO-35	80009	152-0141-02
A3CR462	152-0141-02			DIO,SIG:ULTRA FAST;40V,150MA,4NS,2PF;1N4152,DO-35	80009	152-0141-02
A3CR463	152-0141-02			DIO,SIG:ULTRA FAST;40V,150MA,4NS,2PF;1N4152,DO-35	80009	152-0141-02
A3CR476	152-0141-02			DIO,SIG:ULTRA FAST;40V,150MA,4NS,2PF;1N4152,DO-35	80009	152-0141-02
A3CR534	152-0141-02			DIO,SIG:ULTRA FAST;40V,150MA,4NS,2PF;1N4152,DO-35	80009	152-0141-02
A3CR540	152-0141-02			DIO,SIG:ULTRA FAST;40V,150MA,4NS,2PF;1N4152,DO-35	80009	152-0141-02
A3CR541	152-0141-02			DIO,SIG:ULTRA FAST;40V,150MA,4NS,2PF;1N4152,DO-35	80009	152-0141-02
A3CR542	152-0141-02			DIO,SIG:ULTRA FAST;40V,150MA,4NS,2PF;1N4152,DO-35	80009	152-0141-02
A3CR543	152-0141-02			DIO,SIG:ULTRA FAST;40V,150MA,4NS,2PF;1N4152,DO-35	80009	152-0141-02
A3CR544	152-0141-02			DIO,SIG:ULTRA FAST;40V,150MA,4NS,2PF;1N4152,DO-35	80009	152-0141-02
A3CR566	152-0141-02			DIO,SIG:ULTRA FAST;40V,150MA,4NS,2PF;1N4152,DO-35	80009	152-0141-02
A3CR582	152-0307-00			DIO,SIG:ULTRA FAST;100V,4.0NS,1.5PF,DUAL COM-CATH;MSD6100,TO-92	04713	SSD1150
A3CR588	152-0141-02			DIO,SIG:ULTRA FAST;40V,150MA,4NS,2PF;1N4152,DO-35	80009	152-0141-02
A3CR589	152-0141-02			DIO,SIG:ULTRA FAST;40V,150MA,4NS,2PF;1N4152,DO-35	80009	152-0141-02
A3CR636	152-0141-02			DIO,SIG:ULTRA FAST;40V,150MA,4NS,2PF;1N4152,DO-35	80009	152-0141-02
A3CR647	152-0141-02			DIO,SIG:ULTRA FAST;40V,150MA,4NS,2PF;1N4152,DO-35	80009	152-0141-02
A3CR648	152-0141-02			DIO,SIG:ULTRA FAST;40V,150MA,4NS,2PF;1N4152,DO-35	80009	152-0141-02
A3CR662	152-0141-02			DIO,SIG:ULTRA FAST;40V,150MA,4NS,2PF;1N4152,DO-35	80009	152-0141-02
A3CR664	152-0141-02			DIO,SIG:ULTRA FAST;40V,150MA,4NS,2PF;1N4152,DO-35	80009	152-0141-02

1730-Series Replaceable Electrical Parts

Component Number	Tektronix Part Number	Serial / Assembly Number		Name & Description	Mfr. Code	Mfr. Part Number
		Effective	Discontinued			
A3CR665	152-0141-02			DIO,SIG:ULTRA FAST;40V,150MA,4NS,2PF;1N4152,DO-35	80009	152-0141-02
A3CR670	152-0141-02			DIO,SIG:ULTRA FAST;40V,150MA,4NS,2PF;1N4152,DO-35	80009	152-0141-02
A3CR671	152-0141-02			DIO,SIG:ULTRA FAST;40V,150MA,4NS,2PF;1N4152,DO-35	80009	152-0141-02
A3CR682	152-0141-02			DIO,SIG:ULTRA FAST;40V,150MA,4NS,2PF;1N4152,DO-35	80009	152-0141-02
A3CR696	152-0141-02			DIO,SIG:ULTRA FAST;40V,150MA,4NS,2PF;1N4152,DO-35	80009	152-0141-02
A3CR697	152-0141-02			DIO,SIG:ULTRA FAST;40V,150MA,4NS,2PF;1N4152,DO-35	80009	152-0141-02
A3CR698	152-0141-02			DIO,SIG:ULTRA FAST;40V,150MA,4NS,2PF;1N4152,DO-35	80009	152-0141-02
A3CR699	152-0141-02			DIO,SIG:ULTRA FAST;40V,150MA,4NS,2PF;1N4152,DO-35	80009	152-0141-02
A3CR746	152-0141-02			DIO,SIG:ULTRA FAST;40V,150MA,4NS,2PF;1N4152,DO-35	80009	152-0141-02
A3CR757	152-0141-02			DIO,SIG:ULTRA FAST;40V,150MA,4NS,2PF;1N4152,DO-35	80009	152-0141-02
A3CR758	152-0141-02			DIO,SIG:ULTRA FAST;40V,150MA,4NS,2PF;1N4152,DO-35	80009	152-0141-02
A3CR759	152-0141-02			DIO,SIG:ULTRA FAST;40V,150MA,4NS,2PF;1N4152,DO-35	80009	152-0141-02
A3CR760	152-0141-02			DIO,SIG:ULTRA FAST;40V,150MA,4NS,2PF;1N4152,DO-35	80009	152-0141-02
A3CR761	152-0141-02			DIO,SIG:ULTRA FAST;40V,150MA,4NS,2PF;1N4152,DO-35	80009	152-0141-02
A3CR762	152-0141-02			DIO,SIG:ULTRA FAST;40V,150MA,4NS,2PF;1N4152,DO-35	80009	152-0141-02
A3CR763	152-0141-02			DIO,SIG:ULTRA FAST;40V,150MA,4NS,2PF;1N4152,DO-35	80009	152-0141-02
A3CR778	152-0141-02			DIO,SIG:ULTRA FAST;40V,150MA,4NS,2PF;1N4152,DO-35	80009	152-0141-02
A3CR779	152-0141-02			DIO,SIG:ULTRA FAST;40V,150MA,4NS,2PF;1N4152,DO-35	80009	152-0141-02
A3CR825	152-0400-00			DIO,RECT:FAST RCVR;400V,1A,200NS;1N4936,DO-41,T&R	80009	152-0400-00
A3CR826	152-0141-02			DIO,SIG:ULTRA FAST;40V,150MA,4NS,2PF;1N4152,DO-35	80009	152-0141-02
A3CR840	152-0141-02			DIO,SIG:ULTRA FAST;40V,150MA,4NS,2PF;1N4152,DO-35	80009	152-0141-02
A3CR850	152-0141-02			DIO,SIG:ULTRA FAST;40V,150MA,4NS,2PF;1N4152,DO-35	80009	152-0141-02
A3CR865	152-0141-02			DIO,SIG:ULTRA FAST;40V,150MA,4NS,2PF;1N4152,DO-35	80009	152-0141-02
A3CR887	152-0141-02			DIO,SIG:ULTRA FAST;40V,150MA,4NS,2PF;1N4152,DO-35	80009	152-0141-02
A3CR924	152-0141-02			DIO,SIG:ULTRA FAST;40V,150MA,4NS,2PF;1N4152,DO-35	80009	152-0141-02
A3CR955	152-0141-02			DIO,SIG:ULTRA FAST;40V,150MA,4NS,2PF;1N4152,DO-35	80009	152-0141-02
A3CR988	152-0141-02			DIO,SIG:ULTRA FAST;40V,150MA,4NS,2PF;1N4152,DO-35	80009	152-0141-02
A3CR989	152-0141-02			DIO,SIG:ULTRA FAST;40V,150MA,4NS,2PF;1N4152,DO-35	80009	152-0141-02
A3CR990	152-0141-02			DIO,SIG:ULTRA FAST;40V,150MA,4NS,2PF;1N4152,DO-35	80009	152-0141-02
A3CR991	152-0141-02			DIODE,SIG:ULTRA FAST,40V,150MA,4NS,2PF,1N4152,DO-35	01295	1N4152R
A3J6	196-3146-00			CA ASSY,SP:FLT FLEX;FLX,27 AWG,1.0 L,PCB,TERM,STR BOTH ENDS	15912	FSN-LA
A3J9	196-3146-00			CA ASSY,SP:FLT FLEX;FLX,27 AWG,1.0 L,PCB,TERM,STR BOTH ENDS	15912	FSN-LA
A3J19	196-3146-00			CA ASSY,SP:FLT FLEX;FLX,27 AWG,1.0 L,PCB,TERM,STR BOTH ENDS	15912	FSN-LA
A3J49	196-3146-00			CA ASSY,SP:FLT FLEX;FLX,27 AWG,1.0 L,PCB,TERM,STR BOTH ENDS	15912	FSN-LA
A3J97	131-4752-00			CONN,HDR:PCB;MALE,45 DEG,1 X 2,0.1 CTR,0.240 MLG X 0.110 TAIL,30 GLD	80009	131-4752-00
A3J98	131-4794-00			CONN,HDR:PCB;MALE,STR,1 X 2,0.1 CTR,0.235 MLG X 0.112 TAIL,30 GLD,0.035 DIA PCB	80009	131-4794-00
A3J99	131-4530-00			CONN,HDR:	80009	131-4530-00
A3J107	131-3571-00			CONN,HDR:	80009	131-3571-00
A3J154	175-9797-00			CA ASSY,SP:FLT FLEX;FLX,10,27 AWG,2.5 L,1X10,BOX X STR,SLDR TAB,CONN NON PLZ	00779	487729-1
A3J155	174-1195-00			CA ASSY,SP,ELEC:10 CON,8.0 L,FLT FLEX	80009	174-1195-00
A3J197	131-4530-00			CONN,HDR:	80009	131-4530-00
A3J225	131-4752-00			CONN,HDR:PCB;MALE,45 DEG,1 X 2,0.1 CTR,0.240 MLG X 0.110 TAIL,30 GLD	80009	131-4752-00
A3J456	131-4530-00			CONN,HDR:	80009	131-4530-00
A3J504	131-4187-00			CONN,HDR:PCB;MALE,1 X 3,0.1 CTR,0.240 MLG X 0.110 TAIL,45 DEG	58050	082-0343-AS10
A3J540	131-4530-00			CONN,HDR:	80009	131-4530-00
A3J635	131-4187-00			CONN,HDR:PCB;MALE,1 X 3,0.1 CTR,0.240 MLG X 0.110 TAIL,45 DEG	58050	082-0343-AS10
A3J699	131-4530-00			CONN,HDR:	80009	131-4530-00
A3J932	131-3528-00			CONN,HDR:	15912	609-2407

1730-Series Replaceable Electrical Parts

Component Number	Tektronix Part Number	Serial / Assembly Number		Name & Description	Mfr. Code	Mfr. Part Number
		Effective	Discontinued			
A3L157	108-1262-00			COIL,RF:FXD,100UH,10%,Q=30,SRF 8.2MHZ,DCR 0.23 OHM,I MAX 0.75A RDL LEAD	80009	108-1262-00
A3L180	114-0500-00			COIL,RF,VAR:	80009	114-0500-00
A3L190	114-0500-00			COIL,RF,VAR:	80009	114-0500-00
A3L548	108-1268-00			COIL,RF:FXD,56UH,10%,ON PWDR	24226	10M562K
A3L643	108-1268-00			COIL,RF:FXD,56UH,10%,ON PWDR	24226	10M562K
A3L777	108-1351-00			COIL,RF:	80009	108-1351-00
A3L778	108-1268-00			COIL,RF:FXD,56UH,10%,ON PWDR	24226	10M562K
A3L779	108-0317-01			COIL,RF:IDCTR,15UH	80009	108-0317-01
A3L781	108-1352-00			COIL,RF:	80009	108-1352-00
A3L782	108-1351-00			COIL,RF:	80009	108-1351-00
A3P99	131-3199-00			CONN,SHUNT:FEMALE,STR,1 X 2,0.1 CTR,0.2 H,LOW PF, JUMPER	80009	131-3199-00
A3P197	131-3199-00			CONN,SHUNT:FEMALE,STR,1 X 2,0.1 CTR,0.2 H,LOW PF, JUMPER	80009	131-3199-00
A3P456	131-3199-00			CONN,SHUNT:FEMALE,STR,1 X 2,0.1 CTR,0.2 H,LOW PF, JUMPER	80009	131-3199-00
A3P504	131-3199-00			CONN,SHUNT:FEMALE,STR,1 X 2,0.1 CTR,0.2 H,LOW PF, JUMPER	80009	131-3199-00
A3P540	131-3199-00			CONN,SHUNT:FEMALE,STR,1 X 2,0.1 CTR,0.2 H,LOW PF, JUMPER	80009	131-3199-00
A3P635	131-3199-00			CONN,SHUNT:FEMALE,STR,1 X 2,0.1 CTR,0.2 H,LOW PF, JUMPER	80009	131-3199-00
A3P699	131-3199-00			CONN,SHUNT:FEMALE,STR,1 X 2,0.1 CTR,0.2 H,LOW PF, JUMPER	80009	131-3199-00
A3Q99	151-0188-00			XSTR,SIG:BIPOLAR,PNP:40V,200MA,250MHZ, AMPL:2N3906,TO-92 EBC	80009	151-0188-00
A3Q142	151-0188-00			XSTR,SIG:BIPOLAR,PNP:40V,200MA,250MHZ, AMPL:2N3906,TO-92 EBC	80009	151-0188-00
A3Q143	151-0190-00			XSTR,SIG:BIPOLAR,NPN:40V,200MA,300MHZ, AMPL:2N3904,TO-92 EBC	80009	151-0190-00
A3Q158	151-0710-00			XSTR,SIG:BIPOLAR,NPN:40V,1.0A,50MHZ, AMPL:2N6715/MPSW01A,TO-237/TO-226AE	80009	151-0710-00
A3Q178	151-0190-00			XSTR,SIG:BIPOLAR,NPN:40V,200MA,300MHZ, AMPL:2N3904,TO-92 EBC	80009	151-0190-00
A3Q242	151-0188-00			XSTR,SIG:BIPOLAR,PNP:40V,200MA,250MHZ, AMPL:2N3906,TO-92 EBC	80009	151-0188-00
A3Q243	151-0188-00			XSTR,SIG:BIPOLAR,PNP:40V,200MA,250MHZ, AMPL:2N3906,TO-92 EBC	80009	151-0188-00
A3Q272	151-0190-00			XSTR,SIG:BIPOLAR,NPN:40V,200MA,300MHZ, AMPL:2N3904,TO-92 EBC	80009	151-0190-00
A3Q280	151-0211-00			XSTR,SIG:BIPOLAR,NPN:30V VCEO,55V VCBO,400MA,500MHZ, AMPL:2N3866,TO-39	80009	151-0211-00
				ATTACHED PARTS		
	214-1291-00			HTSK,XSTR:TO-5,SIL BRZ PTD BLK	05820	207SB
	342-0324-00			INSULATOR,DISK:XSTR,NYL	80009	342-0324-00
				END ATTACHED PARTS		
A3Q289	151-0211-00			XSTR,SIG:BIPOLAR,NPN:30V VCEO,55V VCBO,400MA,500MHZ, AMPL:2N3866,TO-39	80009	151-0211-00
				ATTACHED PARTS		
	214-1291-00			HTSK,XSTR:TO-5,SIL BRZ PTD BLK	05820	207SB
	342-0324-00			INSULATOR,DISK:XSTR,NYL	80009	342-0324-00
				END ATTACHED PARTS		
A3Q298	151-0190-00			XSTR,SIG:BIPOLAR,NPN:40V,200MA,300MHZ, AMPL:2N3904,TO-92 EBC	80009	151-0190-00
A3Q299	151-0190-00			XSTR,SIG:BIPOLAR,NPN:40V,200MA,300MHZ, AMPL:2N3904,TO-92 EBC	80009	151-0190-00
A3Q346	151-0190-00			XSTR,SIG:BIPOLAR,NPN:40V,200MA,300MHZ, AMPL:2N3904,TO-92 EBC	80009	151-0190-00

1730-Series Replaceable Electrical Parts

Component Number	Tektronix Part Number	Serial / Assembly Number		Name & Description	Mfr. Code	Mfr. Part Number
		Effective	Discontinued			
A3Q347	151-0190-00			XSTR,SIG:BIPOLAR,NPN;40V,200MA,300MHZ,AMPL:2N3904,TO-92 EBC	80009	151-0190-00
A3Q383	151-0198-00			XSTR,SIG:BIPOLAR,NPN;15V,50MA,600 MHZ,AMPL:MPS918,TO-92 EBC	80009	151-0198-00
A3Q385	151-0198-00			XSTR,SIG:BIPOLAR,NPN;15V,50MA,600 MHZ,AMPL:MPS918,TO-92 EBC	80009	151-0198-00
A3Q450	151-0190-00			XSTR,SIG:BIPOLAR,NPN;40V,200MA,300MHZ,AMPL:2N3904,TO-92 EBC	80009	151-0190-00
A3Q451	151-0190-00			XSTR,SIG:BIPOLAR,NPN;40V,200MA,300MHZ,AMPL:2N3904,TO-92 EBC	80009	151-0190-00
A3Q457	151-0207-01			XSTR,SIG:BIPOLAR,NPN;45V,300MA,250MHZ,AMPL:PN100A,TO-92 EBC,T&A	80009	151-0207-01
A3Q458	151-0207-01			XSTR,SIG:BIPOLAR,NPN;45V,300MA,250MHZ,AMPL:PN100A,TO-92 EBC,T&A	80009	151-0207-01
A3Q459	151-0190-00			XSTR,SIG:BIPOLAR,NPN;40V,200MA,300MHZ,AMPL:2N3904,TO-92 EBC	80009	151-0190-00
A3Q469	151-0198-00			XSTR,SIG:BIPOLAR,NPN;15V,50MA,600 MHZ,AMPL:MPS918,TO-92 EBC	80009	151-0198-00
A3Q477	151-0198-00			XSTR,SIG:BIPOLAR,NPN;15V,50MA,600 MHZ,AMPL:MPS918,TO-92 EBC	80009	151-0198-00
A3Q478	151-0198-00			XSTR,SIG:BIPOLAR,NPN;15V,50MA,600 MHZ,AMPL:MPS918,TO-92 EBC	80009	151-0198-00
A3Q497	151-0188-00			XSTR,SIG:BIPOLAR,PNP;40V,200MA,250MHZ,AMPL:2N3906,TO-92 EBC	80009	151-0188-00
A3Q498	151-0190-00			XSTR,SIG:BIPOLAR,NPN;40V,200MA,300MHZ,AMPL:2N3904,TO-92 EBC	80009	151-0190-00
A3Q499	151-0190-00			XSTR,SIG:BIPOLAR,NPN;40V,200MA,300MHZ,AMPL:2N3904,TO-92 EBC	80009	151-0190-00
A3Q540	151-0190-00			XSTR,SIG:BIPOLAR,NPN;40V,200MA,300MHZ,AMPL:2N3904,TO-92 EBC	80009	151-0190-00
A3Q541	151-0190-00			XSTR,SIG:BIPOLAR,NPN;40V,200MA,300MHZ,AMPL:2N3904,TO-92 EBC	80009	151-0190-00
A3Q542	151-0190-00			XSTR,SIG:BIPOLAR,NPN;40V,200MA,300MHZ,AMPL:2N3904,TO-92 EBC	80009	151-0190-00
A3Q558	151-0207-01			XSTR,SIG:BIPOLAR,NPN;45V,300MA,250MHZ,AMPL:PN100A,TO-92 EBC,T&A	80009	151-0207-01
A3Q566	151-0216-04			XSTR,SIG:BIPOLAR,PNP;25V,100MA,170MHZ,AMPL:MPS6523,TO-92 EBC,T&A	80009	151-0216-04
A3Q587	151-0188-00			XSTR,SIG:BIPOLAR,PNP;40V,200MA,250MHZ,AMPL:2N3906,TO-92 EBC	80009	151-0188-00
A3Q590	151-0190-00			XSTR,SIG:BIPOLAR,NPN;40V,200MA,300MHZ,AMPL:2N3904,TO-92 EBC	80009	151-0190-00
A3Q626	151-0190-00			XSTR,SIG:BIPOLAR,NPN;40V,200MA,300MHZ,AMPL:2N3904,TO-92 EBC	80009	151-0190-00
A3Q669	151-0198-00			XSTR,SIG:BIPOLAR,NPN;15V,50MA,600 MHZ,AMPL:MPS918,TO-92 EBC	80009	151-0198-00
A3Q673	151-0221-08			XSTR,SIG:BIPOLAR,PNP;12V,80MA,SWG; MPS4258,TO-92 EBC,T&A	80009	151-0221-08
A3Q674	151-0221-08			XSTR,SIG:BIPOLAR,PNP;12V,80MA,SWG; MPS4258,TO-92 EBC,T&A	80009	151-0221-08
A3Q684	151-0188-00			XSTR,SIG:BIPOLAR,PNP;40V,200MA,250MHZ,AMPL:2N3906,TO-92 EBC	80009	151-0188-00
A3Q737	151-0188-00			XSTR,SIG:BIPOLAR,PNP;40V,200MA,250MHZ,AMPL:2N3906,TO-92 EBC	80009	151-0188-00
A3Q750	151-0188-00			XSTR,SIG:BIPOLAR,PNP;40V,200MA,250MHZ,AMPL:2N3906,TO-92 EBC	80009	151-0188-00
A3Q762	151-0190-00			XSTR,SIG:BIPOLAR,NPN;40V,200MA,300MHZ,AMPL:2N3904,TO-92 EBC	80009	151-0190-00
A3Q763	151-0190-00			XSTR,SIG:BIPOLAR,NPN;40V,200MA,300MHZ,AMPL:2N3904,TO-92 EBC	80009	151-0190-00

1730-Series Replaceable Electrical Parts

Component Number	Tektronix Part Number	Serial / Assembly Number		Name & Description	Mfr. Code	Mfr. Part Number
		Effective	Discontinued			
A3Q764	151-0190-00			XSTR,SIG:BIPOLAR,NPN:40V,200MA,300MHZ,AMPL:2N3904,TO-92 EBC	80009	151-0190-00
A3Q765	151-0190-00			XSTR,SIG:BIPOLAR,NPN:40V,200MA,300MHZ,AMPL:2N3904,TO-92 EBC	80009	151-0190-00
A3Q774	151-0188-00			XSTR,SIG:BIPOLAR,PNP:40V,200MA,250MHZ,AMPL:2N3906,TO-92 EBC	80009	151-0188-00
A3Q775	151-0195-02			XSTR,SIG:BIPOLAR,NPN:20V,100MA,150MHZ,AMPLIFIER;2 N5223/MPS6521,TO-92 EBC,T&A	80009	151-0195-02
A3Q788	151-0188-00			XSTR,SIG:BIPOLAR,PNP:40V,200MA,250MHZ,AMPL:2N3906,TO-92 EBC	80009	151-0188-00
A3Q790	151-0188-00			XSTR,SIG:BIPOLAR,PNP:40V,200MA,250MHZ,AMPL:2N3906,TO-92 EBC	80009	151-0188-00
A3Q791	151-0188-00			XSTR,SIG:BIPOLAR,PNP:40V,200MA,250MHZ,AMPL:2N3906,TO-92 EBC	80009	151-0188-00
A3Q792	151-0188-00			XSTR,SIG:BIPOLAR,PNP:40V,200MA,250MHZ,AMPL:2N3906,TO-92 EBC	80009	151-0188-00
A3Q793	151-0188-00			XSTR,SIG:BIPOLAR,PNP:40V,200MA,250MHZ,AMPL:2N3906,TO-92 EBC	80009	151-0188-00
A3Q798	151-0188-00			XSTR,SIG:BIPOLAR,PNP:40V,200MA,250MHZ,AMPL:2N3906,TO-92 EBC	80009	151-0188-00
A3Q799	151-0188-00			XSTR,SIG:BIPOLAR,PNP:40V,200MA,250MHZ,AMPL:2N3906,TO-92 EBC	80009	151-0188-00
A3Q805	151-0195-02			XSTR,SIG:BIPOLAR,NPN:20V,100MA,150MHZ,AMPLIFIER;2 N5223/MPS6521,TO-92 EBC,T&A	80009	151-0195-02
A3Q806	151-0216-04			XSTR,SIG:BIPOLAR,PNP:25V,100MA,170MHZ,AMPL:MPS6523,TO-92 EBC,T&A	80009	151-0216-04
A3Q821	151-0188-00			XSTR,SIG:BIPOLAR,PNP:40V,200MA,250MHZ,AMPL:2N3906,TO-92 EBC	80009	151-0188-00
A3Q855	151-0188-00			XSTR,SIG:BIPOLAR,PNP:40V,200MA,250MHZ,AMPL:2N3906,TO-92 EBC	80009	151-0188-00
A3Q856	151-0195-02			XSTR,SIG:BIPOLAR,NPN:20V,100MA,150MHZ,AMPLIFIER;2 N5223/MPS6521,TO-92 EBC,T&A	80009	151-0195-02
A3Q858	151-0216-04			XSTR,SIG:BIPOLAR,PNP:25V,100MA,170MHZ,AMPL:MPS6523,TO-92 EBC,T&A	80009	151-0216-04
A3Q860	151-0216-04			XSTR,SIG:BIPOLAR,PNP:25V,100MA,170MHZ,AMPL:MPS6523,TO-92 EBC,T&A	80009	151-0216-04
A3Q862	151-0347-00			XSTR,SIG:BIPOLAR,NPN:160V,600MA,100MHZ,AMPL:2N5551,TO-92 EBC	80009	151-0347-00
A3Q864	151-0347-00			XSTR,SIG:BIPOLAR,NPN:160V,600MA,100MHZ,AMPL:2N5551,TO-92 EBC	80009	151-0347-00
A3Q865	151-0350-00			XSTR,SIG:BIPOLAR,PNP:150V,600MA,100MHZ,AMPL:2N5401,TO-92 EBC	04713	2N5401
A3Q868	151-0350-00			XSTR,SIG:BIPOLAR,PNP:150V,600MA,100MHZ,AMPL:2N5401,TO-92 EBC	04713	2N5401
A3Q877	151-0188-00			XSTR,SIG:BIPOLAR,PNP:40V,200MA,250MHZ,AMPL:2N3906,TO-92 EBC	80009	151-0188-00
A3Q973	151-0188-00			XSTR,SIG:BIPOLAR,PNP:40V,200MA,250MHZ,AMPL:2N3906,TO-92 EBC	80009	151-0188-00
A3Q992	151-0188-00			XSTR,SIG:BIPOLAR,PNP:40V,200MA,250MHZ,AMPL:2N3906,TO-92 EBC	80009	151-0188-00
A3R22	322-3329-00			RES,FXD,FILM:26.1K OHM,1%,0.2W,TC=TOMI,SMALL BODY	57668	CRB20 FXE 26K1
A3R81	322-3481-00			RES,FXD,FILM:1M OHM,1%,0.2W,TC=TO	80009	322-3481-00
A3R82	322-3285-00			RES,FXD,FILM:9.09K OHM,1%,0.2W,TC=TO	80009	322-3285-00
A3R83	322-3262-00			RES,FXD,FILM:5.23K OHM,1%,0.2W,TC=TO	80009	322-3262-00
A3R84	322-3105-00			RES,FXD:MET FILM;121 OHM,1%,0.2W,TC=100 PPM;AXIAL	80009	322-3105-00
A3R85	322-3414-00			RES,FXD:MET FILM;200K OHM,1%,0.2W,TC=100 PPM;AXIAL	91637	CCF501G20002F
A3R86	322-3105-00			RES,FXD:MET FILM;121 OHM,1%,0.2W,TC=100 PPM;AXIAL	80009	322-3105-00
A3R87	322-3268-00			RES,FXD,FILM:6.04K OHM,1%,0.2W,TC=TO	80009	322-3268-00
A3R88	322-3239-00			RES,FXD,FILM:3.01K OHM,1%,0.2W,TC=TO	57668	CRB20 FXE 3K01
A3R89	322-3231-00			RES,FXD,FILM:2.49K OHM,1%,0.2W,TC=TO	80009	322-3231-00

1730-Series Replaceable Electrical Parts

Component Number	Tektronix Part Number	Serial / Assembly Number		Name & Description	Mfr. Code	Mfr. Part Number
		Effective	Discontinued			
A3R90	322-3273-00			RES,FXD:MET FILM;6.81K OHM,1%,0.2W,TC=100 PPM	80009	322-3273-00
A3R91	322-3302-00			RES,FXD,FILM:13.7K OHM,1%,0.2W,TC=T0	80009	322-3302-00
A3R92	322-3218-00			RES,FXD:MET FILM;1.82K OHM,1%,0.2W,TC=100 PPM	80009	322-3218-00
A3R93	322-3339-00			RES,FXD:MET FILM;33.2K OHM,1%,0.2W,TC=100 PPM	80009	322-3339-00
A3R94	322-3193-00			RES,FXD:MET FILM;1K OHM,1%,0.2W,TC=100 PPM;AXIAL	57668	CRB20 FXE 1K00
A3R95	322-3258-00			RES,FXD:MET FILM;4.75K OHM,1%,0.2W,TC=100 PPM	80009	322-3258-00
A3R96	322-3097-00			RES,FXD:MET FILM;100 OHM,1%,0.2W,TC=100 PPM;AXIAL	57668	CRB20 FXE 100E
A3R97	322-3297-00			RES,FXD:MET FILM;12.1K OHM,1%,0.2W,TC=100 PPM	57668	CRB20 FXE 12K1
A3R98	322-3294-00			RES,FXD,FILM:11.3K OHM,1%,0.2W,TC=T0	80009	322-3294-00
A3R99	322-3175-00			RES,FXD,FILM:649 OHM,1%,0.2W,TC=T0	80009	322-3175-00
A3R136	322-3097-00			RES,FXD:MET FILM;100 OHM,1%,0.2W,TC=100 PPM;AXIAL	57668	CRB20 FXE 100E
A3R137	322-3097-00			RES,FXD:MET FILM;100 OHM,1%,0.2W,TC=100 PPM;AXIAL	57668	CRB20 FXE 100E
A3R138	322-3369-00			RES,FXD:MET FILM;68.1K OHM,1%,0.2W,TC=100 PPM	80009	322-3369-00
A3R139	322-3289-00			RES,FXD:MET FILM;10K OHM,1%,0.2W,TC=100 PPM;AXIAL	80009	322-3289-00
A3R143	301-0101-00			RES,FXD,FILM:100 OHM,5%,0.5W MI	19701	5053CX100RDJ
A3R149	322-3330-00			RES,FXD,FILM:26.7K OHM,1%,0.2W,TC=T0	80009	322-3330-00
A3R161	322-3289-00			RES,FXD:MET FILM;10K OHM,1%,0.2W,TC=100 PPM;AXIAL	80009	322-3289-00
A3R162	322-3385-00			RES,FXD:MET FILM;100K OHM,1%,0.2W,TC=100 PPM;AXIAL	57668	CRB20 FXE 100K
A3R163	322-3385-00			RES,FXD:MET FILM;100K OHM,1%,0.2W,TC=100 PPM;AXIAL	57668	CRB20 FXE 100K
A3R164	322-3322-00			RES,FXD:MET FILM;22.1K OHM,1%,0.2W,TC=100 PPM	80009	322-3322-00
A3R166	322-3354-00			RES,FXD:MET FILM;47.5K OHM,1%,0.2W,TC=100 PPM	80009	322-3354-00
A3R167	311-2230-00			RES,VAR,TRMR:CERMET;500 OHM,20%,0.5W,0.197 SQ,TOP ADJUST;T&R	TK1450	GF06UT 500
A3R168	311-2230-00			RES,VAR,TRMR:CERMET;500 OHM,20%,0.5W,0.197 SQ,TOP ADJUST;T&R	TK1450	GF06UT 500
A3R175	322-3258-00			RES,FXD:MET FILM;4.75K OHM,1%,0.2W,TC=100 PPM	80009	322-3258-00
A3R176	322-3277-00			RES,FXD,FILM:7.5K OHM,1%,0.2W,TC=T0	57668	CRB20 FXE 7K50
A3R177	322-3277-00			RES,FXD,FILM:7.5K OHM,1%,0.2W,TC=T0	57668	CRB20 FXE 7K50
A3R180	322-3034-00			RES,FXD:MET FILM;22.1 OHM,1%,0.2W,TC=100 PPM;AXIAL	57668	CRB20FXE2K94
A3R183	301-0472-00			RES,FXD,FILM:4.7K OHM,5%,0.5W	80009	301-0472-00
A3R184	308-0783-00			RES,FXD,WW:1K OHM,1%,3W,TC=30PPM	80009	308-0783-00
A3R186	308-0783-00			RES,FXD,WW:1K OHM,1%,3W,TC=30PPM	80009	308-0783-00
A3R187	301-0472-00			RES,FXD,FILM:4.7K OHM,5%,0.5W	80009	301-0472-00
A3R189	322-3034-00			RES,FXD:MET FILM;22.1 OHM,1%,0.2W,TC=100 PPM;AXIAL	57668	CRB20FXE2K94
A3R192	322-3066-00			RES,FXD:MET FILM;47.5 OHM,1%,0.2W,TC=100 PPM;AXIAL	09969	CCF502G47R50F
A3R196	321-0603-07			RES,FXD,FILM:15K OHM,0.1%,0.125W,TC=T9	80009	321-0603-07
A3R197	322-3410-00			RES,FXD:MET FILM;182K OHM,1%,0.2W,TC=100 PPM;AXIAL	80009	322-3410-00
A3R198	321-0603-07			RES,FXD,FILM:15K OHM,0.1%,0.125W,TC=T9	80009	321-0603-07
A3R199	315-0821-00			RES,FXD,FILM:820 OHM,5%,0.25W	80009	315-0821-00
A3R206	322-3001-00			RES,FXD:MET FILM;10 OHM,1%,0.2W,TC=100 PPM;AXIAL	80009	322-3001-00
A3R207	322-3001-00			RES,FXD:MET FILM;10 OHM,1%,0.2W,TC=100 PPM;AXIAL	80009	322-3001-00
A3R209	311-2236-00			RES,VAR,TRMR:CERMET;20K OHM,20%,0.5W,0.197 SQ	TK1450	GF06UT 20K
A3R221	322-3289-00			RES,FXD:MET FILM;10K OHM,1%,0.2W,TC=100 PPM;AXIAL	80009	322-3289-00
A3R225	322-3300-00			RES,FXD,FILM:13K OHM,1%,0.2W,TC=T0	80009	322-3300-00
A3R226	322-3204-00			RES,FXD,FILM:1.3K OHM,1%,0.2W,TC=T0	80009	322-3204-00
A3R227	322-3258-00			RES,FXD:MET FILM;4.75K OHM,1%,0.2W,TC=100 PPM	80009	322-3258-00
A3R233	322-3250-00			RES,FXD:MET FILM;3.92K OHM,1%,0.2W,TC=100 PPM	91637	CCF50-2F39200F
A3R236	322-3322-00			RES,FXD:MET FILM;22.1K OHM,1%,0.2W,TC=100 PPM	80009	322-3322-00
A3R237	322-3289-00			RES,FXD:MET FILM;10K OHM,1%,0.2W,TC=100 PPM;AXIAL	80009	322-3289-00
A3R238	322-3377-00			RES,FXD:MET FILM;82.5K OHM,1%,0.2W,TC=100 PPM	91637	CCF50-2F82501F
A3R240	322-3354-00			RES,FXD:MET FILM;47.5K OHM,1%,0.2W,TC=100 PPM	80009	322-3354-00
A3R241	322-3377-00			RES,FXD:MET FILM;82.5K OHM,1%,0.2W,TC=100 PPM	91637	CCF50-2F82501F
A3R242	322-3193-00			RES,FXD:MET FILM;1K OHM,1%,0.2W,TC=100 PPM;AXIALY	57668	CRB20 FXE 1K00
A3R243	322-3318-00			RES,FXD:MET FILM;20K OHM,1%,0.2W,TC=100 PPM;AXIAL	57668	CRB20 FXE 20K0
A3R244	322-3289-00			RES,FXD:MET FILM;10K OHM,1%,0.2W,TC=100 PPM;AXIAL	80009	322-3289-00
A3R245	311-2238-00			RES,VAR,TRMR:CERMET;50K OHM,20%,0.5W,0.197 SQ	TK1450	GF06UT 50 K
A3R246	322-3066-00			RES,FXD:MET FILM;47.5 OHM,1%,0.2W,TC=100 PPM;AXIAL	09969	CCF502G47R50F
A3R247	322-3354-00			RES,FXD:MET FILM;47.5K OHM,1%,0.2W,TC=100 PPM	80009	322-3354-00

1730-Series Replaceable Electrical Parts

Component Number	Tektronix Part Number	Serial / Assembly Number		Name & Description	Mfr. Code	Mfr. Part Number
		Effective	Discontinued			
A3R248	322-3226-00			RES,FXD:MET FILM;2.21K OHM,1%,0.2W,TC=100 PPM	57668	CRB20 FXE 2K21
A3R249	322-3193-00			RES,FXD:MET FILM;1K OHM,1%,0.2W,TC=100 PPM;AXIAL	57668	CRB20 FXE 1K00
A3R254	322-3254-00			RES,FXD,FILM:4.32K OHM,1%,0.2W,TC=T0	80009	322-3254-00
A3R255	322-3193-00			RES,FXD:MET FILM;1K OHM,1%,0.2W,TC=100 PPM;AXIAL	57668	CRB20 FXE 1K00
A3R257	307-0023-00			RES,FXD,CMPSN:4.7 OHM,10%,0.5W	80009	307-0023-00
A3R258	322-3289-00			RES,FXD:MET FILM;10K OHM,1%,0.2W,TC=100 PPM;AXIAL	80009	322-3289-00
A3R263	322-3193-00			RES,FXD:MET FILM;1K OHM,1%,0.2W,TC=100 PPM;AXIAL	57668	CRB20 FXE 1K00
A3R264	321-0172-00			RES,FXD,FILM:604 OHM,1%,0.125W,TC=T0	80009	321-0172-00
A3R266	322-3258-00			RES,FXD:MET FILM;4.75K OHM,1%,0.2W,TC=100 PPM	80009	322-3258-00
A3R267	322-3258-00			RES,FXD:MET FILM;4.75K OHM,1%,0.2W,TC=100 PPM	80009	322-3258-00
A3R268	321-0172-00			RES,FXD,FILM:604 OHM,1%,0.125W,TC=T0	80009	321-0172-00
A3R272	322-3289-00			RES,FXD:MET FILM;10K OHM,1%,0.2W,TC=100 PPM;AXIAL	80009	322-3289-00
A3R273	322-3363-00			RES,FXD,FILM:59K OHM,1%,0.2W,TC=T0	80009	322-3363-00
A3R274	311-2240-00			RES,VAR,NONWW:TRMR,200K OHM,20%,0.5W LIN	TK1450	GF06UT 200K
A3R276	322-3097-00			RES,FXD:MET FILM;100 OHM,1%,0.2W,TC=100 PPM;AXIAL	57668	CRB20 FXE 100E
A3R294	322-3210-00			RES,FXD:MET FILM;1.5K OHM,1%,0.2W,TC=100 PPM;AXIAL	57668	CRB20 FXE 1K50
A3R295	322-3034-00			RES,FXD:MET FILM;22.1 OHM,1%,0.2W,TC=100 PPM;AXIAL	57668	CRB20FXE2K94
A3R296	322-3097-00			RES,FXD:MET FILM;100 OHM,1%,0.2W,TC=100 PPM;AXIAL	57668	CRB20 FXE 100E
A3R297	322-3239-00			RES,FXD,FILM:3.01K OHM,1%,0.2W,TC=T0	57668	CRB20 FXE 3K01
A3R298	322-3243-00			RES,FXD:MET FILM;3.32K OHM,1%,0.2W,TC=100 PPM	91637	CCF50-1-G33200F
A3R299	322-3097-00			RES,FXD:MET FILM;100 OHM,1%,0.2W,TC=100 PPM;AXIAL	57668	CRB20 FXE 100E
A3R304	322-3001-00			RES,FXD:MET FILM;10 OHM,1%,0.2W,TC=100 PPM;AXIAL	80009	322-3001-00
A3R305	322-3001-00			RES,FXD:MET FILM;10 OHM,1%,0.2W,TC=100 PPM;AXIAL	80009	322-3001-00
A3R306	322-3001-00			RES,FXD:MET FILM;10 OHM,1%,0.2W,TC=100 PPM;AXIAL	80009	322-3001-00
A3R307	322-3001-00			RES,FXD:MET FILM;10 OHM,1%,0.2W,TC=100 PPM;AXIAL	80009	322-3001-00
A3R327	322-3330-00			RES,FXD,FILM:26.7K OHM,1%,0.2W,TC=T0	80009	322-3330-00
A3R331	322-3193-00			RES,FXD:MET FILM;1K OHM,1%,0.2W,TC=100 PPM;AXIAL	57668	CRB20 FXE 1K00
A3R343	322-3289-00			RES,FXD:MET FILM;10K OHM,1%,0.2W,TC=100 PPM;AXIAL	80009	322-3289-00
A3R344	322-3289-00			RES,FXD:MET FILM;10K OHM,1%,0.2W,TC=100 PPM;AXIAL	80009	322-3289-00
A3R356	322-3226-00			RES,FXD:MET FILM;2.21K OHM,1%,0.2W,TC=100 PPM	57668	CRB20 FXE 2K21
A3R358	322-3239-00			RES,FXD,FILM:3.01K OHM,1%,0.2W,TC=T0	57668	CRB20 FXE 3K01
A3R363	322-3289-00			RES,FXD:MET FILM;10K OHM,1%,0.2W,TC=100 PPM;AXIAL	80009	322-3289-00
A3R367	322-3203-00			RES,FXD,FILM:1.27K OHM,1%,0.2W,TC=T0	80009	322-3203-00
A3R368	322-3203-00			RES,FXD,FILM:1.27K OHM,1%,0.2W,TC=T0	80009	322-3203-00
A3R370	322-3097-00			RES,FXD:MET FILM;100 OHM,1%,0.2W,TC=100 PPM;AXIAL	57668	CRB20 FXE 100E
A3R371	322-3300-02			RES,FXD,FILM:13K OHM,0.5%,0.2W,TC=T2	57668	CRB20 DYE 13K0
A3R372	322-3185-00			RES,FXD:MET FILM;825 OHM,1%,0.2W,TC=100 PPM;AXIALY	57668	CRB20 FXE 825E
A3R373	322-3165-00			RES,FXD,FILM:511 OHM,1%,0.2W,TC=T0	57668	CRB20 FXE 511E
A3R374	321-0190-00			RES,FXD,FILM:931 OHM,1%,0.125W,TC=T0	80009	321-0190-00
A3R376	322-3114-00			RES,FXD:MET FILM;150 OHM,1%,0.2W,TC=100 PPM;AXIAL	91637	CCF50-2-G1500F
A3R377	322-3141-00			RES,FXD,FILM:287 OHM,1%,0.2W,TC=T0	57668	CRB20 FXE 287E
A3R378	322-3201-00			RES,FXD:MET FILM;1.21K OHM,1%,0.2W,TC=100 PPM	80009	322-3201-00
A3R379	322-3066-00			RES,FXD:MET FILM;47.5 OHM,1%,0.2W,TC=100 PPM;AXIAL	09969	CCF502G47R50F
A3R380	322-3256-00			RES,FXD,FILM:4.53K OHM,1%,0.2W,TC=T0	80009	322-3256-00
A3R381	322-3256-00			RES,FXD,FILM:4.53K OHM,1%,0.2W,TC=T0	80009	322-3256-00
A3R382	322-3155-00			RES,FXD,FILM:402 OHM,1%,0.2W,TC=T0	80009	322-3155-00
A3R383	322-3271-00			RES,FXD,FILM:6.49K OHM,1%,0.2W,TC=T0	91637	CCF502G64900FT
A3R384	322-3034-00			RES,FXD:MET FILM;22.1 OHM,1%,0.2W,TC=100 PPM;AXIAL	57668	CRB20FXE2K94
A3R385	322-3318-00			RES,FXD:MET FILM;20K OHM,1%,0.2W,TC=100 PPM;AXIAL	57668	CRB20 FXE 20K0
A3R386	322-3271-00			RES,FXD,FILM:6.49K OHM,1%,0.2W,TC=T0	91637	CCF502G64900FT
A3R387	322-3034-00			RES,FXD:MET FILM;22.1 OHM,1%,0.2W,TC=100 PPM;AXIAL	57668	CRB20FXE2K94
A3R388	322-3244-00			RES,FXD,FILM:3.4K OHM,1%,0.2W,TC=T0	80009	322-3244-00
A3R389	321-0274-00			RES,FXD,FILM:6.98K OHM,1%,0.125W,TC=T0	80009	321-0274-00
A3R390	322-3097-00			RES,FXD:MET FILM;100 OHM,1%,0.2W,TC=100 PPM;AXIAL	57668	CRB20 FXE 100E
A3R392	321-0754-07			RES,FXD,FILM:900 OHM,0.1%,0.125W,TC=T9	2M627	
A3R393	321-0754-07			RES,FXD,FILM:900 OHM,0.1%,0.125W,TC=T9	2M627	
A3R394	322-3147-00			RES,FXD:MET FILM;332 OHM,1%,0.2W,TC=100 PPM;AXIAL	80009	322-3147-00
A3R395	322-3289-00			RES,FXD:MET FILM;10K OHM,1%,0.2W,TC=100 PPM;AXIAL	80009	322-3289-00

1730-Series Replaceable Electrical Parts

Component Number	Tektronix Part Number	Serial / Assembly Number		Name & Description	Mfr. Code	Mfr. Part Number
		Effective	Discontinued			
A3R409	307-0106-00			RES,FXD,CMPSN:4.7 OHM,5%,0.25W	01121	CB47G5
A3R423	307-0446-00			RES NTWK,FXD,FI:10K OHM,20%,(9)RES	80009	307-0446-00
A3R435	322-3297-00			RES,FXD,MET FILM;12.1K OHM,1%,0.2W,TC=100 PPM	57668	CRB20 FXE 12K1
A3R440	322-3385-00			RES,FXD,MET FILM;100K OHM,1%,0.2W,TC=100 PPM;AXIAL	57668	CRB20 FXE 100K
A3R441	322-3258-00			RES,FXD,MET FILM;4.75K OHM,1%,0.2W,TC=100 PPM	80009	322-3258-00
A3R442	322-3258-00			RES,FXD,MET FILM;4.75K OHM,1%,0.2W,TC=100 PPM	80009	322-3258-00
A3R443	322-3356-00			RES,FXD,FILM:49.9K OHM,1%,0.2W,TC=T0	80009	322-3356-00
A3R444	322-3356-00			RES,FXD,FILM:49.9K OHM,1%,0.2W,TC=T0	80009	322-3356-00
A3R445	322-3429-00			RES,FXD,FILM:287K OHM,1%,0.2W,TC=T0	80009	322-3429-00
A3R446	321-0486-00			RES,FXD,FILM:1.13 MEG OHM,1%,0.125W,T=T0	80009	321-0486-00
A3R447	315-0225-00			RES,FXD,FILM:2.2M OHM,5%,0.25W	01121	CB2255
A3R454	322-3231-00			RES,FXD,FILM:2.49K OHM,1%,0.2W,TC=T0	80009	322-3231-00
A3R455	322-3231-00			RES,FXD,FILM:2.49K OHM,1%,0.2W,TC=T0	80009	322-3231-00
A3R456	321-0089-00			RES,FXD,FILM:82.5 OHM,1%,0.125W,TC=T0	80009	321-0089-00
A3R457	321-0121-00			RES,FXD,FILM:178 OHM,1%,0.125W,TC=T0	07716	CEAD178R0F
A3R458	322-3258-00			RES,FXD,MET FILM;4.75K OHM,1%,0.2W,TC=100 PPM	80009	322-3258-00
A3R459	322-3289-00			RES,FXD,MET FILM;10K OHM,1%,0.2W,TC=100 PPM;AXIAL	80009	322-3289-00
A3R462	322-3281-00			RES,FXD,MET FILM;8.25K OHM,1%,0.2W,TC=100 PPM	80009	322-3281-00
A3R463	322-3322-00			RES,FXD,MET FILM;22.1K OHM,1%,0.2W,TC=100 PPM	80009	322-3322-00
A3R464	322-3258-00			RES,FXD,MET FILM;4.75K OHM,1%,0.2W,TC=100 PPM	80009	322-3258-00
A3R465	322-3243-00			RES,FXD,MET FILM;3.32K OHM,1%,0.2W,TC=100 PPM	91637	CCF50-1-G33200F
A3R466	322-3258-00			RES,FXD,MET FILM;4.75K OHM,1%,0.2W,TC=100 PPM	80009	322-3258-00
A3R470	322-3114-00			RES,FXD,MET FILM;150 OHM,1%,0.2W,TC=100 PPM;AXIAL	91637	CCF50-2-G1500F
A3R471	322-3289-00			RES,FXD,MET FILM;10K OHM,1%,0.2W,TC=100 PPM;AXIAL	80009	322-3289-00
A3R472	322-3210-00			RES,FXD,MET FILM;1.5K OHM,1%,0.2W,TC=100 PPM;AXIAL	57668	CRB20 FXE 1K50
A3R473	322-3226-00			RES,FXD,MET FILM;2.21K OHM,1%,0.2W,TC=100 PPM	57668	CRB20 FXE 2K21
A3R474	322-3147-00			RES,FXD,MET FILM;332 OHM,1%,0.2W,TC=100 PPM;AXIAL	80009	322-3147-00
A3R475	322-3222-00			RES,FXD,MET FILM;2K OHM,1%,0.2W,TC=100 PPM;AXIAL	57668	CRB20 FXE 2K00
A3R477	322-3311-00			RES,FXD,FILM:16.9K OHM,1%,0.2W,TC=T0	56845	CCF-50-2-1692F
A3R478	322-3193-00			RES,FXD,MET FILM;1K OHM,1%,0.2W,TC=100 PPM;AXIAL	57668	CRB20 FXE 1K00
A3R479	322-3243-00			RES,FXD,MET FILM;3.32K OHM,1%,0.2W,TC=100 PPM	91637	CCF50-1-G33200F
A3R480	322-3235-00			RES,FXD,MET FILM;2.74K OHM,1%,0.2W,TC=100 PPM	57668	CRB20 FXE 2K74
A3R481	322-3001-00			RES,FXD,MET FILM;10 OHM,1%,0.2W,TC=100 PPM;AXIAL	80009	322-3001-00
A3R482	321-0156-00			RES,FXD,FILM:412 OHM,1%,0.125W,TC=T0	07716	CEAD412R0F
A3R483	321-0156-00			RES,FXD,FILM:412 OHM,1%,0.125W,TC=T0	07716	CEAD412R0F
A3R484	322-3322-00			RES,FXD,MET FILM;22.1K OHM,1%,0.2W,TC=100 PPM	80009	322-3322-00
A3R485	321-0062-00			RES,FXD,FILM:43.2 OHM,0.5%,0.125W,TC=T0	80009	321-0062-00
A3R486	322-3081-00			RES,FXD,MET FILM;68.1 OHM,1%,0.2W,TC=100 PPM;AXIAL	80009	322-3081-00
A3R487	322-3222-00			RES,FXD,MET FILM;2K OHM,1%,0.2W,TC=100 PPM	57668	CRB20 FXE 2K00
A3R489	311-2230-00			RES,VAR,TRMR:CERMET;500 OHM,20%,0.5W,0.197 SQ	TK1450	GF06UT 500
A3R491	322-3410-00			RES,FXD,MET FILM;182K OHM,1%,0.2W,TC=100 PPM;AXIAL	80009	322-3410-00
A3R492	311-0614-00			RES,VAR,NONWW:TRMR,30K OHM,0.5W	80009	311-0614-00
A3R493	322-3097-00			RES,FXD,MET FILM;100 OHM,1%,0.2W,TC=100 PPM;AXIAL	57668	CRB20 FXE 100E
A3R495	322-3289-00			RES,FXD,MET FILM;10K OHM,1%,0.2W,TC=100 PPM;AXIAL	80009	322-3289-00
A3R497	322-3147-00			RES,FXD,MET FILM;332 OHM,1%,0.2W,TC=100 PPM;AXIAL	80009	322-3147-00
A3R498	322-3097-00			RES,FXD,MET FILM;100 OHM,1%,0.2W,TC=100 PPM;AXIAL	57668	CRB20 FXE 100E
A3R499	322-3243-00			RES,FXD,MET FILM;3.32K OHM,1%,0.2W,TC=100 PPM	91637	CCF50-1-G33200F
A3R500	311-2265-00			RES,VAR,NONWW:TRMR,200K OHM,20%,0.5W	80009	311-2265-00
A3R503	322-3277-00			RES,FXD,FILM:7.5K OHM,1%,0.2W,TC=T0	57668	CRB20 FXE 7K50
A3R504	322-3193-00			RES,FXD,MET FILM;1K OHM,1%,0.2W,TC=100 PPM;AXIAL	57668	CRB20 FXE 1K00
A3R505	322-3193-00			RES,FXD,MET FILM;1K OHM,1%,0.2W,TC=100 PPM;AXIAL	57668	CRB20 FXE 1K00
A3R506	322-3193-00			RES,FXD,MET FILM;1K OHM,1%,0.2W,TC=100 PPM;AXIAL	57668	CRB20 FXE 1K00
A3R507	322-3193-00			RES,FXD,MET FILM;1K OHM,1%,0.2W,TC=100 PPM;AXIAL	57668	CRB20 FXE 1K00
A3R526	322-3147-00			RES,FXD,MET FILM;332 OHM,1%,0.2W,TC=100 PPM;AXIAL	80009	322-3147-00
A3R532	322-3318-00			RES,FXD,MET FILM;20K OHM,1%,0.2W,TC=100 PPM;AXIAL	57668	CRB20 FXE 20K0
A3R538	322-3289-00			RES,FXD,MET FILM;10K OHM,1%,0.2W,TC=100 PPM;AXIAL	80009	322-3289-00
A3R539	322-3289-00			RES,FXD,MET FILM;10K OHM,1%,0.2W,TC=100 PPM;AXIAL	80009	322-3289-00
A3R540	322-3343-00			RES,FXD,FILM:36.5K OHM,1%,0.2W,TC=T0	80009	322-3343-00

1730-Series Replaceable Electrical Parts

Component Number	Tektronix Part Number	Serial / Assembly Number		Name & Description	Mfr. Code	Mfr. Part Number
		Effective	Discontinued			
A3R541	322-3318-00			RES,FXD:MET FILM;20K OHM,1%,0.2W,TC=100 PPM;AXIAL	57668	CRB20 FXE 20K0
A3R542	322-3354-00			RES,FXD:MET FILM;47.5K OHM,1%,0.2W,TC=100 PPM	80009	322-3354-00
A3R543	315-0106-00			RES,FXD,FILM:10M OHM,5%,0.25W	01121	CB1065
A3R544	322-3246-00			RES,FXD,FILM:3.57K OHM,1%,0.2W,TC=T0	80009	322-3246-00
A3R545	322-3277-00			RES,FXD,FILM:7.5K OHM,1%,0.2W,TC=T0	57668	CRB20 FXE 7K50
A3R546	322-3162-00			RES,FXD:MET FILM;475 OHM,1%,0.2W,TC=100 PPM;AXIAL	80009	322-3162-00
A3R547	322-3258-00			RES,FXD:MET FILM;4.75K OHM,1%,0.2W,TC=100 PPM	80009	322-3258-00
A3R548	322-3339-00			RES,FXD:MET FILM;33.2K OHM,1%,0.2W,TC=100 PPM	80009	322-3339-00
A3R549	322-3354-00			RES,FXD:MET FILM;47.5K OHM,1%,0.2W,TC=100 PPM	80009	322-3354-00
A3R550	322-3034-00			RES,FXD:MET FILM;22.1 OHM,1%,0.2W,TC=100 PPM;AXIAL	57668	CRB20FXE2K94
A3R551	322-3329-00			RES,FXD,FILM:26.1K OHM,1%,0.2W,TC=T0	57668	CRB20 FXE 26K1
A3R553	311-2226-00			RES,VAR,NONWWW:TRMR,50 OHM,20%,0.5W LIN T&R	TK1450	GF06UT 50 OHM
A3R554	321-0089-00			RES,FXD,FILM:82.5 OHM,1%,0.125W,TC=T0	80009	321-0089-00
A3R555	321-0029-00			RES,FXD,FILM:19.6 OHM,1%,0.125W,TC=T0	80009	321-0029-00
A3R556	322-3322-00			RES,FXD:MET FILM;22.1K OHM,1%,0.2W,TC=100 PPM	80009	322-3322-00
A3R557	322-3218-00			RES,FXD:MET FILM;1.82K OHM,1%,0.2W,TC=100 PPM	80009	322-3218-00
A3R558	322-3218-00			RES,FXD:MET FILM;1.82K OHM,1%,0.2W,TC=100 PPM	80009	322-3218-00
A3R559	322-3200-00			RES,FXD,FILM:1.18K OHM,1%,0.2W,TC=T0	80009	322-3200-00
A3R562	322-3251-00			RES,FXD,FILM:4.02K OHM,1%,0.2W,TC=T0	57668	CRB20 FXE 4K02
A3R563	322-3226-00			RES,FXD:MET FILM;2.21K OHM,1%,0.2W,TC=100 PPM	57668	CRB20 FXE 2K21
A3R564	322-3097-00			RES,FXD:MET FILM;100 OHM,1%,0.2W,TC=100 PPM;AXIAL	57668	CRB20 FXE 100E
A3R565	322-3289-00			RES,FXD:MET FILM;10K OHM,1%,0.2W,TC=100 PPM;AXIAL	80009	322-3289-00
A3R566	321-0380-00			RES,FXD,FILM:88.7K OHM,1%,0.125W,TC=T0	07716	CEAD88701F
A3R567	322-3258-00			RES,FXD:MET FILM;4.75K OHM,1%,0.2W,TC=100 PPM	80009	322-3258-00
A3R569	322-3418-00			RES,FXD:MET FILM;221K OHM,1%,0.2W,TC=100 PPM	57668	CRB20 FXE 221K
A3R570	322-3210-00			RES,FXD:MET FILM;1.5K OHM,1%,0.2W,TC=100 PPM;AXIAL	57668	CRB20 FXE 1K50
A3R571	322-3306-00			RES,FXD:MET FILM;15K OHM,1%,0.2W,TC=100 PPM;AXIAL	57668	CRB20 FXE 15K0
A3R572	322-3066-00			RES,FXD:MET FILM;47.5 OHM,1%,0.2W,TC=100 PPM;AXIAL	09969	CCF502G47R50F
A3R573	322-3204-00			RES,FXD,FILM:1.3K OHM,1%,0.2W,TC=T0	80009	322-3204-00
A3R574	322-3204-00			RES,FXD,FILM:1.3K OHM,1%,0.2W,TC=T0	80009	322-3204-00
A3R575	322-3216-00			RES,FXD,FILM:1.74K OHM,1%,0.2W,TC=T0	57668	CRB20 FXE 1K74
A3R576	322-3175-00			RES,FXD,FILM:649 OHM,1%,0.2W,TC=T0	80009	322-3175-00
A3R577	322-3066-00			RES,FXD:MET FILM;47.5 OHM,1%,0.2W,TC=100 PPM;AXIAL	09969	CCF502G47R50F
A3R578	322-3242-00			RES,FXD,FILM:3.24K OHM,1%,0.2W,TC=T0	57668	CRB20 FXE 3K24
A3R579	322-3235-00			RES,FXD:MET FILM;2.74K OHM,1%,0.2W,TC=100 PPM	57668	CRB20 FXE 2K74
A3R580	322-3206-00			RES,FXD,FILM:1.37K OHM,1%,0.2W,TC=T0	80009	322-3206-00
A3R581	322-3001-00			RES,FXD:MET FILM;10 OHM,1%,0.2W,TC=100 PPM;AXIAL	80009	322-3001-00
A3R582	322-3333-02			RES,FXD,FILM:28.7K OHM,0.2W,.5%,T&R,SM BODY	80009	322-3333-02
A3R583	322-3367-00			RES,FXD,FILM:64.9K OHM,1%,0.2W,TC=T0	80009	322-3367-00
A3R584	322-3367-00			RES,FXD,FILM:64.9K OHM,1%,0.2W,TC=T0	80009	322-3367-00
A3R588	322-3242-00			RES,FXD,FILM:3.24K OHM,1%,0.2W,TC=T0	57668	CRB20 FXE 3K24
A3R589	322-3289-00			RES,FXD:MET FILM;10K OHM,1%,0.2W,TC=100 PPM;AXIAL	80009	322-3289-00
A3R590	322-3260-00			RES,FXD,FILM:4.99K OHM,1%,0.2W,TC=T0	57668	CRB20 FXE 4K99
A3R591	322-3297-00			RES,FXD:MET FILM;12.1K OHM,1%,0.2W,TC=100 PPM	57668	CRB20 FXE 12K1
A3R592	322-3097-00			RES,FXD:MET FILM;100 OHM,1%,0.2W,TC=100 PPM;AXIAL	57668	CRB20 FXE 100E
A3R593	322-3235-00			RES,FXD:MET FILM;2.74K OHM,1%,0.2W,TC=100 PPM	57668	CRB20 FXE 2K74
A3R594	322-3250-00			RES,FXD:MET FILM;3.92K OHM,1%,0.2W,TC=100 PPM	91637	CCF50-2F39200F
A3R595	322-3210-00			RES,FXD:MET FILM;1.5K OHM,1%,0.2W,TC=100 PPM;AXIAL	57668	CRB20 FXE 1K50
A3R596	321-0603-07			RES,FXD,FILM:15K OHM,0.1%,0.125W,TC=T9	80009	321-0603-07
A3R597	322-3318-00			RES,FXD:MET FILM;20K OHM,1%,0.2W,TC=100 PPM;AXIAL	57668	CRB20 FXE 20K0
A3R598	322-3239-00			RES,FXD,FILM:3.01K OHM,1%,0.2W,TC=T0	57668	CRB20 FXE 3K01
A3R599	315-0821-00			RES,FXD,FILM:820 OHM,5%,0.25W	80009	315-0821-00
A3R600	311-2269-00			RES,VAR,NONWWW:TRMR,20K OHM,20%,0.5W	80009	311-2269-00
A3R603	322-3001-00			RES,FXD:MET FILM;10 OHM,1%,0.2W,TC=100 PPM	80009	322-3001-00
A3R608	322-3339-00			RES,FXD:MET FILM;33.2K OHM,1%,0.2W,TC=100 PPM	80009	322-3339-00
A3R609	322-3147-00			RES,FXD:MET FILM;332 OHM,1%,0.2W,TC=100 PPM;AXIAL	80009	322-3147-00
A3R627	322-3097-00			RES,FXD:MET FILM;100 OHM,1%,0.2W,TC=100 PPM;AXIAL	57668	CRB20 FXE 100E
A3R636	311-2238-00			RES,VAR,TRMR:CERMET;50K OHM,20%,0.5W,0.197 SQ	TK1450	GF06UT 50 K

1730-Series Replaceable Electrical Parts

Component Number	Tektronix Part Number	Serial / Assembly Number		Name & Description	Mfr. Code	Mfr. Part Number
		Effective	Discontinued			
A3R637	322-3235-00			RES,FXD:MET FILM;2.74K OHM,1%,0.2W,TC=100 PPM	57668	CRB20 FXE 2K74
A3R638	322-3354-00			RES,FXD:MET FILM;47.5K OHM,1%,0.2W,TC=100 PPM	80009	322-3354-00
A3R639	322-3404-00			RES,FXD,FILM:158K OHM,1%,0.2W,TC=T0	91637	CCF50-2F15802F
A3R640	322-3418-00			RES,FXD:MET FILM;221K OHM,1%,0.2W,TC=100 PPM	57668	CRB20 FXE 221K
A3R641	322-3318-00			RES,FXD:MET FILM;20K OHM,1%,0.2W,TC=100 PPM;AXIAL	57668	CRB20 FXE 20K0
A3R642	322-3162-00			RES,FXD:MET FILM;475 OHM,1%,0.2W,TC=100 PPM;AXIAL	80009	322-3162-00
A3R643	322-3354-00			RES,FXD:MET FILM;47.5K OHM,1%,0.2W,TC=100 PPM	80009	322-3354-00
A3R644	322-3258-00			RES,FXD:MET FILM;4.75K OHM,1%,0.2W,TC=100 PPM	80009	322-3258-00
A3R646	322-3258-00			RES,FXD:MET FILM;4.75K OHM,1%,0.2W,TC=100 PPM	80009	322-3258-00
A3R647	322-3410-00			RES,FXD:MET FILM;182K OHM,1%,0.2W,TC=100 PPM;AXIAL	80009	322-3410-00
A3R648	322-3452-00			RES,FXD,FILM:499K OHM,1%,0.2W,TC=T0	91637	CCF50-2-G4993FT
A3R649	322-3356-00			RES,FXD,FILM:49.9K OHM,1%,0.2W,TC=T0	80009	322-3356-00
A3R650	322-3318-00			RES,FXD:MET FILM;20K OHM,1%,0.2W,TC=100 PPM;AXIAL	57668	CRB20 FXE 20K0
A3R651	322-3322-00			RES,FXD:MET FILM;22.1K OHM,1%,0.2W,TC=100 PPM	80009	322-3322-00
A3R652	322-3354-00			RES,FXD:MET FILM;47.5K OHM,1%,0.2W,TC=100 PPM	80009	322-3354-00
A3R653	322-3222-00			RES,FXD:MET FILM;2K OHM,1%,0.2W,TC=100 PPM;AXIAL	57668	CRB20 FXE 2K00
A3R654	322-3220-00			RES,FXD,FILM:1.91K OHM,1%,0.2W,TC=T0	80009	322-3220-00
A3R655	322-3310-00			RES,FXD,FILM:16.5K OHM,1%,0.2W,TC=T0	57668	CRB20 FXE 16K5
A3R656	321-0380-00			RES,FXD,FILM:88.7K OHM,1%,0.125W,TC=T0	07716	CEAD88701F
A3R657	322-3251-00			RES,FXD,FILM:4.02K OHM,1%,0.2W,TC=T0	57668	CRB20 FXE 4K02
A3R658	322-3200-00			RES,FXD,FILM:1.18K OHM,1%,0.2W,TC=T0	80009	322-3200-00
A3R659	322-3066-00			RES,FXD:MET FILM;47.5 OHM,1%,0.2W,TC=100 PPM;AXIAL	09969	CCF502G47R50F
A3R660	311-2234-00			RES,VAR,TRMR:CERMET;5K OHM,20%,0.5W,0.197 SQ	TK1450	GF06UT 5K
A3R661	311-2234-00			RES,VAR,TRMR:CERMET;5K OHM,20%,0.5W,0.197 SQ	TK1450	GF06UT 5K
A3R662	322-3322-00			RES,FXD:MET FILM;22.1K OHM,1%,0.2W,TC=100 PPM	80009	322-3322-00
A3R663	322-3481-00			RES,FXD,FILM:1M OHM,1%,0.2W,TC=T0	80009	322-3481-00
A3R664	322-3165-00			RES,FXD,FILM:511 OHM,1%,0.2W,TC=T0	57668	CRB20 FXE 511E
A3R665	322-3258-00			RES,FXD:MET FILM;4.75K OHM,1%,0.2W,TC=100 PPM	80009	322-3258-00
A3R666	322-3322-00			RES,FXD:MET FILM;22.1K OHM,1%,0.2W,TC=100 PPM	80009	322-3322-00
A3R669	322-3377-00			RES,FXD:MET FILM;82.5K OHM,1%,0.2W,TC=100 PPM	91637	CCF50-2F82501F
A3R670	322-3222-00			RES,FXD:MET FILM;2K OHM,1%,0.2W,TC=100 PPM;AXIAL	57668	CRB20 FXE 2K00
A3R671	322-3239-00			RES,FXD,FILM:3.01K OHM,1%,0.2W,TC=T0	57668	CRB20 FXE 3K01
A3R672	322-3193-00			RES,FXD:MET FILM;1K OHM,1%,0.2W,TC=100 PPM;AXIAL	57668	CRB20 FXE 1K00
A3R673	322-3222-00			RES,FXD:MET FILM;2K OHM,1%,0.2W,TC=100 PPM;AXIAL	57668	CRB20 FXE 2K00
A3R674	322-3222-00			RES,FXD:MET FILM;2K OHM,1%,0.2W,TC=100 PPM;AXIAL	57668	CRB20 FXE 2K00
A3R675	322-3172-00			RES,FXD,FILM:604 OHM,1%,0.2W,TC=T0	57668	CRB20 FXE 604E
A3R676	322-3289-00			RES,FXD:MET FILM;10K OHM,1%,0.2W,TC=100 PPM;AXIAL	80009	322-3289-00
A3R677	322-3297-00			RES,FXD:MET FILM;12.1K OHM,1%,0.2W,TC=100 PPM	57668	CRB20 FXE 12K1
A3R678	322-3335-00			RES,FXD,FILM:30.1K OHM,1%,0.2W,TC=T0	57668	CRB20 FXE 30K1
A3R679	322-3335-00			RES,FXD,FILM:30.1K OHM,1%,0.2W,TC=T0	57668	CRB20 FXE 30K1
A3R680	311-2232-00			RES,VAR,TRMR:CERMET,2K OHM,20%,0.5W,0.197 SQ	TK1450	GF06UT 2K
A3R681	322-3346-00			RES,FXD:MET FILM;39.2K OHM,1%,0.2W,TC=100 PPM	80009	322-3346-00
A3R682	322-3179-00			RES,FXD,FILM:715 OHM,1%,0.2W,TC=T0	80009	322-3179-00
A3R683	311-2233-00			RES,VAR,TRMR:CERMET;3K OHM,20%,0.5W,0.197 SQ	80009	311-2233-00
A3R687	322-3275-00			RES,FXD,FILM:7.15K OHM,1%,0.2W,TC=T0	80009	322-3275-00
A3R688	322-3268-00			RES,FXD,FILM:6.04K OHM,1%,0.2W,TC=T0	80009	322-3268-00
A3R689	311-2234-00			RES,VAR,TRMR:CERMET;5K OHM,20%,0.5W,0.197 SQ	TK1450	GF06UT 5K
A3R690	322-3297-00			RES,FXD:MET FILM;12.1K OHM,1%,0.2W,TC=100 PPM	57668	CRB20 FXE 12K1
A3R691	322-3297-00			RES,FXD:MET FILM;12.1K OHM,1%,0.2W,TC=100 PPM	57668	CRB20 FXE 12K1
A3R692	322-3239-00			RES,FXD,FILM:3.01K OHM,1%,0.2W,TC=T0	57668	CRB20 FXE 3K01
A3R693	322-3164-00			RES,FXD,FILM:499 OHM,1%,0.2W,TC=T0	57668	CRB20 FXE 499E
A3R694	322-3193-00			RES,FXD:MET FILM;1K OHM,1%,0.2W,TC=100 PPM;AXIAL	57668	CRB20 FXE 1K00
A3R695	322-3164-00			RES,FXD,FILM:499 OHM,1%,0.2W,TC=T0	57668	CRB20 FXE 499E
A3R696	321-0603-07			RES,FXD,FILM:15K OHM,0.1%,0.125W,TC=T9	80009	321-0603-07
A3R697	322-3410-00			RES,FXD:MET FILM;182K OHM,1%,0.2W,TC=100 PPM	80009	322-3410-00
A3R698	322-3034-00			RES,FXD:MET FILM;22.1 OHM,1%,0.2W,TC=100 PPM	57668	CRB20FXE2K94
A3R700	311-2269-00			RES,VAR,NONWW:TRMR,20K OHM,20%,0.5W	80009	311-2269-00
A3R701	311-2269-00			RES,VAR,NONWW:TRMR,20K OHM,20%,0.5W	80009	311-2269-00

1730-Series Replaceable Electrical Parts

Component Number	Tektronix Part Number	Serial / Assembly Number		Name & Description	Mfr. Code	Mfr. Part Number
		Effective	Discontinued			
A3R732	307-0446-00			RES NTWK,FXD,FI:10K OHM,20%,(9)RES	80009	307-0446-00
A3R734	322-3289-00			RES,FXD:MET FILM:10K OHM,1%,0.2W,TC=100 PPM	80009	322-3289-00
A3R736	307-0696-00			RES NTWK,FXD,FI:7,10K OHM,2%,0.15W EACH	80009	307-0696-00
A3R740	322-3322-00			RES,FXD:MET FILM:22.1K OHM,1%,0.2W,TC=100 PPM	80009	322-3322-00
A3R741	322-3235-00			RES,FXD:MET FILM:2.74K OHM,1%,0.2W,TC=100 PPM	57668	CRB20 FXE 2K74
A3R742	322-3412-00			RES,FXD,FILM:191K OHM,1%,0.2W,TC=T0	80009	322-3412-00
A3R743	322-3412-00			RES,FXD,FILM:191K OHM,1%,0.2W,TC=T0	80009	322-3412-00
A3R746	322-3258-00			RES,FXD:MET FILM:4.75K OHM,1%,0.2W,TC=100 PPM	80009	322-3258-00
A3R750	322-3412-00			RES,FXD,FILM:191K OHM,1%,0.2W,TC=T0	80009	322-3412-00
A3R751	322-3354-00			RES,FXD:MET FILM:47.5K OHM,1%,0.2W,TC=100 PPM	80009	322-3354-00
A3R752	321-0337-00			RES,FXD,FILM:31.6K OHM,1%,0.125W,TC=T0	07716	CEAD31601F
A3R753	321-0429-00			RES,FXD,FILM:287K OHM,1%,0.125W,TC=T0	07716	CEAD28702F
A3R754	322-3402-00			RES,FXD:MET FILM:150K OHM,1%,0.2W,TC=100 PPM;AXIAL	80009	322-3402-00
A3R755	322-3189-00			RES,FXD,FILM:909 OHM,1%,0.2W,TC=T0	57668	CRB 20 FXE 909E
A3R756	322-3285-00			RES,FXD,FILM:9.09K OHM,1%,0.2W,TC=T0	80009	322-3285-00
A3R757	322-3308-00			RES,FXD,FILM:15.8K OHM,1%,0.2W,TC=T0	80009	322-3308-00
A3R758	322-3308-00			RES,FXD,FILM:15.8K OHM,1%,0.2W,TC=T0	80009	322-3308-00
A3R759	322-3179-00			RES,FXD,FILM:715 OHM,1%,0.2W,TC=T0	80009	322-3179-00
A3R761	321-0172-00			RES,FXD,FILM:604 OHM,1%,0.125W,TC=T0	80009	321-0172-00
A3R762	321-0172-00			RES,FXD,FILM:604 OHM,1%,0.125W,TC=T0	80009	321-0172-00
A3R764	322-3289-00			RES,FXD:MET FILM:10K OHM,1%,0.2W,TC=100 PPM;AXIAL	80009	322-3289-00
A3R765	322-3414-00			RES,FXD:MET FILM:200K OHM,1%,0.2W,TC=100 PPM;AXIAL	91637	CCF501G20002F
A3R766	321-0300-00			RES,FXD,FILM:13.0K OHM,1%,0.125W,TC=T0	07716	CEAD13001F
A3R767	322-3293-00			RES,FXD:MET FILM:11K OHM,1%,0.2W,TC=100 PPM;AXIAL,T&R,SM BODY	80009	322-3293-00
A3R768	322-3352-00			RES,FXD,FILM:45.3K OHM,1%,0.2W,TC=T0	57668	CRB20 FXE 45K3
A3R771	322-3239-00			RES,FXD,FILM:3.01K OHM,1%,0.2W,TC=T0	57668	CRB20 FXE 3K01
A3R772	322-3297-00			RES,FXD:MET FILM:12.1K OHM,1%,0.2W,TC=100 PPM	57668	CRB20 FXE 12K1
A3R773	322-3268-00			RES,FXD,FILM:6.04K OHM,1%,0.2W,TC=T0	80009	322-3268-00
A3R774	322-3339-00			RES,FXD:MET FILM:33.2K OHM,1%,0.2W,TC=100 PPM	80009	322-3339-00
A3R775	322-3097-00			RES,FXD:MET FILM:100 OHM,1%,0.2W,TC=100 PPM;AXIAL	57668	CRB20 FXE 100E
A3R776	322-3193-00			RES,FXD:MET FILM:1K OHM,1%,0.2W,TC=100 PPM;AXIAL	57668	CRB20 FXE 1K00
A3R777	322-3385-00			RES,FXD:MET FILM:100K OHM,1%,0.2W,TC=100 PPM;AXIAL	57668	CRB20 FXE 100K
A3R783	322-3222-00			RES,FXD:MET FILM:2K OHM,1%,0.2W,TC=100 PPM;AXIAL	57668	CRB20 FXE 2K00
A3R784	322-3385-00			RES,FXD:MET FILM:100K OHM,1%,0.2W,TC=100 PPM;AXIAL	57668	CRB20 FXE 100K
A3R792	322-3164-00			RES,FXD,FILM:499 OHM,1%,0.2W,TC=T0	57668	CRB20 FXE 499E
A3R793	322-3297-00			RES,FXD:MET FILM:12.1K OHM,1%,0.2W,TC=100 PPM	57668	CRB20 FXE 12K1
A3R794	322-3234-00			RES,FXD,FILM:2.67K OHM,1%,0.2W,TC=T0	91637	CCF50-2F26700F
A3R795	322-3289-00			RES,FXD:MET FILM:10K OHM,1%,0.2W,TC=100 PPM;AXIAL	80009	322-3289-00
A3R796	322-3258-00			RES,FXD:MET FILM:4.75K OHM,1%,0.2W,TC=100 PPM	80009	322-3258-00
A3R797	322-3254-00			RES,FXD,FILM:4.32K OHM,1%,0.2W,TC=T0	80009	322-3254-00
A3R805	322-3385-00			RES,FXD:MET FILM:100K OHM,1%,0.2W,TC=100 PPM;AXIAL	57668	CRB20 FXE 100K
A3R823	322-3326-00			RES,FXD,FILM:24.3K OHM,1%,0.2W,TC=T0	91637	CCF50-2F24301F
A3R824	322-3251-00			RES,FXD,FILM:4.02K OHM,1%,0.2W,TC=T0	57668	CRB20 FXE 4K02
A3R825	322-3254-00			RES,FXD,FILM:4.32K OHM,1%,0.2W,TC=T0	80009	322-3254-00
A3R826	322-3402-00			RES,FXD:MET FILM:150K OHM,1%,0.2W,TC=100 PPM;AXIAL	80009	322-3402-00
A3R827	322-3402-00			RES,FXD:MET FILM:150K OHM,1%,0.2W,TC=100 PPM;AXIAL	80009	322-3402-00
A3R834	322-3097-00			RES,FXD:MET FILM:100 OHM,1%,0.2W,TC=100 PPM;AXIAL	57668	CRB20 FXE 100E
A3R835	315-0225-00			RES,FXD,FILM:2.2M OHM,5%,0.25W	01121	CB2255
A3R836	315-0225-00			RES,FXD,FILM:2.2M OHM,5%,0.25W	01121	CB2255
A3R837	322-3310-00			RES,FXD,FILM:16.5K OHM,1%,0.2W,TC=T0	57668	CRB20 FXE 16K5
A3R838	322-3001-00			RES,FXD:MET FILM:10 OHM,1%,0.2W,TC=100 PPM;AXIAL	80009	322-3001-00
A3R839	322-3193-00			RES,FXD:MET FILM:1K OHM,1%,0.2W,TC=100 PPM;AXIAL	57668	CRB20 FXE 1K00
A3R840	322-3222-00			RES,FXD:MET FILM:2K OHM,1%,0.2W,TC=100 PPM;AXIAL	57668	CRB20 FXE 2K00
A3R845	322-3354-00			RES,FXD:MET FILM:47.5K OHM,1%,0.2W,TC=100 PPM	80009	322-3354-00
A3R846	322-3293-00			RES,FXD:MET FILM:11K OHM,1%,0.2W,TC=100 PPM;AXIAL	80009	322-3293-00
A3R847	322-3234-00			RES,FXD,FILM:2.67K OHM,1%,0.2W,TC=T0	91637	CCF50-2F26700F
A3R848	322-3258-00			RES,FXD:MET FILM:4.75K OHM,1%,0.2W,TC=100 PPM	80009	322-3258-00

1730-Series Replaceable Electrical Parts

Component Number	Tektronix Part Number	Serial / Assembly Number		Name & Description	Mfr. Code	Mfr. Part Number
		Effective	Discontinued			
A3R849	321-0317-00			RES,FXD,FILM:19.6K OHM,1%,0.125W,TC=T0	07716	CEAD19601F
A3R850	322-3354-00			RES,FXD:MET FILM:47.5K OHM,1%,0.2W,TC=100 PPM	80009	322-3354-00
A3R851	322-3289-00			RES,FXD:MET FILM:10K OHM,1%,0.2W,TC=100 PPM;AXIAL	80009	322-3289-00
A3R852	322-3193-00			RES,FXD:MET FILM:1K OHM,1%,0.2W,TC=100 PPM;AXIAL	57668	CRB20 FXE 1K00
A3R853	322-3293-00			RES,FXD:MET FILM:11K OHM,1%,0.2W,TC=100 PPM;AXIAL	80009	322-3293-00
A3R854	321-0452-00			RES,FXD,FILM:499K OHM,1%,0.125W,TC=T0	80009	321-0452-00
A3R855	322-3354-00			RES,FXD:MET FILM:47.5K OHM,1%,0.2W,TC=100 PPM	80009	322-3354-00
A3R856	311-2236-00			RES,VAR,TRMR: CERMET;20K OHM,20%,0.5W,0.197 SQ	TK1450	GF06UT 20K
A3R857	322-3308-00			RES,FXD,FILM:15.8K OHM,1%,0.2W,TC=T0	80009	322-3308-00
A3R858	322-3308-00			RES,FXD,FILM:15.8K OHM,1%,0.2W,TC=T0	80009	322-3308-00
A3R859	321-0300-00			RES,FXD,FILM:13.0K OHM,1%,0.125W,TC=T0	07716	CEAD13001F
A3R860	322-3293-00			RES,FXD:MET FILM:11K OHM,1%,0.2W,TC=100 PPM;AXIAL	80009	322-3293-00
A3R861	322-3318-00			RES,FXD:MET FILM:20K OHM,1%,0.2W,TC=100 PPM;AXIAL	57668	CRB20 FXE 20K0
A3R865	322-3233-00			RES,FXD,FILM:2.61K OHM,1%,0.2W,TC=T0	80009	322-3233-00
A3R866	322-3097-00			RES,FXD:MET FILM:100 OHM,1%,0.2W,TC=100 PPM;AXIAL	57668	CRB20 FXE 100E
A3R867	322-3097-00			RES,FXD:MET FILM:100 OHM,1%,0.2W,TC=100 PPM;AXIAL	57668	CRB20 FXE 100E
A3R868	322-3233-00			RES,FXD,FILM:2.61K OHM,1%,0.2W,TC=T0	80009	322-3233-00
A3R870	322-3193-00			RES,FXD:MET FILM:1K OHM,1%,0.2W,TC=100 PPM;AXIAL	57668	CRB20 FXE 1K00
A3R871	322-3385-00			RES,FXD:MET FILM:100K OHM,1%,0.2W,TC=100 PPM;AXIAL	57668	CRB20 FXE 100K
A3R873	322-3001-00			RES,FXD:MET FILM:10 OHM,1%,0.2W,TC=100 PPM;AXIAL	80009	322-3001-00
A3R874	322-3258-00			RES,FXD:MET FILM:4.75K OHM,1%,0.2W,TC=100 PPM	80009	322-3258-00
A3R875	322-3258-00			RES,FXD:MET FILM:4.75K OHM,1%,0.2W,TC=100 PPM	80009	322-3258-00
A3R876	322-3207-00			RES,FXD,FILM:1.4K OHM,1%,0.2W,TC=T0	57668	CRB20 FXE 1K4
A3R878	322-3289-00			RES,FXD:MET FILM:10K OHM,1%,0.2W,TC=100 PPM;AXIAL	80009	322-3289-00
A3R881	322-3258-00			RES,FXD:MET FILM:4.75K OHM,1%,0.2W,TC=100 PPM	80009	322-3258-00
A3R882	322-3097-00			RES,FXD:MET FILM:100 OHM,1%,0.2W,TC=100 PPM;AXIAL	57668	CRB20 FXE 100E
A3R883	322-3170-00			RES,FXD,FILM:576 OHM,1%,0.2W,TC=T0	80009	322-3170-00
A3R884	322-3274-00			RES,FXD,FILM:6.98K OHM,1%,0.2W,TC=T0	91637	CCF502G69800FT
A3R885	322-3385-00			RES,FXD:MET FILM:100K OHM,1%,0.2W,TC=100 PPM;AXIAL	57668	CRB20 FXE 100K
A3R887	322-3281-00			RES,FXD:MET FILM:8.25K OHM,1%,0.2W,TC=100 PPM	80009	322-3281-00
A3R888	322-3354-00			RES,FXD:MET FILM:47.5K OHM,1%,0.2W,TC=100 PPM	80009	322-3354-00
A3R889	322-3201-00			RES,FXD:MET FILM:1.21K OHM,1%,0.2W,TC=100 PPM	80009	322-3201-00
A3R890	322-3222-00			RES,FXD:MET FILM:2K OHM,1%,0.2W,TC=100 PPM;AXIAL	57668	CRB20 FXE 2K00
A3R891	322-3306-00			RES,FXD:MET FILM:15K OHM,1%,0.2W,TC=100 PPM;AXIAL	57668	CRB20 FXE 15K0
A3R892	322-3097-00			RES,FXD:MET FILM:100 OHM,1%,0.2W,TC=100 PPM;AXIAL	57668	CRB20 FXE 100E
A3R893	322-3226-00			RES,FXD:MET FILM:2.21K OHM,1%,0.2W,TC=100 PPM	57668	CRB20 FXE 2K21
A3R894	322-3243-00			RES,FXD:MET FILM:3.32K OHM,1%,0.2W,TC=100 PPM	91637	CCF50-1-G33200F
A3R895	322-3239-00			RES,FXD,FILM:3.01K OHM,1%,0.2W,TC=T0	57668	CRB20 FXE 3K01
A3R896	322-3258-00			RES,FXD:MET FILM:4.75K OHM,1%,0.2W,TC=100 PPM	80009	322-3258-00
A3R897	322-3226-00			RES,FXD:MET FILM:2.21K OHM,1%,0.2W,TC=100 PPM	57668	CRB20 FXE 2K21
A3R898	322-3306-00			RES,FXD:MET FILM:15K OHM,1%,0.2W,TC=100 PPM;AXIAL	57668	CRB20 FXE 15K0
A3R899	322-3289-00			RES,FXD:MET FILM:10K OHM,1%,0.2W,TC=100 PPM;AXIAL	80009	322-3289-00
A3R907	322-3318-00			RES,FXD:MET FILM:20K OHM,1%,0.2W,TC=100 PPM;AXIAL	57668	CRB20 FXE 20K0
A3R923	322-3258-00			RES,FXD:MET FILM:4.75K OHM,1%,0.2W,TC=100 PPM	80009	322-3258-00
A3R924	322-3354-00			RES,FXD:MET FILM:47.5K OHM,1%,0.2W,TC=100 PPM	80009	322-3354-00
A3R926	322-3289-00			RES,FXD:MET FILM:10K OHM,1%,0.2W,TC=100 PPM;AXIAL	80009	322-3289-00
A3R927	322-3097-00			RES,FXD:MET FILM:100 OHM,1%,0.2W,TC=100 PPM;AXIAL	57668	CRB20 FXE 100E
A3R938	322-3147-00			RES,FXD:MET FILM:332 OHM,1%,0.2W,TC=100 PPM;AXIAL	80009	322-3147-00
A3R939	322-3273-00			RES,FXD:MET FILM:6.81K OHM,1%,0.2W,TC=100 PPM	80009	322-3273-00
A3R944	321-0380-00			RES,FXD,FILM:88.7K OHM,1%,0.125W,TC=T0	07716	CEAD88701F
A3R947	322-3421-00			RES,FXD,FILM:237K OHM,1%,0.2W,TC=T0	91637	CCF50-2F23702F
A3R950	321-0317-00			RES,FXD,FILM:19.6K OHM,1%,0.125W,TC=T0	07716	CEAD19601F
A3R951	322-3066-00			RES,FXD:MET FILM:47.5 OHM,1%,0.2W,TC=100 PPM;AXIAL	09969	CCF502G47R50F
A3R953	322-3481-00			RES,FXD,FILM:1M OHM,1%,0.2W,TC=T0	80009	322-3481-00
A3R954	322-3435-00			RES,FXD:MET FILM:332K OHM,1%,0.2W,TC=100 PPM;AXIAL	80009	322-3435-00
A3R956	322-3258-00			RES,FXD:MET FILM:4.75K OHM,1%,0.2W,TC=100 PPM	80009	322-3258-00
A3R957	322-3318-00			RES,FXD:MET FILM:20K OHM,1%,0.2W,TC=100 PPM;AXIAL	57668	CRB20 FXE 20K0
A3R958	322-3385-00			RES,FXD:MET FILM:100K OHM,1%,0.2W,TC=100 PPM;AXIAL	57668	CRB20 FXE 100K

1730-Series Replaceable Electrical Parts

Component Number	Tektronix Part Number	Serial / Assembly Number		Name & Description	Mfr. Code	Mfr. Part Number
		Effective	Discontinued			
A3R959	322-3385-00			RES,FXD:MET FILM;100K OHM,1%,0.2W,TC=100 PPM;AXIAL	57668	CRB20 FXE 100K
A3R960	322-3385-00			RES,FXD:MET FILM;100K OHM,1%,0.2W,TC=100 PPM;AXIAL	57668	CRB20 FXE 100K
A3R963	322-3243-00			RES,FXD:MET FILM;3.32K OHM,1%,0.2W,TC=100 PPM	91637	CCF50-1-G33200F
A3R964	322-3481-00			RES,FXD,FILM:1M OHM.1%,0.2W,TC=T0	80009	322-3481-00
A3R965	322-3385-00			RES,FXD:MET FILM;100K OHM,1%,0.2W,TC=100 PPM;AXIAL	57668	CRB20 FXE 100K
A3R966	322-3354-00			RES,FXD:MET FILM;47.5K OHM,1%,0.2W,TC=100 PPM	80009	322-3354-00
A3R975	322-3246-00			RES,FXD,FILM:3.57K OHM,1%,0.2W,TC=T0	80009	322-3246-00
A3R976	322-3085-00			RES,FXD:MET FILM;75 OHM,1%,0.2W,TC=100 PPM;AXIAL	57668	CRB20 FXE 75E0
A3R977	301-0681-00			RES,FXD,FILM:680 OHM,5%,0.5W	01121	EB6815
A3R982	322-3066-00			RES,FXD:MET FILM;47.5 OHM,1%,0.2W,TC=100 PPM;AXIAL	09969	CCF502G47R50F
A3R983	322-3097-00			RES,FXD:MET FILM;100 OHM,1%,0.2W,TC=100 PPM;AXIAL	57668	CRB20 FXE 100E
A3R987	322-3273-00			RES,FXD:MET FILM;6.81K OHM,1%,0.2W,TC=100 PPM	80009	322-3273-00
A3R988	322-3322-00			RES,FXD:MET FILM;22.1K OHM,1%,0.2W,TC=100 PPM	80009	322-3322-00
A3R989	322-3250-00			RES,FXD:MET FILM;3.92K OHM,1%,0.2W,TC=100 PPM;	91637	CCF50-2F39200F
A3R990	322-3250-00			RES,FXD:MET FILM;3.92K OHM,1%,0.2W,TC=100 PPM	91637	CCF50-2F39200F
A3R991	322-3385-00			RES,FXD:MET FILM;100K OHM,1%,0.2W,TC=100 PPM;AXIAL	57668	CRB20 FXE 100K
A3R992	322-3418-00			RES,FXD:MET FILM;221K OHM,1%,0.2W,TC=100 PPM;AXIAL	57668	CRB20 FXE 221K
A3R993	322-3289-00			RES,FXD:MET FILM;10K OHM,1%,0.2W,TC=100 PPM;AXIAL	80009	322-3289-00
A3R994	322-3322-00			RES,FXD:MET FILM;22.1K OHM,1%,0.2W,TC=100 PPM	80009	322-3322-00
A3R997	322-3306-00			RES,FXD:MET FILM;15K OHM,1%,0.2W,TC=100 PPM;AXIAL	57668	CRB20 FXE 15K0
A3S404	260-2301-00			SW,PUSH: *ATTACHED PARTS*	34361	B3F3152
	366-0616-00			PUSH BTN:0.585 X 0.3 X 0.150 *END ATTACHED PARTS*	80009	366-0616-00
A3S504	260-2301-00			SW,PUSH: *ATTACHED PARTS*	34361	B3F3152
	366-0616-00			PUSH BTN:0.585 X 0.3 X 0.150 *END ATTACHED PARTS*	80009	366-0616-00
A3S604	260-2301-00			SW,PUSH: *ATTACHED PARTS*	34361	B3F3152
	366-0616-00			PUSH BTN:0.585 X 0.3 X 0.150 *END ATTACHED PARTS*	80009	366-0616-00
A3S704	260-2301-00			SW,PUSH: *ATTACHED PARTS*	34361	B3F3152
	366-0616-00			PUSH BTN:0.585 X 0.3 X 0.150 *END ATTACHED PARTS*	80009	366-0616-00
A3S804	260-2301-00			SW,PUSH: *ATTACHED PARTS*	34361	B3F3152
	366-0616-00			PUSH BTN:0.585 X 0.3 X 0.150 *END ATTACHED PARTS*	80009	366-0616-00
A3U164	156-1451-00			IC,LIN:BIPOLAR,VR;NEG,ADJUST,1.5A,4%;LM337T,TO-220	80009	156-1451-00
A3U172	156-1161-00			IC,LIN:BIPOLAR,VR;POS,ADJUST,1.5A,4%;LM317T,TO-220	04713	LM317T
A3U231	156-1191-00			IC,LIN:BIFET,OP-AMP;DUAL;TL072CN/LF353N,DIP08.3	80009	156-1191-00
A3U234	156-0941-00			IC,DGTL:CMOS,GATE;QUAD 2-INP NAND;74C00,DIP14.3,TUBE	27014	MM74C00 J OR N
A3U239	156-1225-00			IC,LIN:BIPOLAR,COMPTR;DUAL,OPEN COLL,300NS;LM393N,DIP08.3	01295	LM393P
A3U252	156-0048-00			IC,LIN:	80009	156-0048-00
A3U263	156-1225-00			IC,LIN:BIPOLAR,COMPTR;DUAL,OPEN COLL,300NS;LM393N,DIP08.3	01295	LM393P
A3U277	156-1850-00			IC,MISC:CMOS,ANLG SW;QUAD;DG211,DIP16.3	17856	SDG21107
A3U305	156-0259-00			IC,LIN:	80009	156-0259-00
A3U325	156-2493-00			IC,CONV:	80009	156-2493-00
A3U331	156-0910-00			IC,DGTL:LSTTL,CNTR;DUAL 4-BIT DE- CADE;74LS390,DIP16.3,TUBE	80009	156-0910-00
A3U334	156-0575-00			IC,DGTL:CMOS,GATE;TRIPLE 3-INP NOR;4025B,DIP14.3,TUBE	80009	156-0575-00
A3U395	156-1850-00			IC,MISC:CMOS,ANLG SW;QUAD;DG211,DIP16.3	17856	SDG21107

1730-Series Replaceable Electrical Parts

Component Number	Tektronix Part Number	Serial / Assembly Number		Name & Description	Mfr. Code	Mfr. Part Number
		Effective	Discontinued			
A3U407	156-1430-00			IC,DGTL:CMOS,MISC:4-DIGIT LED DSPLY CONT;74C911,DIP28.6,TUBE	27014	MM74C911 N
A3U445	156-1225-00			IC,LIN:BIPOLAR,COMPTR:DUAL,OPEN COLL,300NS;LM393N,DIP08.3	01295	LM393P
A3U465	156-1225-00			IC,LIN:BIPOLAR,COMPTR:DUAL,OPEN COLL,300NS;LM393N,DIP08.3	01295	LM393P
A3U488	156-1149-00			IC,LIN:BIFET,OP-AMP;LF351N,DIP08.3	27014	LF351N/GLEA134
A3U492	156-2460-00			IC,MISC:BIPOLAR,MOD/DEMOMOD;BAL;MC1496P,DIP14.3	04713	MC1496P
A3U495	156-1191-00			IC,LIN:BIFET,OP-AMP;DUAL;TL072CN/LF353N,DIP08.3	80009	156-1191-00
A3U522	160-3304-01	672-1229-14		MICROCKT,DGTL:8052 MICROCONT W/8K ROM,PRGM	80009	160-3304-01
A3U522	160-4316-00	672-1266-15		MICROCKT,DGTL:MICROPROCESSOR,EPROM,PRGM	80009	160-4316-00
A3U522	160-4528-00	672-0225-13		MICROCKT,DGTL:MICROPROCESSOR,EPROM,PRGM	80009	160-4528-00
A3U527	156-0913-00			IC,DGTL:LSTTL,FLIP FLOP;OCTAL D-TYPE, ENABLE;74LS377,DIP20.3,TUBE	80009	156-0913-00
A3U532	156-0913-00			IC,DGTL:LSTTL,FLIP FLOP;OCTAL D-TYPE, ENABLE;74LS377,DIP20.3,TUBE	80009	156-0913-00
A3U533	156-1221-00			IC,DGTL:LSTTL,FLIP FLOP;HEX D, POS EDGE TRIG, W/ENABLE;74LS378,DIP16.3,TUBE	80009	156-1221-00
A3U535	160-3662-01			IC,DGTL:STTL,PLD;PAL,16R4;16R4,DIP20.3	80009	160-3662-01
	136-0752-00			*MOUNTING PARTS*		
				SKT,PL-IN ELEK:MICROCKT,20 DIP	09922	DILB20P-108
				END MOUNTING PARTS		
A3U541	156-2009-00			IC,DGTL:HCMOS,FLIP FLOP;DUAL D-TYPE;74HC74,DIP14.3,TUBE	80009	156-2009-00
A3U552	156-1191-00			IC,LIN:BIFET,OP-AMP;DUAL;TL072CN/LF353N,DIP08.3	80009	156-1191-00
A3U564	156-0048-00			IC,LIN:	80009	156-0048-00
A3U578	156-2460-00			IC,MISC:BIPOLAR,MOD/DEMOMOD;BAL;MC1496P,DIP14.3	04713	MC1496P
A3U585	156-1850-00			IC,MISC:CMOS,ANLG SW;QUAD;DG211,DIP16.3	17856	SDG21107
A3U644	156-0704-00			IC,MISC:CMOS,PLL;LOW SP;MC14046BCP,DIP16.3	04713	MC14046CP
A3U655	156-1191-00			IC,LIN:BIFET,OP-AMP;DUAL;TL072CN/LF353N,DIP08.3	80009	156-1191-00
A3U690	156-0048-00			IC,LIN:	80009	156-0048-00
A3U725	156-2029-00			IC,MEM:NMOS,NVRAM;16 X 16, SER DATA;X2443,DIP8	60395	X2444P
A3U726	156-1126-00			IC,LIN:BIPOLAR,COMPTR;OPEN COLL,200NS;LM311N,DIP08.3	80009	156-1126-00
A3U731	156-0956-00			IC,DGTL:LSTTL,BFR/DRVOR;OCTAL NONINV, 3-STATE;74LS244,DIP20.3,TUBE	80009	156-0956-00
A3U735	160-3661-00			MICROCKT,DGTL:STTL,QUAD 16 INP RGTRED AND-OR GATW ARRAY	80009	160-3661-00
	136-0752-00			*MOUNTING PARTS*		
				SKT,PL-IN ELEK:MICROCKT,20 DIP	09922	DILB20P-108
				END MOUNTING PARTS		
A3U741	156-0750-03			IC,DGTL:CMOS,MULTIVIBRATOR;DUAL MONOST-ABLE;74C221,DIP16.3	27014	74C221N
A3U753	156-1225-00			IC,LIN:BIPOLAR,COMPTR;DUAL,OPEN COLL,300NS;LM393N,DIP08.3	01295	LM393P
A3U786	156-1850-00			IC,MISC:CMOS,ANLG SW;QUAD;DG211,DIP16.3	17856	SDG21107
A3U795	156-0048-00			IC,LIN:	80009	156-0048-00
A3U805	156-0941-00			IC,DGTL:CMOS,GATE;QUAD 2-INP NAND;74C00,DIP14.3,TUBE	27014	MM74C00 J OR N
A3U809	156-1373-00			IC,DGTL:LSTTL,BFR/DRVOR;QUAD, 3-STATE;74LS125,DIP14.3,TUBE	80009	156-1373-00
A3U841	156-0941-00			IC,DGTL:CMOS,GATE;QUAD 2-INP NAND;74C00,DIP14.3,TUBE	27014	MM74C00 J OR N
A3U844	156-0750-03			IC,DGTL:CMOS,MULTIVIBRATOR;DUAL MONOST-ABLE;74C221,DIP16.3	27014	74C221N
A3U884	156-1917-00			IC,DGTL:LSTTL,SHF RGTR;8-BIT W/OUT LCH;74LS595,DIP16.3,TUBE	80009	156-1917-00
A3U892	156-1381-00			IC,LIN:BIPOLAR,XSTR ARRAY;THREE NPN,TWO PNP,IN-DEP;CA3096AE,DIP16.3	02735	CA3096AE-17
A3U947	156-1191-00			IC,LIN:BIFET,OP-AMP;DUAL;TL072CN/LF353N,DIP08.3	80009	156-1191-00

1730-Series Replaceable Electrical Parts

Component Number	Tektronix Part Number	Serial / Assembly Number		Name & Description	Mfr. Code	Mfr. Part Number
		Effective	Discontinued			
A3U978	156-0048-00			IC,LIN:	80009	156-0048-00
A3VR273	152-0243-00			DIO,ZENER:15V,5%,0.4W;1N965B,DO-7 OR 35,TR	14433	Z5412
A3VR297	152-0175-00			DIO,ZENER:5.6V,5%,0.4W;1N752A,DO-7 OR 35,TR	14552	TD3810976
A3VR497	152-0175-00			DIO,ZENER:5.6V,5%,0.4W;1N752A,DO-7 OR 35,TR	14552	TD3810976
A3VR540	152-0688-00			DIO,ZENER:2.4V,5%,0.4W;1N4370A,DO-7 OR 35	04713	1N4370A
A3VR769	152-0359-00			DIO,ZENER:9V,500MW,5%,TEMP COMPENSATED;1N935,DO-35	04713	SZ50850
A3VR877	152-0175-00			DIO,ZENER:5.6V,5%,0.4W;1N752A,DO-7 OR 35,TR	14552	TD3810976
A3W99	131-0566-00			BUS,CNDCT:DUM RES,0.094 OD X 0.225 L	80009	131-0566-00
A3W709	131-0566-00			BUS,CNDCT:DUM RES,0.094 OD X 0.225 L	80009	131-0566-00
A3W786	131-0566-00			BUS,CNDCT:DUM RES,0.094 OD X 0.225 L	80009	131-0566-00
A3W886	131-0566-00			BUS,CNDCT:DUM RES,0.094 OD X 0.225 L	80009	131-0566-00
A3W921	131-0566-00			BUS,CNDCT:DUM RES,0.094 OD X 0.225 L	80009	131-0566-00
A3W922	131-0566-00			BUS,CNDCT:DUM RES,0.094 OD X 0.225 L	80009	131-0566-00
A3Y709	158-0300-00			XTAL UNIT,QTZ:12 MHZ,0.05%,SERIES RESN	80009	158-0300-00
A3A1	671-1796-01			CIRCUIT BD ASSY:GRATICULE LIGHT	80009	671-1796-01
A3A1DS100	150-0168-00			LAMP,INCAND:14V,0.08A,WG BASE,T1.75 FOR SKT MT	80009	150-0168-00
				MOUNTING PARTS		
	136-1119-01			SOCKET,LPHLDR:PCB,LAMPHOLDER,FEMALE,STR,SINGLE 0.404H X 0.218 TAILTIN, T-1.75 WEDGE BASE	80009	136-1119-01
				END MOUNTING PARTS		
A3A1DS200	150-0168-00			LAMP,INCAND:14V,0.08A,WG BASE,T1.75 FOR SKT MT	80009	150-0168-00
				MOUNTING PARTS		
	136-1119-01			SOCKET,LPHLDR:PCB,LAMPHOLDER,FEMALE,STR,SINGLE 0.404H X 0.218 TAILTIN, T-1.75 WEDGE BASE	80009	136-1119-01
				END MOUNTING PARTS		
A3A1DS300	150-0168-00			LAMP,INCAND:14V,0.08A,WG BASE,T1.75 FOR SKT MT	80009	150-0168-00
				MOUNTING PARTS		
	136-1119-01			SOCKET,LPHLDR:PCB,LAMPHOLDER,FEMALE,STR,SINGLE 0.404H X 0.218 TAILTIN, T-1.75 WEDGE BASE	80009	136-1119-01
				END MOUNTING PARTS		
A3A1J100	131-4530-00			CONN,HDR:	80009	131-4530-00
A3A1P100	131-3199-00			CONN,SHUNT:FEM,STR,1 X 2,0.1 CTR,0.2 H,LOW PF, JUMPER	22526	76264-101
A3A1P200	131-2790-00			CONN,HDR:PCB:RTANG,1 X 2,0.15 CTR,0.230 MLG X 0.120 TAIL,30 GOLD	80009	131-2790-00
A3A1P800	131-2790-00			CONN,HDR:PCB:RTANG,1 X 2,0.15 CTR,0.230 MLG X 0.120 TAIL,30 GOLD	80009	131-2790-00
A10	671-3637-00			CIRCUIT BD ASSY:CRT SOCKET BD	80009	671363700
A11	671-3761-00			CIRCUIT BD ASSY:SERIAL FILTER	80009	671376100
J1	131-0106-02			CONN,RF JACK:	80009	131-0106-02
J2	131-0106-02			CONN,RF JACK:	80009	131-0106-02
				ATTACHED PARTS		
	276-0569-00			CORE,EM,TOROID:FERRITE,UO=125,FREQ<5MHZ		
				END ATTACHED PARTS		
J3	196-3146-00			CA ASSY,SP:FLT FLEX:FLX,27 AWG,1.0 L,PCB,TERM,STR BOTH ENDS	15912	FSN-LA
J4	131-0106-02			CONN,RF JACK:	80009	131-0106-02
				ATTACHED PARTS		
	210-0255-00			TERM,LUG:0.391 ID,LKG,BRS CD PL	12327	ORDER BY DESCR
				END ATTACHED PARTS		
J5	131-0106-02			CONN,RF JACK:	80009	131-0106-02
				ATTACHED PARTS		
	276-0569-00			CORE,EM,TOROID:FERRITE,UO=125,FREQ<5MHZ		
				END ATTACHED PARTS		

1730-Series Replaceable Electrical Parts

Component Number	Tektronix Part Number	Serial / Assembly Number		Name & Description	Mfr. Code	Mfr. Part Number
		Effective	Discontinued			
J6	196-3146-00			CA ASSY,SP:FLT FLEX;FLX,27 AWG,1.0 L,PCB,TERM,STR BOTH ENDS	15912	FSN-LA
J7	131-0106-02			CONN,RF JACK:	80009	131-0106-02
J8	131-0106-02			CONN,RF JACK:	80009	131-0106-02
	276-0569-00			**ATTACHED PARTS** CORE,EM,TOROID:FERRITE,UO=125,FREQ<5MHZ **END ATTACHED PARTS**		
J9	196-3146-00			CA ASSY,SP:FLT FLEX;FLX,27 AWG,1.0 L,PCB,TERM,STR BOTH ENDS	15912	FSN-LA
J14	131-0106-02			CONN,RF JACK:	80009	131-0106-02
S1	260-2465-00			SW,PUSH:0.4A,125VAC,W/SLDR LUG,BTN W/YEL IDCTR	80009	260-2465-00
	174-2648-00			*ATTACHED PARTS* CA ASSY,SP: *END ATTACHED PARTS*	80009	174-2648-00
V1	154-0985-00			ELECTRON TUBE:CRT,FINISHED,D14-375GH/985 (1730 ONLY)	80009	154-0985-00
V1	154-0986-00			ELECTRON TUBE:CRT,FINISHED,D14-375GH/986 (1731 ONLY)	80009	154-0986-00
V1	154-0989-00			ELECTRON,TUBE:CRT,FINISHED,D14-375GH/989 (1735 ONLY)	80009	154-0989-00
V1	154-0985-16			ELECTRON,TUBE:CRT,FINISHED,D14-375WA/985 (1730 OPTION 74 ONLY)	80009	154-0985-16
V1	154-0986-16			ELECTRON,TUBE:CRT,FINISHED,D14-375WA/986 (1731 OPTION 74 ONLY)	80009	154-0986-16
V1	154-0989-16			ELECTRON,TUBE:CRT,FINISHED,D14-375WA/989 (1735 OPTION 74 ONLY) *ATTACHED PARTS*	80009	154-0989-16
	131-6014-00			CA ASSY,CRT:DISCRETE,ANODE LEAD:CRT,1,22 AWG,30KV,UL3239,58MM DIA A NODE X 1.9 L,0.125 *END ATTACHED PARTS*	20093	131-6014-00
W1	179-2997-01			WIRE HARNESS:DESCRETE, CRT ASSY:CPD,5,24AWG, 5,26 AWG,1X4,0.1CTR & 1X7,RCPT X 1X4 & 1X7,0.1 RCPT	80009	179299701
W3	174-3511-01			CA ASSY,SP:DESCRETE;CPD,4,26 AWG,8.0L,1X7,0.1CTR, RCPT X STRAIN RELIEF,PCB *ATTACHED PARTS*	9M860	174-3511-01
	343-0298-00			STRAP,RETAINING:0.25 DIA CABLE	85480	HCNY-250NA
	344-0111-00			INSUL,SPREADER:DEFL LEADS,POLYPROPYLENE *END ATTACHED PARTS*	TK1617	NA



Diagrams/Circuit Board Illustrations

Section 9

Diagrams/Circuit Board Illustrations

Symbols

Graphic symbols and class designation letters are based on ANSI Standard Y32.2–1975.

Logic symbology is based on ANSI Y32.14–1973 in terms of positive logic. Logic symbols depict the logic function performed and may differ from the manufacturer's data.

Overline, parenthesis, or leading slash indicate a low asserting state.

Example: $\overline{\text{ID CONTROL}}$, (ID CONTROL), or /ID CONTROL.

Abbreviations are based on ANSI Y1.1–1972.

Other ANSI standards that are used in the preparation of diagrams by Tektronix, Inc. are:

Y14.15, 1966 -- Drafting Practices.

Y14.2, 1973 -- Line Conventions and Lettering.

Y10.5, 1968 -- Letter Symbols for Quantities Used in Electrical Science and Electrical Engineering.

American National Standard Institute
1430 Broadway, New York, New York 10018

Component Values

Electrical components shown on the diagrams are in the following units unless noted otherwise:

Capacitors: Values one or greater are in picofarads (pF).

Values less than one are in microfarads (μF).

Resistors = Ohms (Ω).

The following information and special symbols may appear in this manual.

Assembly Numbers

Each assembly in the instrument is assigned an assembly number (e.g., A20). The assembly number appears on the diagram (in circuit board outline), circuit board illustration title, and lookup table for the schematic diagram.

The Replaceable Electrical Parts List is arranged by assembly number in numerical sequence; the components are listed by component number. Example:

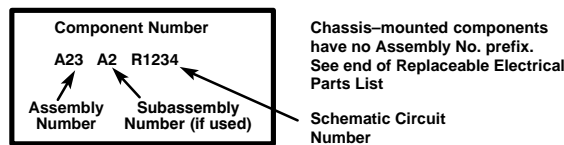

Grid Coordinates

The schematic diagram and circuit board component location illustration have grids. A lookup table with the grid coordinates is provided for ease of locating the component. Only the components illustrated on the facing diagram are listed in the lookup table.

When more than one schematic diagram is used to illustrate the circuitry on a circuit board, the circuit board illustration will only appear opposite the first diagram; the lookup table will list the diagram number of other diagrams that the other circuitry appears on.

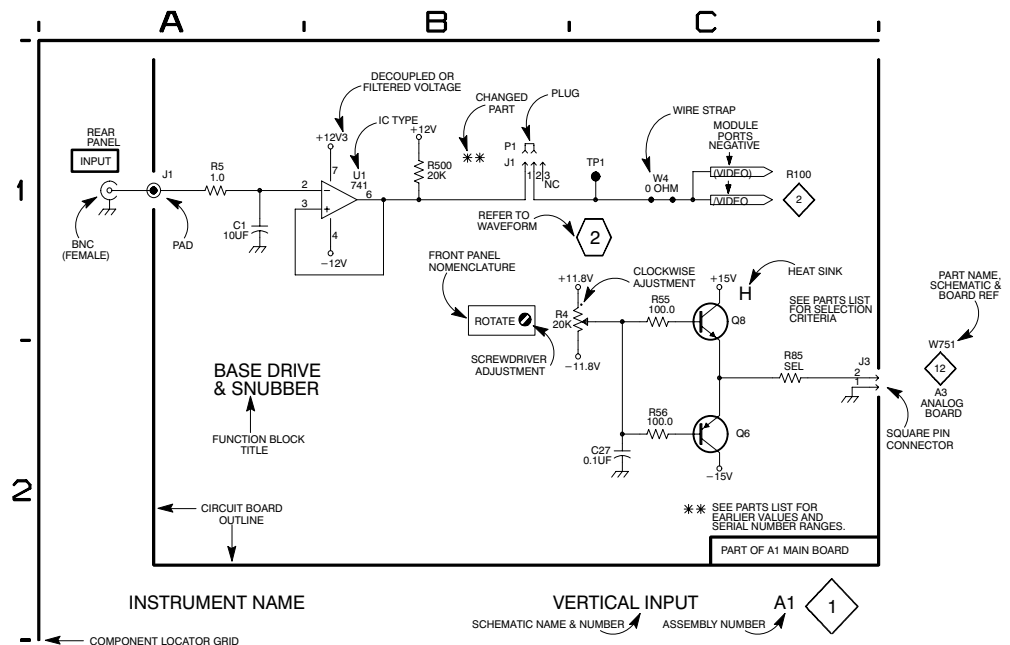

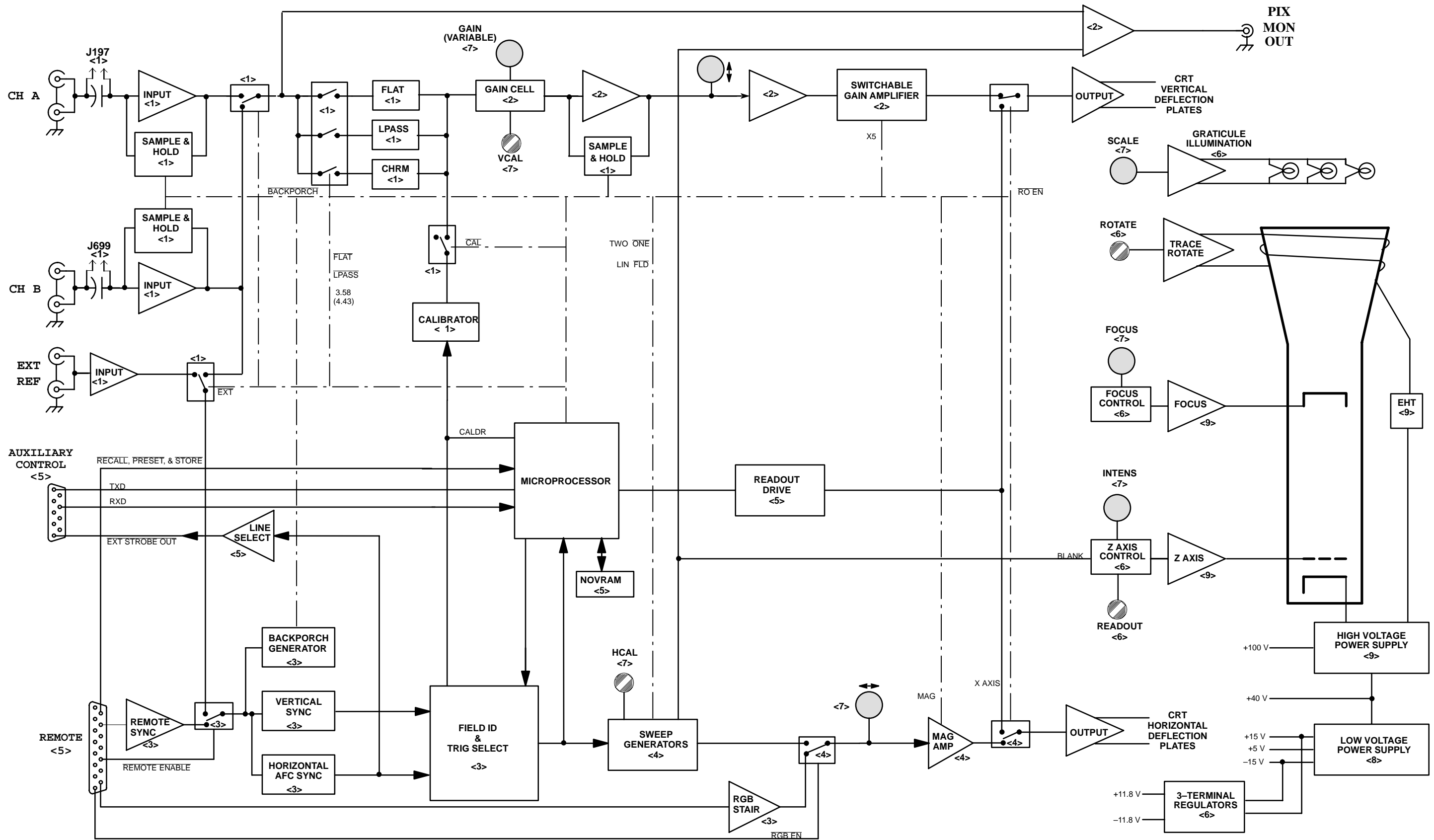

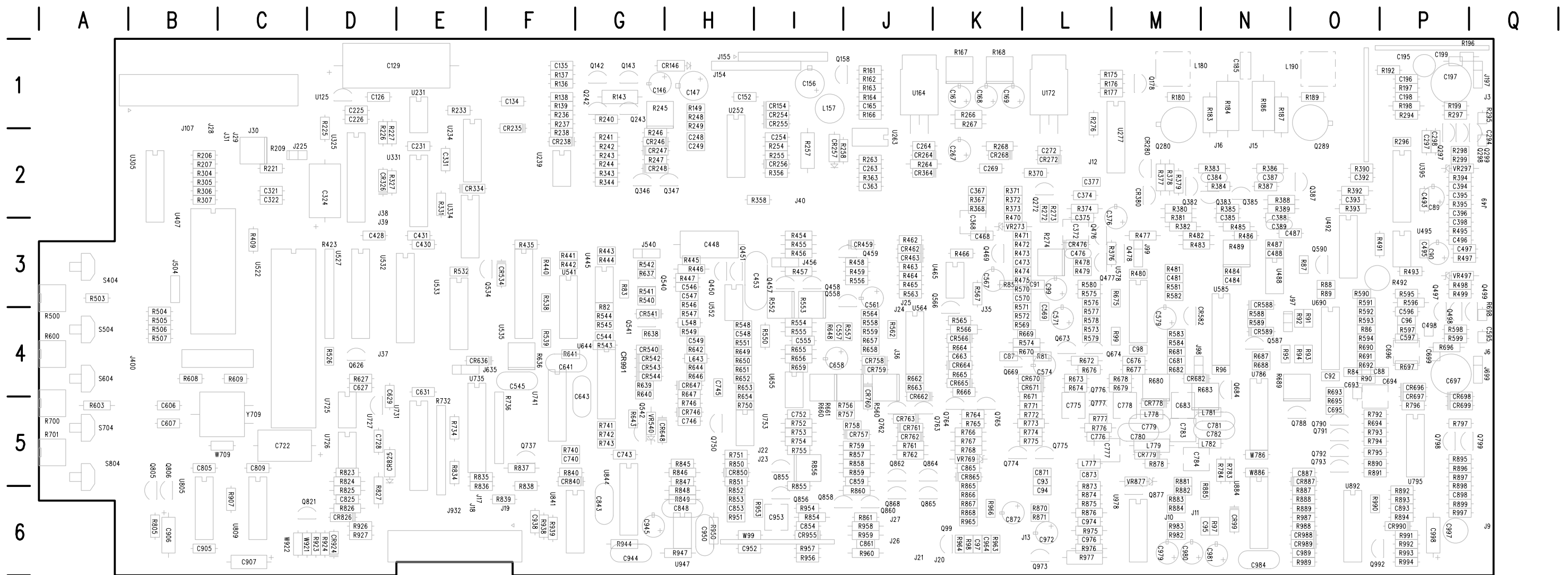

A3 Main Board

Static Sensitive Devices
See Maintenance Section

Schematic Diagram <1> Component Locator Chart

Assembly A3.

The schematic diagram has an alphanumeric grid to assist in locating parts within that diagram.

Comp No	Diag Loc	Bd Loc	Comp No	Diag Loc	Bd Loc	Comp No	Diag Loc	Bd Loc	Comp No	Diag Loc	Bd Loc	Comp No	Diag Loc	Bd Loc	Comp No	Diag Loc	Bd Loc	Comp No	Diag Loc	Bd Loc	Comp No	Diag Loc	Bd Loc			
C88	C2	O4	C392	D3	O2	C693	E1	O4	C871	G3	L5	CR698	E5	P5	J97	E2	O3	Q498	B4	P4	Q793	E1	O5	R96	E2	N4
C89	C1	P2	C393	D4	O2	C694	E1	P4	CR699	E5	P5	J98	E4	M4	Q499	B4	Q3	Q798	D4	P5	Q799	E5	Q5	R97	F4	N6
C90	C4	P3	C394	C3	P2	C695	F1	O5	CR778	H3	M5	J197	A1	Q1	Q587	E3	N4	Q992	F5	O6	R192	A2	P1	R196	A1	P1
C92	D1	O4							CR877	F4	O5	J699	A5	Q4	Q590	C3	O3									
C93	G3	L5	C395	B2	P2	C696	A4	P4	CR893	E4	P6	CR887	G4	O5	Q764	G3	K5	R84	C2	O4				R197	A2	P1
C94	G3	L6	C396	C1	P2	C697	A4	P4	CR898	C5	P6	CR988	F5	O6	Q765	G3	K5	R86	D2	O4				R198	B2	P1
C95	E4	N6	C398	B3	P3	C699	A4	P4	CR989	G5	O6	CR988	F5	O6	L778	H2	M5	R87	E2	O3				R199	B1	P1
C96	D2	P4	C487	D1	N3	C775	G3	L5	C997	C5	P6	CR990	F4	P6	L779	G2	M5	R88	E1	O3				R294	C3	P1
C195	A1	P1	C493	B2	P2	C776	G3	L5	C998	E5	P6				L781	G2	N5	Q774	H1	K5				R294	C3	P1
C196	A2	P1										L782	H1	N5	Q775	G1	L5	R89	E1	O3				R295	B1	Q1
			C495	B4	P3	C777	G3	L5	CR999	E4	N6	DS117	C1	A1				Q776	H2	L4						
C197	A1	P1	C496	B3	P3	C778	H2	M5	CR588	E3	N4	J3	A1	Q1	P197	A1		Q777	H2	L5	R90	D1	O4	R296	B3	P2
C198	B2	P1	C497	C3	P3	C779	G2	M5	CR589	E3	N4	J6	A4	Q4	P699	A5		Q778	H2	L5	R91	E2	O4	R297	B1	P1
C199	A1	P1	C498	C4	P4	C780	G2	M5	CR670	G1	L4	J9	A5	Q6				Q788	F1	O5	R92	E2	O4	R298	B1	P2
C294	C1	Q2	C595	B4	Q4	C781	G2	N5	CR671	G1	L4	J17	H5	E6							R93	E1	O4	R299	B1	P2
C297	B1	P2	C596	B4	P4	C782	G1	N5				J18	H5	E6	Q297	C1	P2	Q790	D1	O5	R94	E2	O4			
C298	C1	P2	C597	A4	P4	C783	G2	M5	CR696	E5	P4				Q298	B1	Q2	Q791	F1	O5						
C331	E3	E2	C683	H2	M5	C784	G2	M5	CR697	E4	P5	J49	A4	Q2	Q497	C4	P3	Q792	D1	O5	R95	D2	N4			

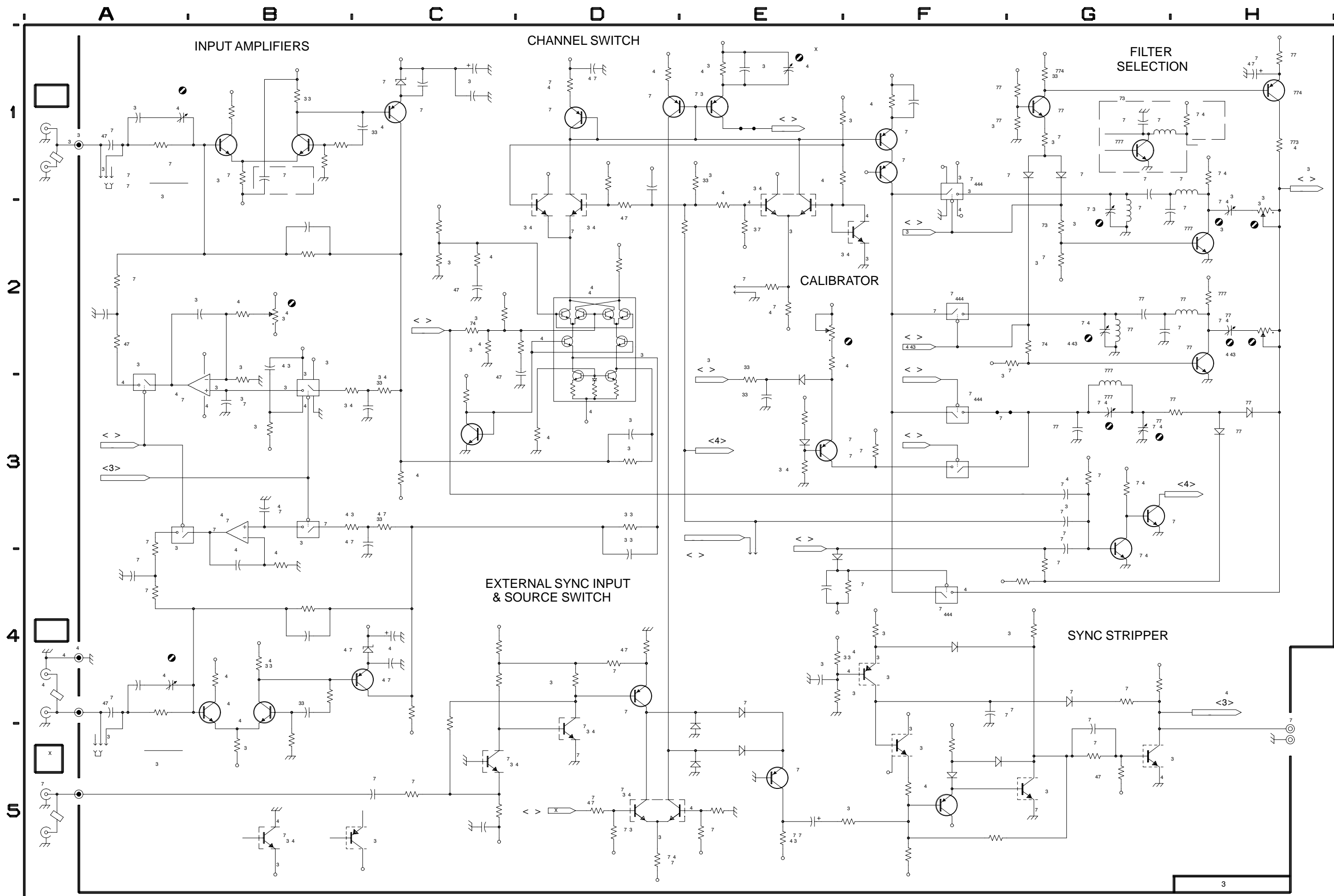

A3 Main Board Component Locator

(with cross-references to schematic diagrams 1, 2, 3, 4, 5, and 6).

Comp No	Diag No	Diag Loc	Bd Loc	Comp No	Diag No	Diag Loc	Bd Loc	Comp No	Diag No	Diag Loc	Bd Loc	Comp No	Diag No	Diag Loc	Bd Loc	Comp No	Diag No	Diag Loc	Bd Loc	Comp No	Diag No	Diag Loc	Bd Loc	Comp No	Diag No	Diag Loc	Bd Loc	Comp No	Diag No	Diag Loc	Bd Loc	Comp No	Diag No	Diag Loc	Bd Loc	Comp No	Diag No	Diag Loc	Bd Loc	Comp No	Diag No	Diag Loc	Bd Loc																																																																																																																																																																																																																																																																																																																																																																																																																																																																																																																																																																																																																																																																																																																																																																																																																																																																																																																																																																																																																																																																																																																																																																																																																																																																																																																																																																																																																																																																																																																																																																																																																																																																																																																																																																																																																																																					
C87	2	C3	K4	C468	2	E4	K3	C865	4	H2	K5	CR698	1	E5	P5	L777	1	G3	L5	Q799	1	E5	Q5	R241	6	C3	G2	R444	4	A2	G3	R565	4	F1	K4	R675	2	C2	M3	C88	1	C2	O4	C473	2	C5	K3	C871	1	G3	L5	CR699	1	E5	P5	L778	1	H2	M5	Q805	3	H3	B5	R242	6	E3	G2	R445	4	E3	H3	R566	4	F1	K4	R676	2	B5	L4	C89	1	C1	P2	C872	1	H1	K6	CR746	4	C3	H5	L779	1	G2	M5	Q806	3	G3	B5	R446	4	E2	H3	R567	4	F2	K3	R677	2	A3	M4	C90	1	C4	P3	C476	2	E3	L3	CR757	4	G3	J5	L781	1	G2	N5	R243	6	E3	G2	R447	4	E3	H3	R568	4	F3	K3	R678	1	G2	M4	C91	2	D3	L3	C481	2	B3	M3	CR758	4	B1	J4	L782	1	H1	N5	R244	6	C3	G2	R454	4	E3	I3	R569	2	D3	K4	C92	1	D1	O4	C484	2	C5	N3	C887	1	F4	O5	CR759	4	B1	J4	P99	2	C4	Q821	3	G2	C6	R245	6	C2	G1	R455	4	E2	I3	R570	2	D5	K3	C93	1	G3	L5	C487	1	D1	N3	C893	1	E4	P6	CR760	4	B1	J4	P197	1	A1	Q825	3	G1	I6	R246	6	E3	G2	R456	4	E4	I3	R571	2	C2	K4	C94	1	G4	L6	C488	2	B5	N3	C898	1	C5	P6	CR761	4	G3	J5	P456	4	E4	Q855	3	G1	I5	R247	6	E3	G2	R457	4	E4	I3	R572	2	C2	K4	C95	1	E4	N6	C493	1	B2	P2	CR762	4	G3	J5	P504	5	C3	Q856	3	G1	I6	R248	6	D2	H1	R458	4	E5	J3	R573	2	D2	L4	C96	1	D2	P4	C495	1	B4	P3	C907	3	H3	B6	P540	4	C5	Q858	4	G4	I6	R249	6	E3	H2	R459	4	E4	J3	R574	2	D2	K4	C97	3	C2	K6	C496	1	B3	P3	C908	3	G3	C6	P635	3	C4	Q862	4	G4	J5	R254	6	E1	I2	R462	4	E3	J3	R575	2	A2	L3	C98	2	C2	M4	C497	1	C3	P3	C938	3	C5	F6	P699	1	A5	Q864	4	H4	J5	R255	6	E2	I2	R463	4	F4	J3	R576	2	A2	L3	C99	2	C3	L3	C498	1	C4	P4	C944	3	A3	G6	CR778	1	H3	M5	Q865	4	H3	J6	R257	6	G3	I2	R464	4	E5	J3	R577	2	A2	L4	C126	5	E3	D1	C544	3	B2	G4	CR779	1	H3	M5	Q868	4	G3	J6	Q867	2	F1	M6	R258	6	F4	I2	R465	4	F2	J3	R578	2	B3	L4	C129	5	F3	D1	C545	3	B2	F4	CR825	5	E3	D5	Q873	2	G1	L6	Q869	1	A5	Q877	2	F1	M6	R259	6	G4	J2	R466	4	G1	K3	R579	2	C2	L4	C134	4	F4	F1	C546	4	D2	H3	CR826	3	H2	D6	Q99	3	C1	K6	Q878	2	F1	M6	R263	6	G4	J2	R470	2	E4	K3	R580	2	A3	L3	C135	6	G2	F1	C547	4	D2	H3	CR840	6	B2	F5	Q142	6	H2	G1	Q992	1	F5	O6	R266	6	E4	K1	R471	2	D4	K3	R581	2	B3	M3	C146	6	A4	G1	C548	4	D2	H4	CR850	3	F5	H5	Q143	6	H2	G1	R267	6	D5	K1	R472	2	D4	K3	R582	2	A2	M3	C147	5	F4	H1	C549	4	D4	H4	CR865	4	G3	K5	Q158	6	G4	I1	R81	2	C3	L4	R473	2	D4	K3	R583	2	B2	M4	C152	6	D2	H1	C554	4	F5	I4	CR887	1	G4	O5	Q178	2	F4	M1	R82	4	A3	G4	R474	2	D5	K3	R584	2	B1	M4	C156	6	G3	I1	C555	4	F5	I4	CR924	4	C3	D6	Q242	6	C2	G1	R83	4	A2	G3	R475	2	D3	K3	R585	1	E3	N4	C165	6	F4	J1	C557	4	F2	I4	CR924	4	C3	D6	Q243	6	B3	G1	R84	1	C2	O4	R476	2	D3	K3	R586	1	E3	N4	C167	6	F5	K1	C561	4	F5	J4	CR955	3	F1	I6	Q246	2	D4	L2	R85	2	D3	K3	R477	2	D4	L3	R587	1	E3	N4	C168	6	D5	K1	C567	4	F2	K3	CR988	1	F5	O6	Q272	2	D4	L2	R86	1	D2	O4	R478	2	D3	K3	R588	1	E3	N4	C169	6	D5	K1	C570	2	D5	K3	CR989	1	F5	O6	Q280	2	G3	M2	R87	1	E2	O3	R479	2	D3	K3	R589	1	E3	N4	C185	2	G2	N1	C571	2	A2	L4	CR990	1	F4	P6	Q289	2	G3	O2	R88	1	E1	O3	R480	2	B2	M3	R590	1	D3	O3	C195	1	A1	P1	C574	2	D2	L4	J3	1	A1	Q1	Q297	1	C1	P2	R89	1	E1	O3	R481	2	D1	M3	R591	1	C3	O3	C196	1	A2	P1	C575	2	C2	M4	J6	1	A4	Q4	Q298	1	B1	Q2	R90	1	D1	O4	R482	2	H3	M3	R592	1	D2	O4	C197	1	A1	P1	C595	1	B4	Q4	J9	1	A5	Q6	Q299	1	B1	Q2	R91	1	E2	O4	R483	2	H3	M3	R593	1	C2	O4	C198	1	B2	P1	C596	1	B4	P4	J10	2	H2	M6	Q346	6	D2	G2	R92	1	E2	O4	R484	2	H3	M3	R594	1	C2	O4	C199	1	A1	P1	C606	5	C3	B5	J11	2	H2	M6	Q347	6	D2	H2	R93	1	E2	O4	R485	2	G3	N3	R595	1	C4	P3	C225	5	E3	D1	C607	5	C4	B5	J12	3	D1	L2	Q382	2	G3	M2	R94	1	E2	O4	R486	2	C5	N3	R596	1	B4	P3	C226	5	E2	D1	C627	5	E4	D4	J15	2	H2	N2	Q383	2	G3	N2	R95	1	D2	N4	R487	2	G3	N3	R597	1	A3	P4	C231	5	E2	E2	C629	2	D4	D4	J16	2	H2	N2	Q385	2	H3	N2	R96	1	E2	N4	R488	2	B5	N3	R598	1	B5	P4	C248	6	E3	H2	C631	5	E3	E4	J17	1	H5	E6	Q387	2	G3	O2	R97	1	F4	N6	R489	2	H3	N3	R599	1	B5	P4	C249	6	E3	H2	C641	4	C2	F4	J18	1	H5	E6	Q450	4	E4	H3	R98	3	C1	K6	R600	4	D2	A4	C254	6	F1	I2	C643	3	B2	G5	Q451	4	E2	H3	R99	2	C2	M6	R603	2	A1	A5	C263	6	F4	J2	C658	4	C1	I4	J19	3	E1	F6	Q454	4	E5	I3	R136	6	G2	F1	R608	5	C3	B4	C264	6	E5	J2	C663	4	F2	K4	J20	3	C1	K6	Q457	4	E5	I3	R137	6	G2	F1	R609	5	C3	C4	C267	6	F5	K2	C676	2	B5	M4	J21	3	C1	J6	Q458	4	E3	I3	R138	6	C4	F1	R627	2	C4	D4	C269	2	F4	K2	C681	2	B1	M4	J22	3	H1	I5	Q459	4	E5	J3	R139	6	C2	F1	R640	4	D5	G5	C272	6	D5	L2	C683	1	H2	M5	J23	3	H1	I5	Q469	2	E4	K3	R143	6	H2	G1	R500	6	D3	A4	C294	1	C1	P2	C693	1	E1	O4	J24	4	D1	J4	Q476	2	E3	L3	R503	6	D3	A3	C297	1	B1	Q2	C694	1	E1	P4	J25	4	D1	J3	Q477	2	E3	L3	R504	5	H4	B4	C298	1	C1	P2	C695	1	F1	O5	J26	4	H3	J6	Q478	2	D3	M3	R505	5	H4	B4	C321	5	F2	C2	C696	1	A4	P4	J27	4	H3	J6	Q497	1	C4	P3	R327	4	C2	D2	R506	5	H4	B4	C322	5	F2	C2	C697	1	A4	P4	J28	4	H1	B1	Q498	1	B4	P4	R331	1	E3	E2	R641	4	C2	F4	C324	5	C4	D2	C699	1	A4	P4	J29	4	H1	C2	Q499	1	B4	Q3	R334	6	B3	G2	R642	4	D4	H4	C331	1	E3	E2	C722	5	E4	C5	J30	4	H1	C2	Q534	4	B5	F3	R337	2	E4	K2	R643	4	D4	G5	C363	6	G3	J2	C728	5	E3	D5	J31	4	H1	C2	Q540	4	C5	G3	R370	2	C5	L2	R644	4	D4	H4	C367	2	D4	K2	C740	4	C3	F5	J32	4	H3	J6	Q541	4	D4	G4	R371	2	C3	K2	R645	4	D4	H4	C368	2	E4	K2	C743	3	F1	G5	J33	4	B3	D2	Q542	4	D4	G5	R372	2	E4	K2	R646	4	D2	H4	C372	2	E4	L3	C745	3	C2	H4	J34	4	B3	D2	Q554	4	F5	I3	R373	2	E4	K2	R647	3	C2	H5	C374	2	C4	L2	C746	3	C2	H5	J35	4	H2	K4	Q556	4	F1	K3	R374	2	F3	M2	R648	4	F5	I4	C375	2	E3	L3	C752	4	C1	I5	J36	4	D1	J4	Q557	1	E3	N4	R375	2	F3	M2	R649	4	D3	H4	C385	2	G3	N3	C775	1	G3	L5	J37	4	D1	D4	Q590	1	C3	O3	R376	2	D3	L3	R650	4	D3	H4	C387	2	H3	N2	C777	1	G3	L5	J38	4	B3	D2	Q626	5	D4	D4	R381	2	E3	M3	R651	4	C3	H4	C388	2	H4	N3	C781	1	G2	N5	J39	4	B3	D3	Q669	2	C2	K4	R382	2	G3	M3	R652	4	D4	H4	C389	2	G3	N3	C782	1	G1	N5	J40	4	D5	I2	Q673	2	C2	L4	R383	2	G3	N2	R653	4	D4	H4	C392	1	D3	O2	C783	1	G2	M5	J49	1	A4	Q2	Q674	2	C2	L4	R384	2	G3	N2	R654	4	D3	H5	C393	1	D4	O2	C784	1	G2	M5	J97	1	E2	O3	Q684	2	A3	N4	R385	2	G3	N2	R655	4	F5	I4	C394	1	C3	P2	C805	5	F3	B5	J98	1	E4	M4	Q737	3	B1	F5	R386	2	H3	N2	R656	4	F5	I4	C395	1	C3	P2	C809	5	F3	C5	J99	2	C4	M3	Q750	4	D3	H5	R387	2	H3	N2	R657	4	E1	J4	C396	1	B2	P2	C825	5	F4	D6	J107	5	A3	B2	Q762	4	F3	J5	R388	2	H3	N2	R658	4	C1	J4	C398	1	B3	P3	C843	3	A2	G6	J109	2	A3	B2	Q763	4	G4	K5	R389	2	H3	N2	R659	4	C1	I4	C428	5	E3	D3	C848	3	B1	H6	J115	6	A5	H1	Q774	1	H1	K5	R390	1	B3	O2	R660	4	F3	I5	C430	5	E3	E3	C853	3	E5	H6	J117	6	A4	H1	Q775	1	G1	L5	R391	1	B3	O2	R661	4	F3	I5	C431	4	C2	E3	C

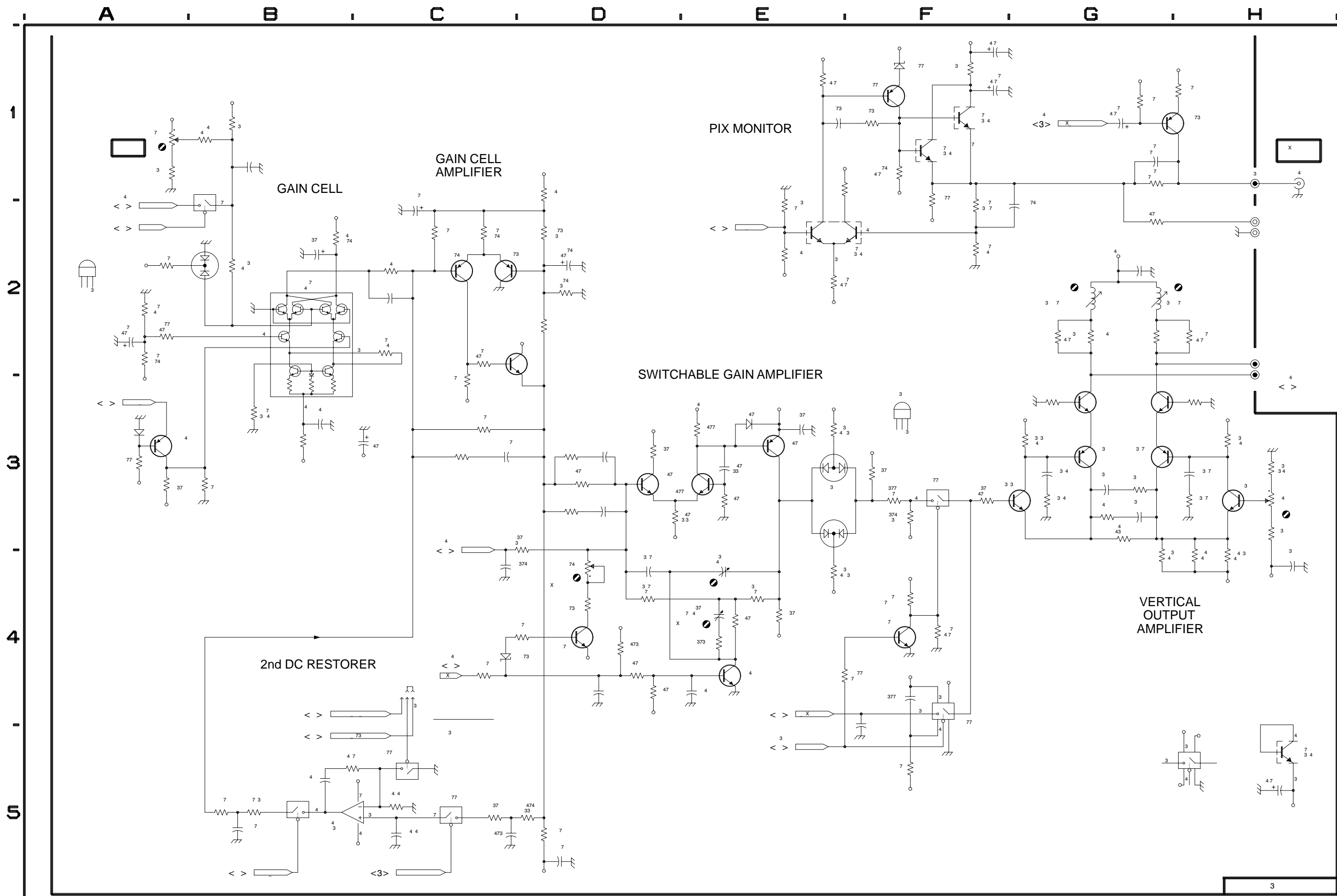

Schematic Diagram <3> Component Locator Chart

The schematic diagram has an alphanumeric grid to assist in locating parts within that diagram.

Assembly A3. Partial Assembly A3 also shown on Diagrams 1, 2, 4, 5, and 6.

Comp No	Diag Loc	Bd Loc	Comp No	Diag Loc	Bd Loc	Comp No	Diag Loc	Bd Loc	Comp No	Diag Loc	Bd Loc
C97	C2	K6	J19	E1	F6	R755	G2	I5	R939	F1	F6
C544	B2	G4	J20	C1	K6	R805	G3	B6	R944	A3	G6
C545	B2	F4	J21	C1	J6				R947	D5	H6
C643	B2	G5	J22	H1	I5	R834	C3	E5	R950	C2	H6
C743	F1	G5	J23	H1	I5	R835	C5	E5	R951	E5	H6
C745	C2	H4	J635	C4	E4	R836	C5	E6	R953	F1	I6
						R837	A1	F5			
C746	C2	H5	P635	C4		R838	A1	F6	R954	G1	I6
C843	A2	G6							R956	F1	I6
C848	B1	H6	Q99	C1	K6	R839	C5	F6	R957	F1	I6
C853	E5	H6	Q737	B1	F5	R840	B2	F5	R963	B1	K6
C854	G1	I6	Q805	H3	B5	R845	F5	H5	R964	C2	K6
C906	H3	B6	Q806	G3	B5	R846	F5	H5			
C907	G3	C6	Q821	G2	C6	R847	C2	H5	U535	G3	F4
C938	C5	F6	Q855	G1	I5				U644	B2	G4
			Q856	G1	I6	R848	C2	H6	U735	D4	E4
C944	A3	G6				R849	B1	H6	U753B	F5	I5
C945	E5	G6	R98	C1	K6	R850	D5	H5	U841A	C4	F6
C950	E5	H6	R435	H3	F3	R851	E5	H5			
C952	F2	H6	R538	G3	F3	R852	E5	H6	U841B	C5	F6
C953	F1	I6	R539	G3	F4				U841C	F1	F6
C964	C1	K6	R543	B2	G4	R853	E5	H6	U841D	D2	F6
						R854	G1	I6	U844A	B1	G5
CR636	F5	E4	R636	B2	F4	R855	G1	I6	U844B	A3	G5
CR647	C2	H4	R647	C2	H5	R856	G1	I5	U947A	E5	H6
CR648	C3	G5	R734	C3	E5	R907	G3	C6	U947B	C2	H6
CR826	H2	D6	R736	D3	F5						
CR850	F5	H5	R741	C2	G5	R923	G2	D6	W20	C1	
CR955	F1	I6				R924	G2	D6	W99	F1	H6
CR991	D2	G4	R742	B3	G5	R926	G2	D6	W921	G2	C6
			R743	B3	G5	R938	E1	F6			
J12	D1	L2	R751	D5	H5						

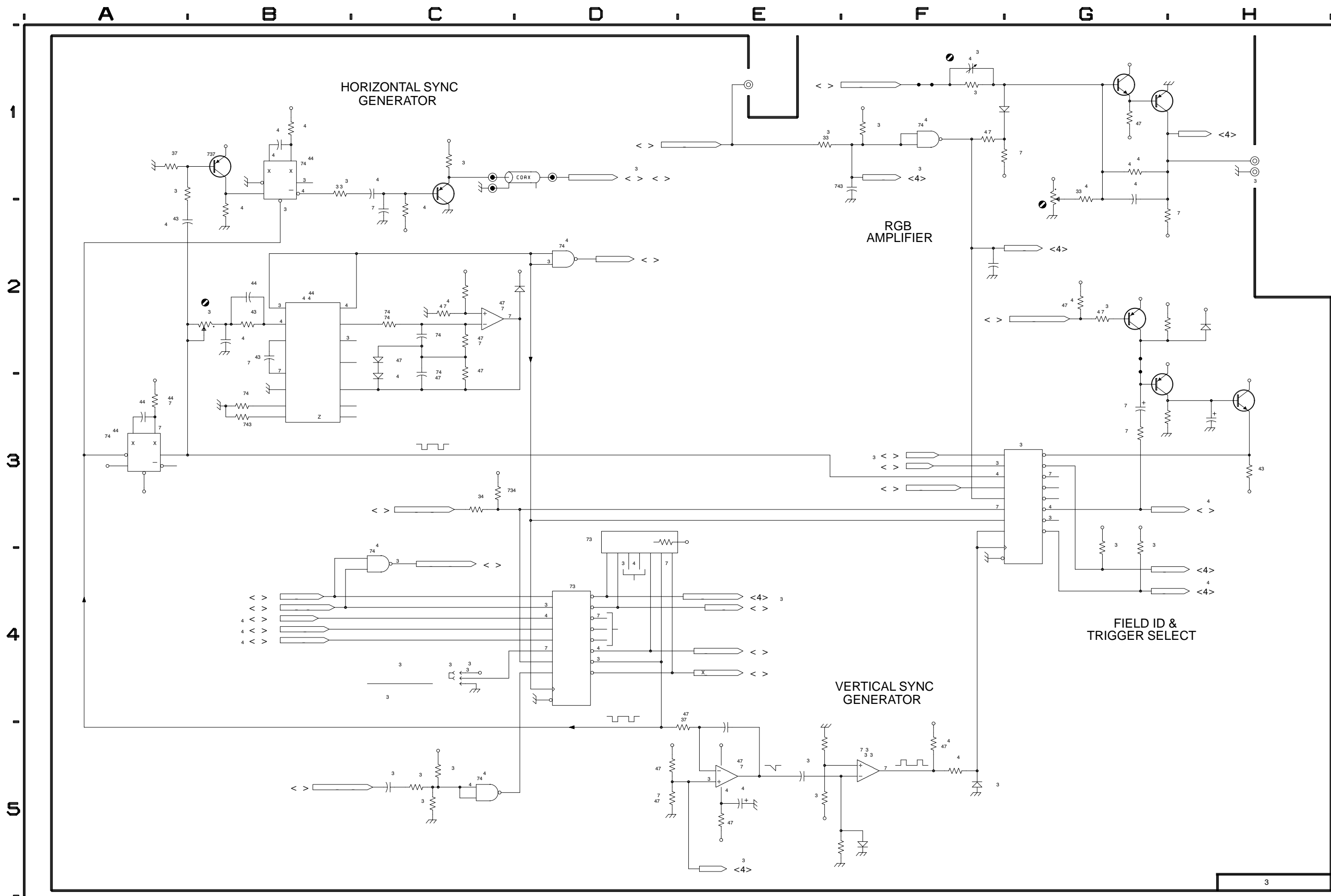

Schematic Diagram <4> Component Locator Chart

The schematic diagram has an alphanumeric grid to assist in locating parts within that diagram.

Assembly A3. Partial Assembly A3 also shown on Diagrams 1, 2, 3, 5, and 6.

Comp No	Diag Loc	Bd Loc	Comp No	Diag Loc	Bd Loc	Comp No	Diag Loc	Bd Loc	Comp No	Diag Loc	Bd Loc
C134	F4	F1	J37	D1	D4	R541	C4	G3	R746	D3	H5
C431	C2	E3	J38	B3	D2	R542	C5	G3	R750	D3	H5
C448	E3	H3	J39	B3	D3	R544	A3	G4	R752	C1	I5
C453	E2	I3	J40	D5	I2	R545	A2	G4	R753	B1	I5
C546	D2	H3	J456	E4	I3	R546	D2	H4	R754	B1	I5
			J540	C5	G3	R547	C2	H4	R756	F3	I5
C547	D2	H3									
C548	D2	H4	L548	C2	H4	R548	D2	H4	R757	F3	I5
C549	D4	H4	L643	C4	H4	R549	D2	H4	R758	G4	J5
C555	F5	I4				R550	E2	I4	R759	G4	J5
C557	F2	I4	P456	E4		R551	D2	H4	R761	G4	J5
			P540	C5		R552	E3	I3	R762	H4	J5
C561	F5	J4									
C567	F2	K3	Q450	E4	H3	R553	F3	I3	R766	G3	K5
C641	C2	F4	Q451	E2	H3	R554	E3	I4	R767	F4	K5
C658	C1	I4	Q457	E5	I3	R555	F3	I4	R768	G4	K5
C663	F2	K4	Q458	E3	I3	R556	E3	J3	R857	H4	J5
			Q459	E5	J3	R557	F2	J4	R858	G4	J5
C740	C3	F5									
C752	C1	I5	Q534	B5	F3	R558	E2	J4	R859	H4	J5
C859	H4	J5	Q540	C5	G3	R559	E2	J4	R860	H4	J6
C861	G3	J6	Q541	D4	G4	R560	A1	J5	R861	G3	J6
C865	H2	K5	Q542	D4	G5	R562	E1	J4	R865	G2	K6
			Q558	F5	I3	R563	F2	J3	R866	G3	K6
CR326	C2	D2									
CR334	D2	E2	Q566	F1	K3	R564	F2	J4	R867	H3	K6
CR459	E5	J3	Q750	D3	H5	R565	F1	K4	R868	H2	K6
CR462	F5	J3	Q762	F3	J5	R566	F1	K4	R958	H3	J6
CR463	E3	J3	Q763	G4	K5	R567	F2	K3	R959	G3	J6
			Q858	G4	I6	R600	D2	A4	R960	G3	J6
									R965	H3	K6
CR534	E5	F3							R966	G3	K6
CR540	D5	G4	Q860	H4	J6	R637	C4	G3			
CR541	C5	G4	Q862	G4	J5	R638	D5	G4			
CR542	D5	G4	Q864	H4	J5	R639	D5	G4	U234A	A4	E1
CR543	D4	G4	Q865	H3	J6	R640	D5	G5	U234B	C5	E1
			Q868	G3	J6	R641	C2	F4	U234C	G1	E1
CR544	D4	G4							U334A	B4	E2
CR566	F1	K4	R82	A3	G4	R642	D4	H4	U334B	C3	E2
CR662	F5	J5	R83	A2	G3	R643	D4	G5			
CR664	F2	K4	R327	C2	D2	R644	D4	H4	U334C	B2	E2
CR665	F4	K4	R440	B5	F3	R646	D2	H4	U445A	A3	G3
			R441	B3	F3	R648	F5	I4	U445B	A2	G3
CR746	C3	H5							U465A	G1	K3
CR757	G3	J5	R442	B2	F3	R649	D3	H4	U465B	G1	K3
CR758	B1	J4	R443	A3	G3	R650	D3	H4			
CR759	B1	J4	R444	A2	G3	R651	C3	H4	U541A	B2	F3
CR760	B1	J4	R445	E3	H3	R652	D4	H4	U541B	B4	F3
			R446	E2	H3	R653	D2	H4	U552A	E3	H3
CR761	G3	J5							U552B	E2	H3
CR762	G3	J5	R447	E3	H3	R654	D3	H5	U564A	F5	J4
CR763	A1	J5	R454	E3	I3	R655	F5	I4			
CR865	G3	K5	R455	E2	I3	R656	F5	I4	U564B	F4	J4
CR924	C3	D6	R456	E4	I3	R657	E1	J4	U564C	F2	J4
			R457	E4	I3	R658	C1	J4	U564D	F2	J4
J24	D1	J4							U655A	F5	I4
J25	D1	J3	R458	E5	J3	R659	C1	I4	U655B	C1	I4
J26	H3	J6	R459	E4	J3	R660	F3	I5			
J27	H3	J6	R462	E3	J3	R661	F3	I5	U741A	C2	F4
J28	H1	B1	R463	F4	J3	R662	F3	J4	U741B	B3	F4
			R464	E5	J3	R663	A1	J4	U753A	D3	I5
J29	H1	C2									
J30	H1	C2	R465	F2	J3	R664	F1	K4	VR540	D4	G5
J31	H1	C2	R466	G1	K3	R665	F4	K4	VR769	G2	K5
J35	H2	K4	R532	A5	E3	R666	F3	K4			
J36	D1	J4	R540	C5	G3	R740	C3	F5			

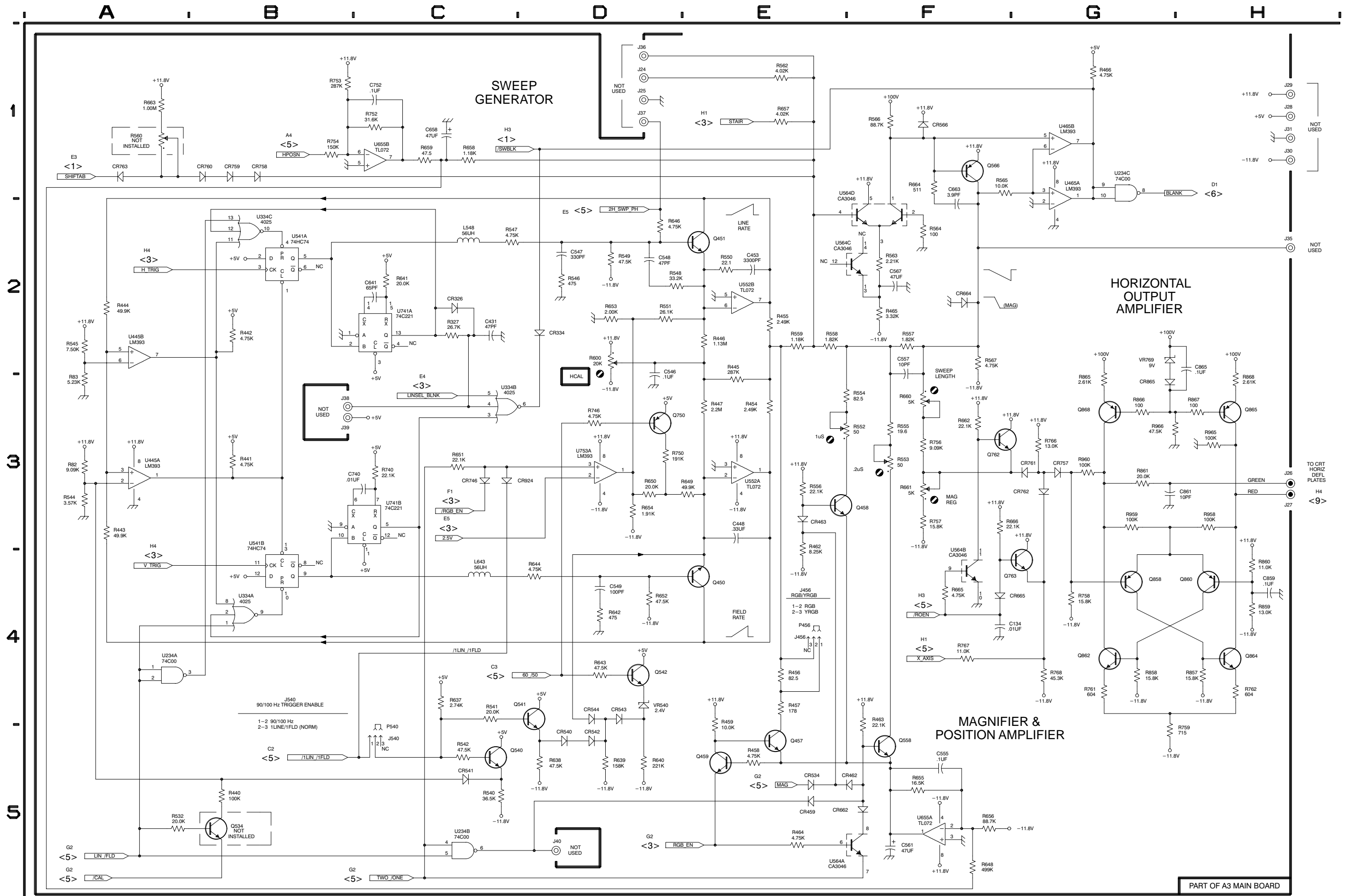

PART OF A3 MAIN BOARD

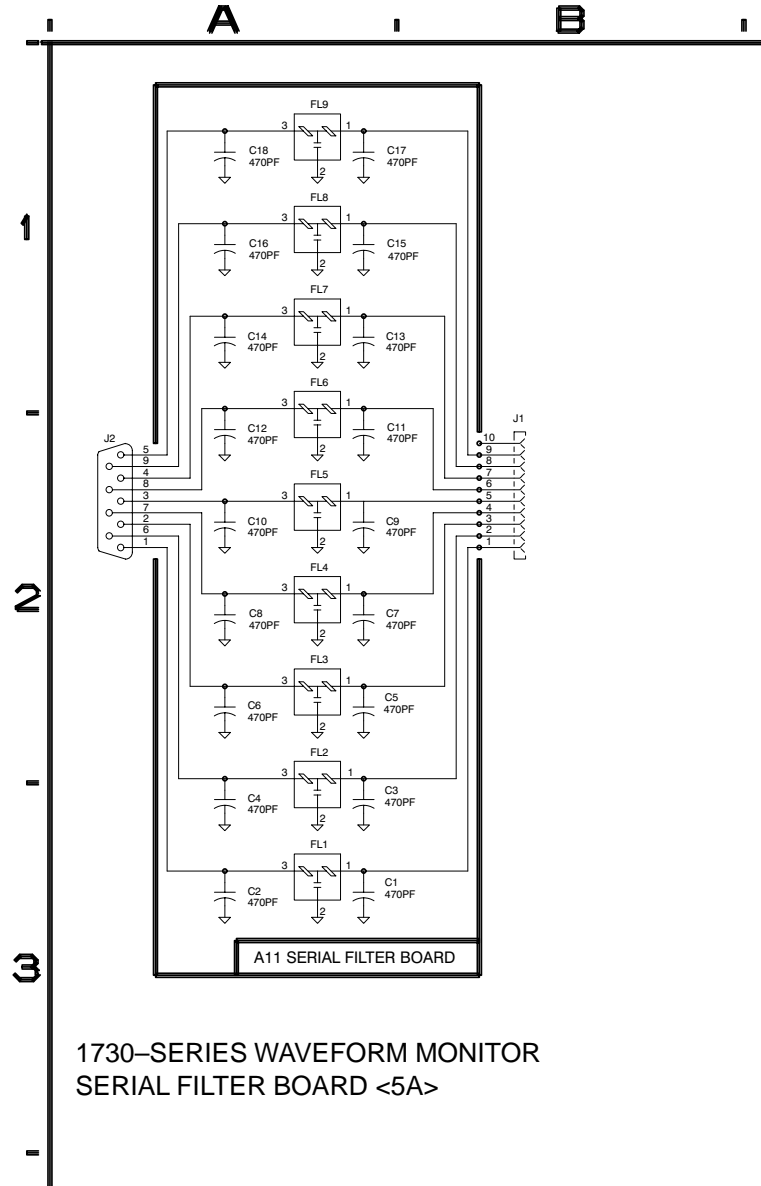

1730-SERIES WAVEFORM MONITOR
SERIAL FILTER BOARD <5A>

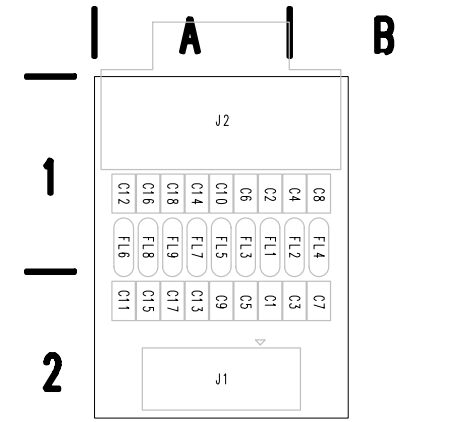

A11 Serial Filter Board

⊗ **Static Sensitive Devices**
See Maintenance Section

Schematic Diagram <5> & <5A> Component Locator Chart

The schematic diagram has an alphanumeric grid to assist in locating parts within that diagram.

Assembly A3. Partial Assembly A3 also shown on Diagrams 1, 2, 3, 4, and 6.

Comp No	Diag Loc	Bd Loc	Comp No	Diag Loc	Bd Loc	Comp No	Diag Loc	Bd Loc	Comp No	Diag Loc	Bd Loc
A3			R209	G2	C2				A11		
			R221	C4	C2	U234D	G3	E1	Located on diagram 5A		
C126	E3	D1	R225	G2	D1	U305A	G5	B2	C1	A3	A2
C129	F3	D1	R226	H1	D1	U305B	H4	B2	C2	A3	B1
C147	F4	H1				U305C	H4	B2	C3	A3	B2
C225	E3	D1	R227	H1	D1	U305D	H4	B2	C4	A3	B1
C226	E2	D1	R233	H1	E1				C5	A2	A2
			R304	G4	B2	U305E	H5	B2			
C231	E2	E2	R305	G4	B2	U325	G1	D2	C6	A2	A1
C321	F2	C2	R306	G4	B2	U331A	G3	D2	C7	A2	B2
C322	F2	C2				U331B	G3	D2	C8	A2	B1
C324	C4	D2	R307	G4	B2	U407	G4	B2	C9	A2	A2
C428	E3	D3	R409	F3	C3				C10	A2	A1
			R423	D2	D3	U522	C3	C3			
C430	E3	E3	R504	H4	B4	U527	E1	D3	C11	A2	A2
C606	C3	B5	R505	H4	B4	U532	G2	D3	C12	A2	A1
C607	C4	B5				U533	E2	E3	C13	A1	A2
C627	E4	D4	R506	H4	B4	U725	D4	D5	C14	A1	A1
C631	E3	E4	R507	H5	B4				C15	A1	A2
			R526	C3	D4	U726	E4	D5			
C722	E4	C5	R608	C3	B4	U727	E3	D5	C16	A1	A1
C728	E3	D5	R609	C3	C4	U731	D1	D5	C17	A1	A2
C805	F3	B5	R732	C1	E5	U805A	E1	B5	C18	A1	A1
C809	F3	C5	R823	E4	D5	U805B	E5	B5			
C825	F4	D6	R824	F4	D5				FL1	A3	A1
C905	E5	B6	R825	E4	D6	U805C	D5	B5	FL2	A3	B1
C984	E5	N6	R826	F4	D6	U805D	D5	B5	FL3	A2	A1
						U809A	B3	C6	FL4	A2	B1
CR146	F3	G1	R827	F4	D6	U809B	D5	C6	FL5	A2	A1
CR825	E3	D5	R927	B2	D6	U809C	D5	C6			
									FL6	A2	A1
J107	A3	B2	S404	B5	A3	U809D	B2	C6	FL7	A1	A1
J504	C3	B3	S504	B4	A4	U884	E5	N5	FL8	A1	A1
J932	A1	E6	S604	B4	A4				FL9	A1	A1
			S704	B4	A5	W709	B3	B5			
P504	C3		S804	B4	A5	W922	B2	C6	J1	B2	A2
									J2	A2	A1
Q626	D4	D4	U125	E3	D1	Y709	C3	C5			
			U231A	G1	E1						
R206	G4	B2	U231B	G1	E1						
R207	G4	B2									

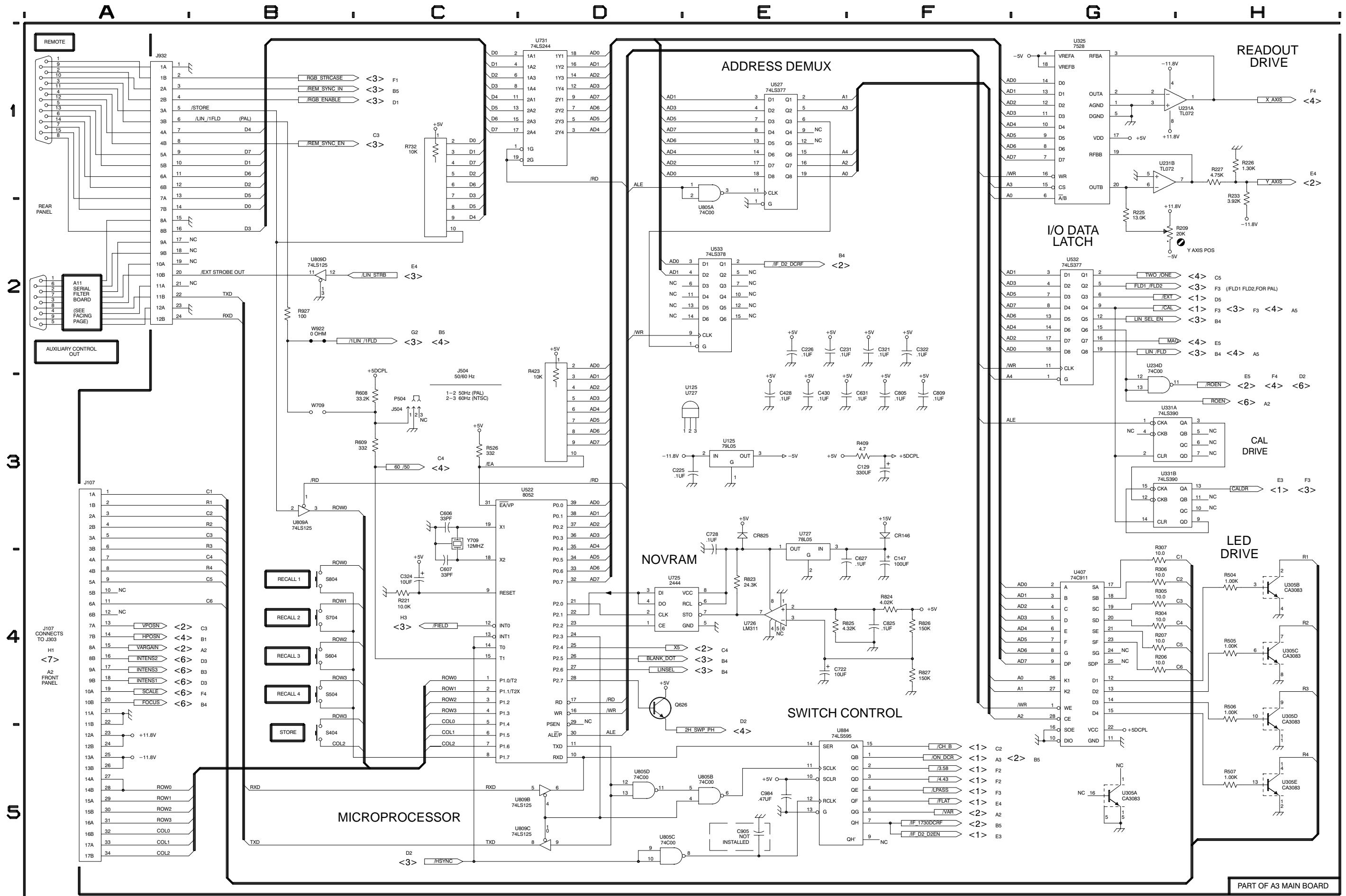

Schematic Diagram <6> Component Locator Chart

The schematic diagram has an alphanumeric grid to assist in locating parts within that diagram.

Assembly A3. Partial Assembly A3 also shown on Diagrams 1, 2, 3, 4, and 5.

Comp No	Diag Loc	Bd Loc	Comp No	Diag Loc	Bd Loc	Comp No	Diag Loc	Bd Loc
C135	G2	F1	J400	G3	B4	R246	E3	G2
C146	A4	G1				R247	E3	G2
C152	D2	H1	L157	G3	I1			
C156	G3	I1				R248	D2	H1
C165	F4	J1	Q142	H2	G1	R249	E3	H2
			Q143	H2	G1	R254	E1	I2
C167	F5	K1	Q158	G4	I1	R255	E2	I2
C168	D5	K1				R257	G3	I2
C169	D5	K1	Q242	C2	G1			
C248	E3	H2	Q243	B3	G1	R258	F4	I2
C249	E3	H2	Q346	D2	G2	R263	G4	J2
			Q347	D2	H2	R264	F5	J2
C254	E1	I2				R266	E4	K1
C263	F4	J2	R136	G2	F1	R267	D5	K1
C264	E5	J2	R137	G2	F1			
C267	F5	K2				R268	D5	K2
C272	D5	L2	R138	C4	F1	R343	B3	G2
C363	G3	J2	R139	C2	F1	R344	B3	G2
			R143	H2	G1	R356	D1	I2
CR154	D1	I1	R149	D1	H1	R358	E2	H2
CR235	B2	F2	R161	F3	J1			
CR238	B3	F2				R363	F4	J2
CR246	E3	G2	R162	F3	J1	R500	D3	A4
			R163	F3	J1	R503	D3	A3
CR247	E2	G2	R164	F3	J1	R701	G2	A5
CR248	D2	G2	R166	F4	J1			
CR254	D2	I1	R167	E5	K1	U164	E5	J1
CR255	D1	I1				U172	D5	L1
CR256	D1	I2	R168	D5	K1	U239A	B3	F2
			R236	C2	F1	U239B	B2	F2
CR257	G4	I2	R237	B2	F1	U252A	E2	H1
CR264	F5	J2	R238	B3	F2	U252B	E2	H1
CR268	D5	K2	R240	B2	G1			
CR272	D4	L2				U252C	E3	H1
CR364	F5	J2	R241	C3	G2	U252D	D2	H1
CR840	B2	F5	R242	E3	G2	U263A	F3	J2
			R243	E3	G2	U263B	F4	J2
J154	A4	H1	R244	C3	G2			
J155	A5	H1	R245	C2	G1			
J225	H2	C2						

A B C D E F G H

1

2

3

4

5

FOCUS CONTROL

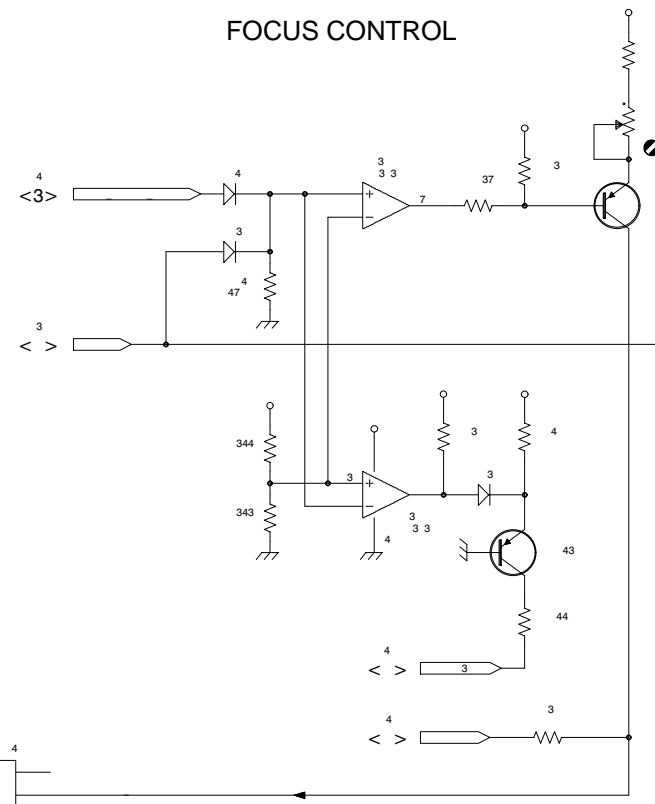

Z AXIS CONTROL

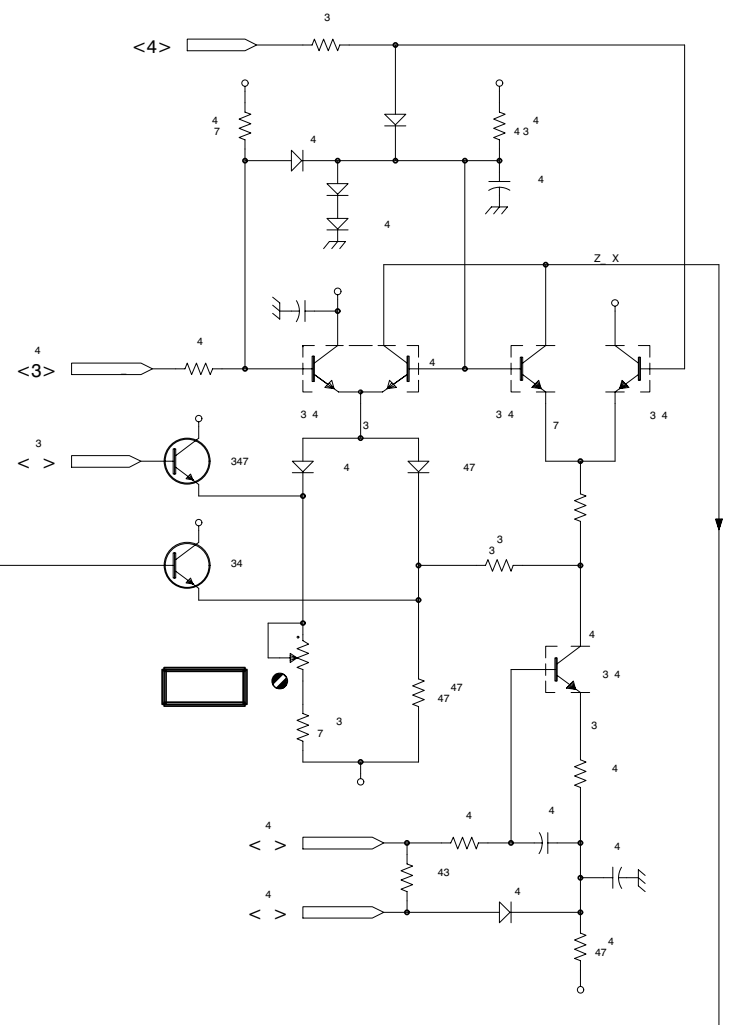

TRACE ROTATION

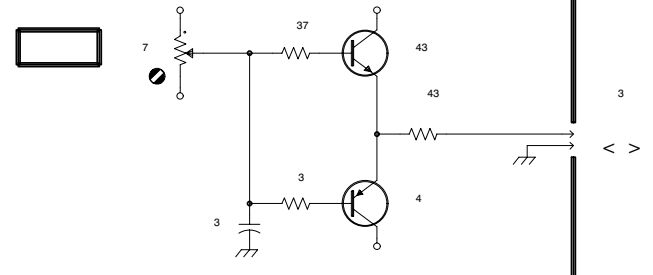

GRATICULE ILLUMINATION

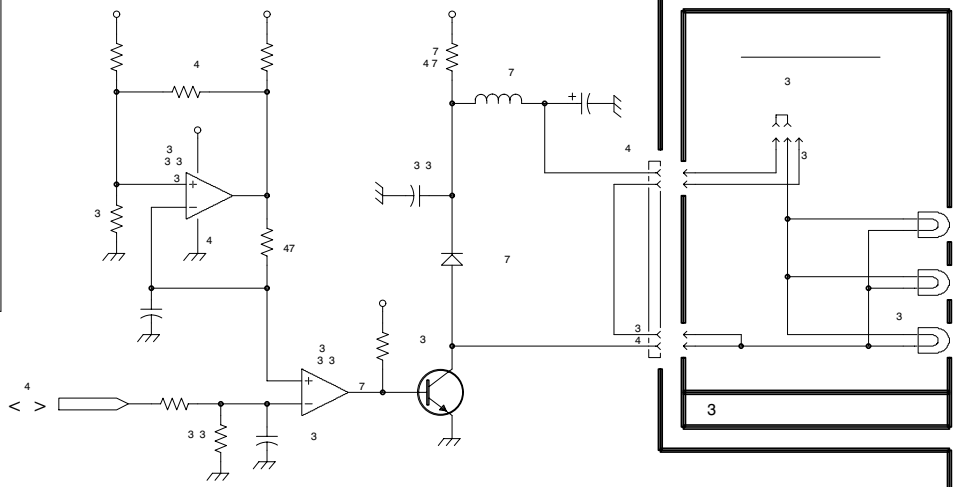

± 11.8V REGULATORS

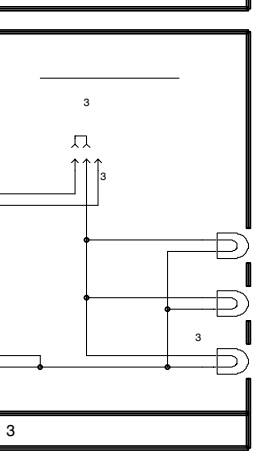
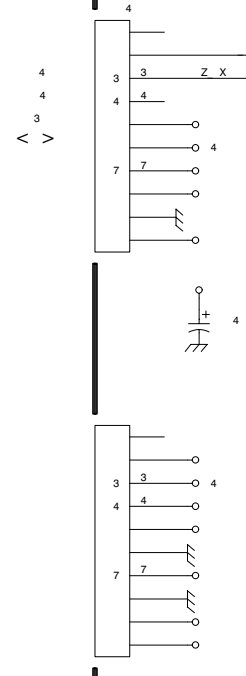
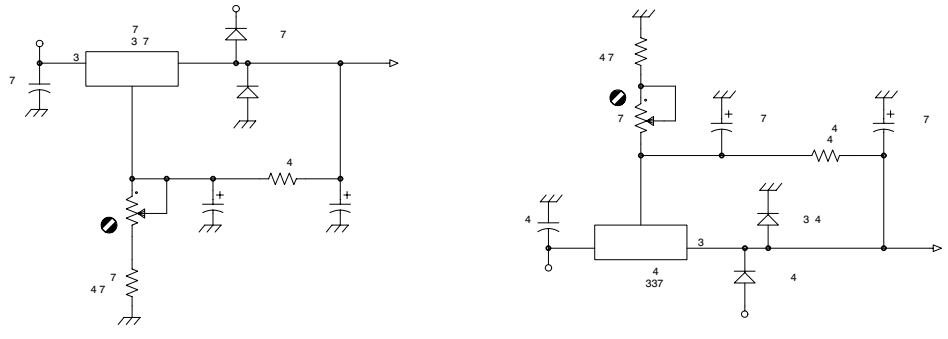

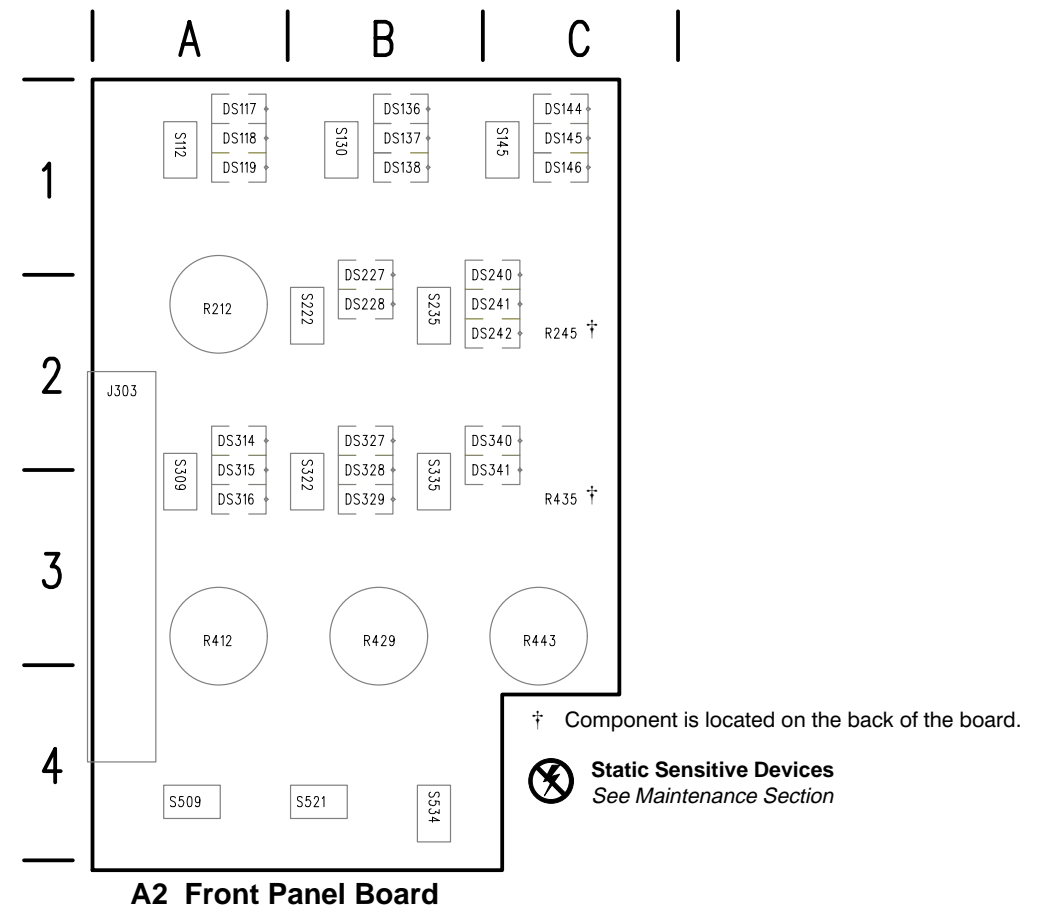

Schematic Diagram <7> Component Locator Chart

The schematic diagram has an alphanumeric grid to assist in locating parts within that diagram.

Assembly A2.

Comp No	Diag Loc	Bd Loc	Comp No	Diag Loc	Bd Loc	Comp No	Diag Loc	Bd Loc
DS117	C1	A1	DS314	C4	A2	R435	F2	C3
DS118	C2	A1	DS315	C5	A3	R443	F2	C3
DS119	C2	A1	DS316	C5	A3			
DS136	C1	B1	DS327	C4	B2	S112	F3	A1
DS137	C2	B1	DS328	C5	B3	S130	F3	B1
						S145	F3	C1
DS138	C2	B1	DS329	C5	B3	S222	F4	B2
DS144	D1	C1	DS340	D4	B2	S235	F4	B2
DS145	D2	C1	DS341	D5	B3			
DS146	D2	C1				S309	F4	A2
DS227	C3	B2	J303	H1	A2	S322	F4	B2
						S335	F4	B2
DS228	C3	B2	R212	F2	A2	S509	F5	A4
DS240	C3	B2	R245	F1	C2	S521	F5	B4
DS241	C3	B2	R412	F3	A3	S534	F5	B4
DS242	C4	B2	R429	F2	B3			

A B C D E F G H

1
2
3
4
5

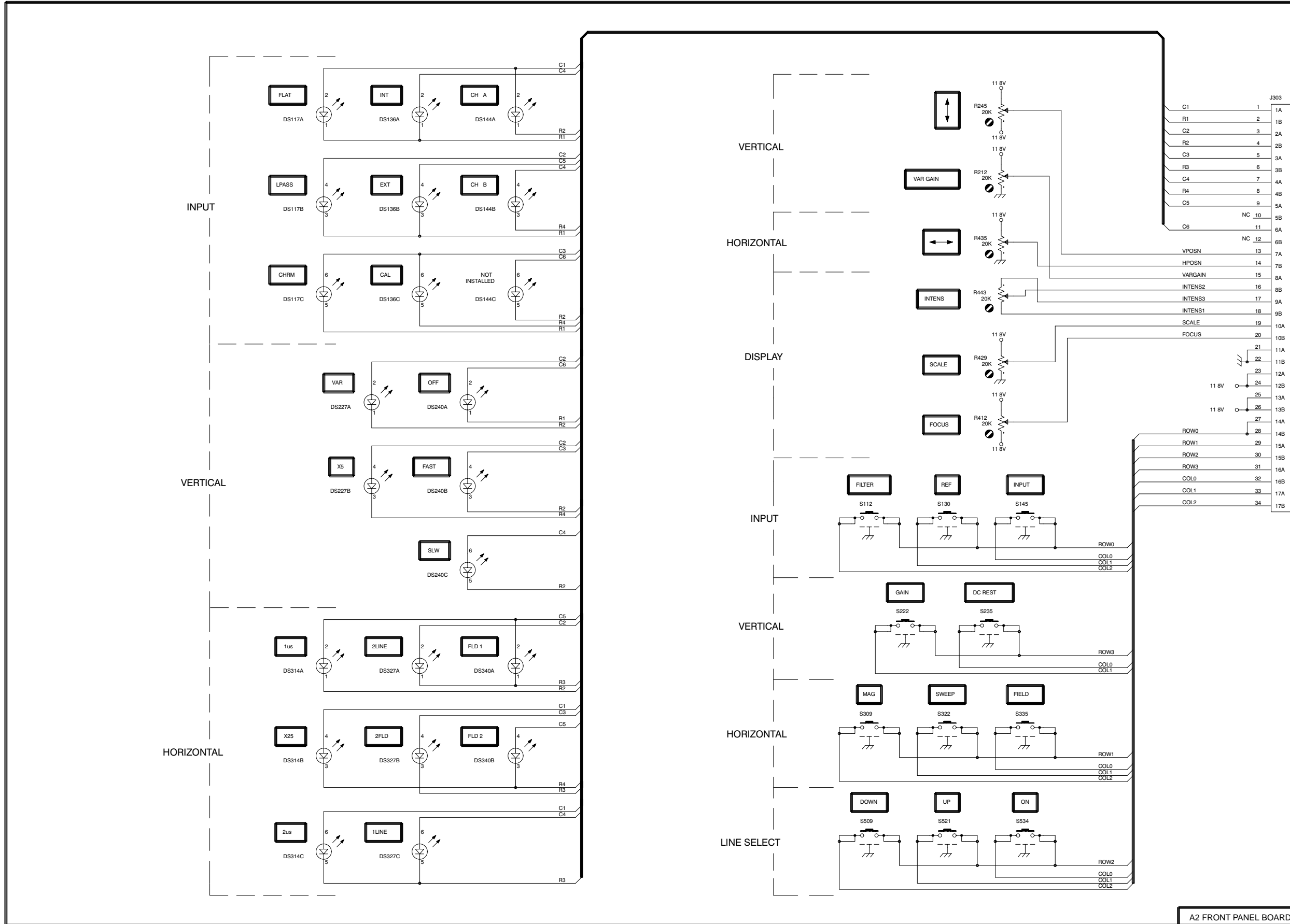

J303
CONNECTS
TO J107
A3
<5>
A3
MAIN
BOARD

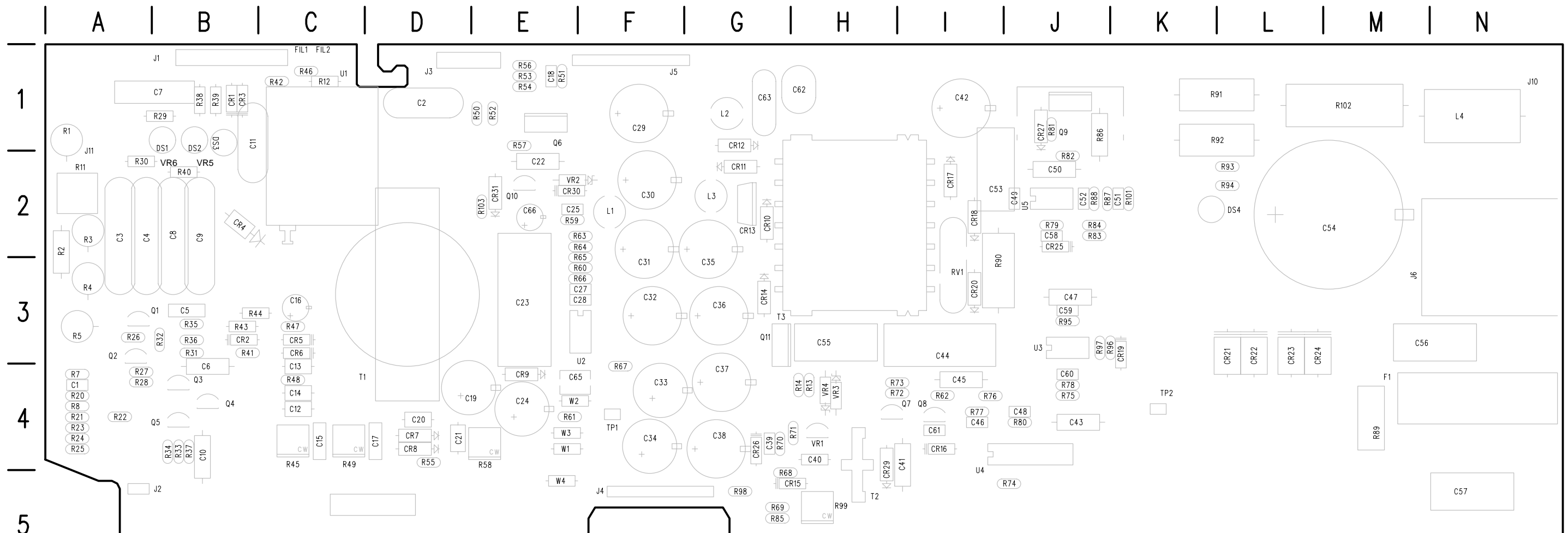

 **Static Sensitive Devices**
See Maintenance Section

A1 Power Supply Board

**Schematic Diagram <8>
Component Locator Chart**

The schematic diagram has an alpha-numeric grid to assist in locating parts within that diagram.

Assembly A1. Partial Assembly A1 also shown on Diagram 9.

Comp No	Diag Loc	Bd Loc	Comp No	Diag Loc	Bd Loc	Comp No	Diag Loc	Bd Loc	Comp No	Diag Loc	Bd Loc	Comp No	Diag Loc	Bd Loc
C29	F2	F1	C55	E3	H3	CR26	F4	H4	R71	F4	H4	R95	B4	J3
C30	F2	F2	C56	B2	M3	CR27	D3	J1	R96	A4	K3	R97	A3	J3
C31	F3	F3				CR28	G4	H5	R72	D5	H4	R98	F4	H4
			C57	B2	N5	CR29	E4	H5	R73	E5	I4	R101	C3	K2
C32	F2	F3	C58	B3	J2				R74	C4	J5	R102	C2	M1
C33	G2	F4	C59	B4	J3	DS4	D2	L2	R75	B5	J4			
C35	F3	G3	C60	B5	J4				R76	C5	I4			
C36	G2	G3	C62	E1	H1	F1	B2	M4						
			C63	E1	G1				R77	D4	I4	RV1	D2	I3
			C64	G4	G4				R78	B4	J4			
C37	G3	G4				J2	H5	B5	R79	B3	J2	T2	E4	H5
C38	G2	G4				J4	H3	F5	R80	C4	J4	T3	E2	G3
C39	E4	G4	CR10	F1	G2	J5	H1	F1	R81	D3	J1	TP1	F5	F4
C40	F4	H4	CR11	F2	G2	J6	A2	M3				TP2	E5	K4
C41	E4	I4	CR12	F2	G1	J10	A2	N1	R82	C3	J2			
			CR13	F3	G2				R83	C5	J2			
C42	D3	I1	CR14	E2	G3	L1	F3	F2	R84	B5	J2	U3A	C4	J3
C43	C4	J4	CR15	E4	G5	L2	F2	G1	R85	G4	H5	U3B	B3	J3
C44	D2	I3				L3	F2	G2	R86	D3	J1	U4A	D4	I5
C45	D4	I4	CR16	D5	I4	L4	C2	N1				U4B	C4	I5
C46	C5	I4	CR17	E2	I2							U5	C3	J2
			CR18	D2	I2				R87	D3	K2			
C47	A3	J3	CR19	B3	K3	Q7	D5	I4	R88	B4	J2	W1	G3	E4
C48	C4	J4	CR20	E3	I3	Q8	E4	I4	R89	B2	M4	W2	G3	E4
C49	D3	J2				Q9	D3	J1	R90	E3	I3	W3	G2	E4
C50	C3	J2	CR21	B2	L4				R91	D2	K1	W4	G2	E5
C51	C3	K2	CR22	B2	L4	R679	F2	F4	R92	D2	K1			
			CR23	B2	L4	R68	F4	G5	R93	D2	L2			
C52	C4	J2	CR24	B2	L4	R69	G4	G5	R94	D2	L2			
C53	E3	I2	CR25	B3	J2	R70	G4	G4						
C54	C2	M2												

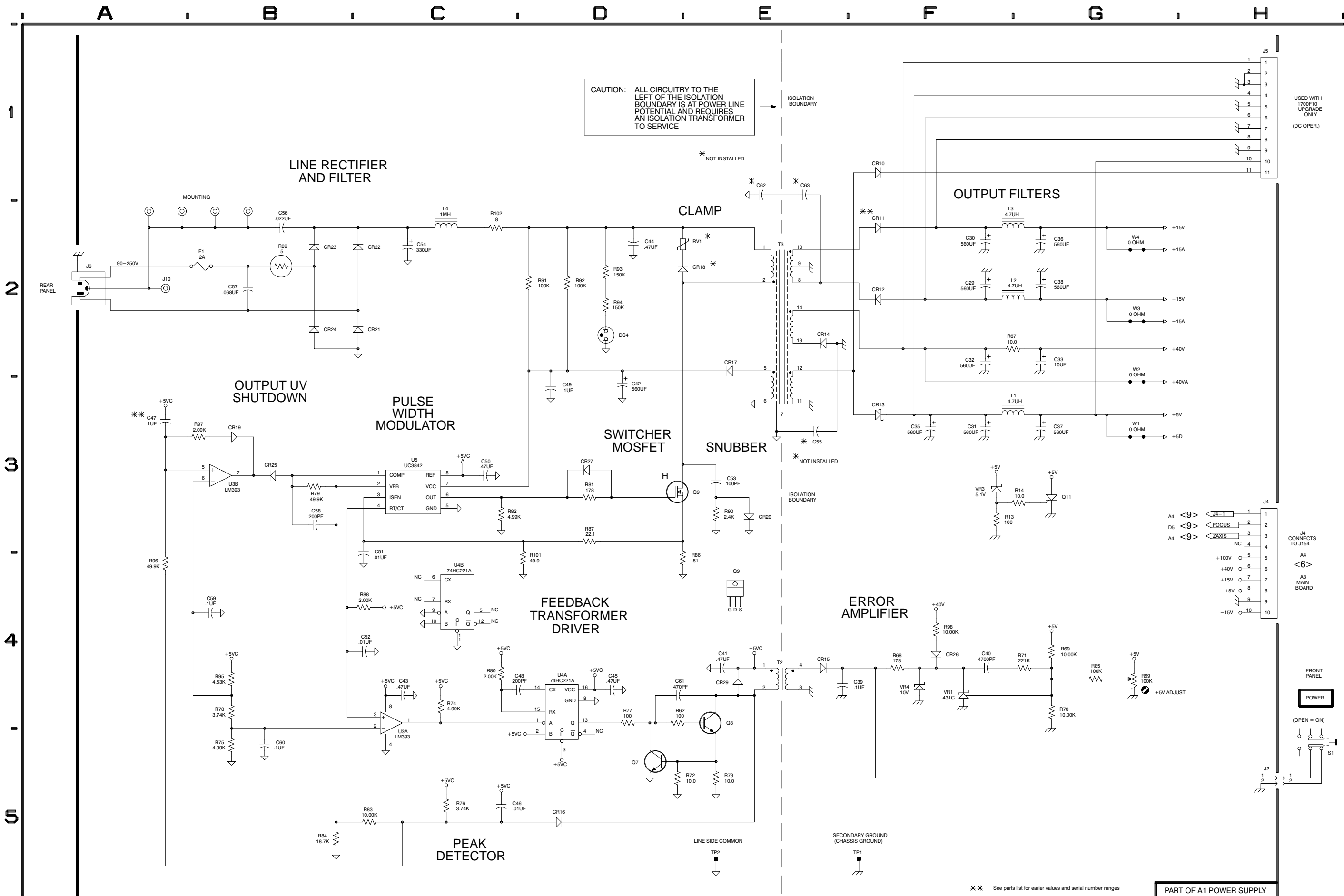

CAUTION: ALL CIRCUITRY TO THE LEFT OF THE ISOLATION BOUNDARY IS AT POWER LINE POTENTIAL AND REQUIRES AN ISOLATION TRANSFORMER TO SERVICE

* NOT INSTALLED

** See parts list for earlier values and serial number ranges

PART OF A1 POWER SUPPLY

A1 Power Supply Board Component Locator
(with cross-references to schematic diagrams 8 and 9)

Comp No	Diag No	Diag Loc	Bd Loc	Comp No	Diag No	Diag Loc	Bd Loc	Comp No	Diag No	Diag Loc	Bd Loc
C1	9	C4	A4	CR1	9	E2	B1	R2	9	E4	A2
C2	9	D3	D1	CR2	9	D4	B3	R3	9	E4	A2
C3	9	D3	A2	CR3	9	E2	B1	R4	9	E4	A3
C4	9	D3	B2	CR4	9	C2	B2	R5	9	E5	A3
C5	9	D4	B3	CR5	9	D2	C3	R7	9	B4	A4
C6	9	C4	B4	CR6	9	E2	C3	R8	9	B4	A4
C7	9	F3	B1	CR7	9	C2	D4	R11	9	F4	A2
C8	9	D3	B2	CR8	9	C2	D4	R12	9	D3	C1
C9	9	E2	B2	CR9	9	C1	E4	R20	9	C4	A4
C10	9	C5	B4	CR10	8	F1	G2	R21	9	C5	A4
C11	9	E2	B1	CR11	8	F2	G2	R22	9	D5	A4
C12	9	D2	C4	CR12	8	F2	G1	R23	9	B4	A4
C13	9	D2	C4	CR13	8	F3	G2	R24	9	D5	A4
C14	9	D2	C4	CR14	8	E2	G3	R25	9	B4	A4
C15	9	F2	C4	CR15	8	E4	G5	R26	9	E5	A3
C16	9	C2	C3	CR16	8	D5	I4	R27	9	E5	A4
C17	9	F2	D4	CR17	8	E2	I2	R28	9	E5	A4
C18	9	F3	E1	CR18	8	D2	I2	R29	9	D2	B1
C19	9	C1	D4	CR19	8	B3	K3	R30	9	D2	A2
C20	9	C2	D4	CR20	8	E3	I3	R31	9	D4	B3
C21	9	C1	D4	CR21	8	B2	L4	R32	9	E5	B3
C22	9	B2	E2	CR22	8	B2	L4	R33	9	C4	B4
C23	9	B2	E3	CR23	8	B2	L4	R34	9	C4	B4
C24	9	D1	E4	CR24	8	B2	L4	R35	9	D4	B3
C25	9	A3	E2	CR25	8	B3	J2	R36	9	D4	B3
C27	9	B1	E3	CR26	8	F4	H4	R37	9	C5	B4
C28	9	B1	E3	CR27	8	D3	J1	R38	9	E2	B1
C29	8	F2	F1	CR28	8	G4	H5	R39	9	E2	B1
C30	8	F2	F2	CR29	8	E4	H5	R40	9	D2	B2
C31	8	F3	F3	CR30	9	A2	E2	R41	9	D4	B3
C32	8	F2	F3	CR31	9	A2	E2	R42	9	E3	C1
C33	8	G2	F4	DS1	9	E2	B2	R43	9	E2	B3
C34	9	D1	F4	DS2	9	E2	B2	R44	9	D2	B3
C35	8	F3	G3	DS3	9	E3	B2	R45	9	F2	C4
C36	8	G2	G3	DS4	8	D2	L2	R46	9	E3	C1
C37	8	G3	G4	F1	8	B2	M4	R47	9	D2	C3
C38	8	G2	G4	FIL1	9	C3	C1	R48	9	C2	C4
C39	8	E4	G4	FIL2	9	C3	C1	R49	9	F2	C4
C40	8	F4	H4	R51	9	F3	E1	R50	9	F2	E1
C41	8	E4	I4	R52	9	F2	E1	R51	9	F3	E1
C42	8	D3	I1	J1	9	F3	B1	R52	9	F2	E1
C43	8	C4	J4	J2	8	H5	B5	R53	9	F2	E1
C44	8	D2	I3	J3	9	F2	D1	R54	9	F2	E1
C45	8	D4	I4	J4	8	H3	F5	R55	9	D2	D4
C46	8	C5	I4	J5	8	H1	F1	R56	9	F3	E1
C47	8	A3	J3	J6	8	A2	M3	R57	9	B2	E1
C48	8	C4	J4	J10	8	A2	N1	R58	9	D2	E4
C49	8	D3	J2	J11	9	F4	A2	R59	9	B1	E2
C50	8	C3	J2	L1	8	F3	F2	R60	9	C1	E3
C51	8	C3	K2	L2	8	F2	G1	R61	9	D1	E4
C52	8	C4	J2	L3	8	F2	G2	R63	9	A2	E2
C53	8	E3	I2	L4	8	C2	N1	R64	9	C2	E2
C54	8	C2	M2	Q1	9	E5	B3	R65	9	B1	E3
C55	8	E3	H3	Q2	9	E5	A3	R66	9	B1	E3
C56	8	B2	M3	Q3	9	D4	B4	R67	8	F2	F4
C57	8	B2	N5	Q4	9	D4	B4	R68	8	F4	G5
C58	8	B3	J2	Q5	9	C4	B4	R69	8	G4	G5
C59	8	B4	J3	Q6	9	B2	E1	R70	8	G4	G4
C60	8	B5	J4	Q7	8	D5	I4	R71	8	F4	H4
C62	8	E1	H1	Q8	8	E4	I4	R72	8	D5	H4
C63	8	E1	G1	Q9	8	D3	J1	R73	8	E5	I4
C64	8	G4	G4	Q10	9	A2	E2	R74	8	C4	J5
C65	9	B2	F4	R1	9	E3	A1				
C66	9	A2	E2								

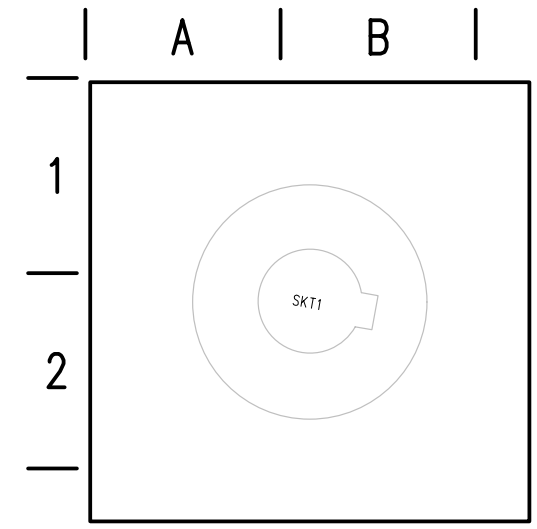

A10 CRT Socket Board (Front of Board)

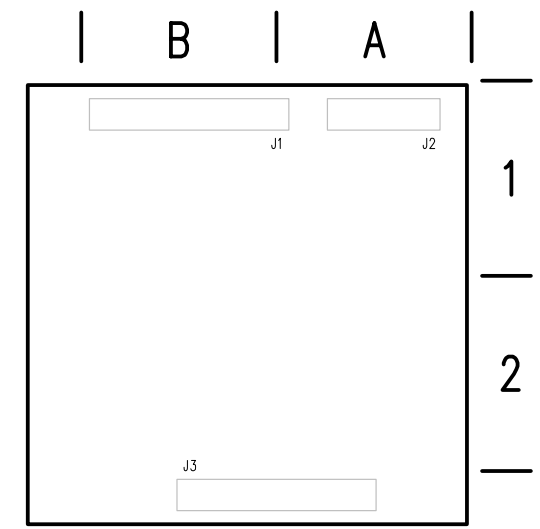

A10 CRT Socket Board (Back of Board)

Comp No	Diag No	Diag Loc	Bd Loc	Comp No	Diag No	Diag Loc	Bd Loc	Comp No	Diag No	Diag Loc	Bd Loc
R75	8	B5	J4	R92	8	D2	K1	U1	9	D1	C1
R76	8	C5	I4	R93	8	D2	L2	U2	9	B1	F4
R77	8	D4	I4	R94	8	D2	L2	U3A	8	C4	J3
R78	8	B4	J4	R95	8	B4	J3	U3B	8	B3	J3
R79	8	B3	J2	R96	8	A4	K3	U4A	8	D4	I5
R80	8	C4	J4	R97	8	A3	J3	U4B	8	C4	I5
R81	8	D3	J1	R98	8	F4	H4	U5	8	C3	J2
R82	8	C3	J2	R101	8	C3	K2	VR1	8	F4	H4
R83	8	C5	J2	R102	8	C2	M1	VR2	9	A2	E2
R84	8	B5	J2	R103	9	A2	E2	VR5	9	D2	B2
R85	8	G4	H5	RV1	8	D2	I3	VR6	9	D2	B2
R86	8	D3	J1	T1	9	B2	C4	W1	8	G3	E4
R87	8	D3	K2	T2	8	E4	H5	W2	8	G3	E4
R88	8	B4	J2	T3	8	E2	G3	W3	8	G2	E4
R89	8	B2	M4	TP1	8	F5	F4	W4	8	G2	E5
R90	8	E3	I3	TP2	8	E5	K4				
R91	8	D2	K1								

A B C D E F G H

1
2
3
4
5

HV OSC & ERROR AMP

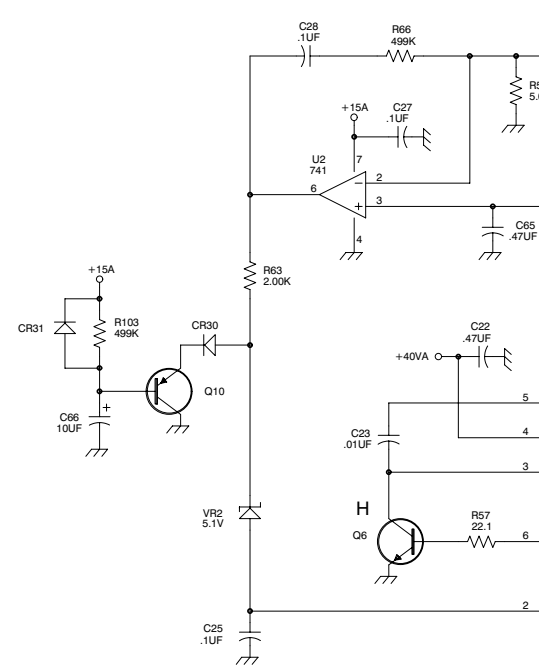

GRID DRIVE

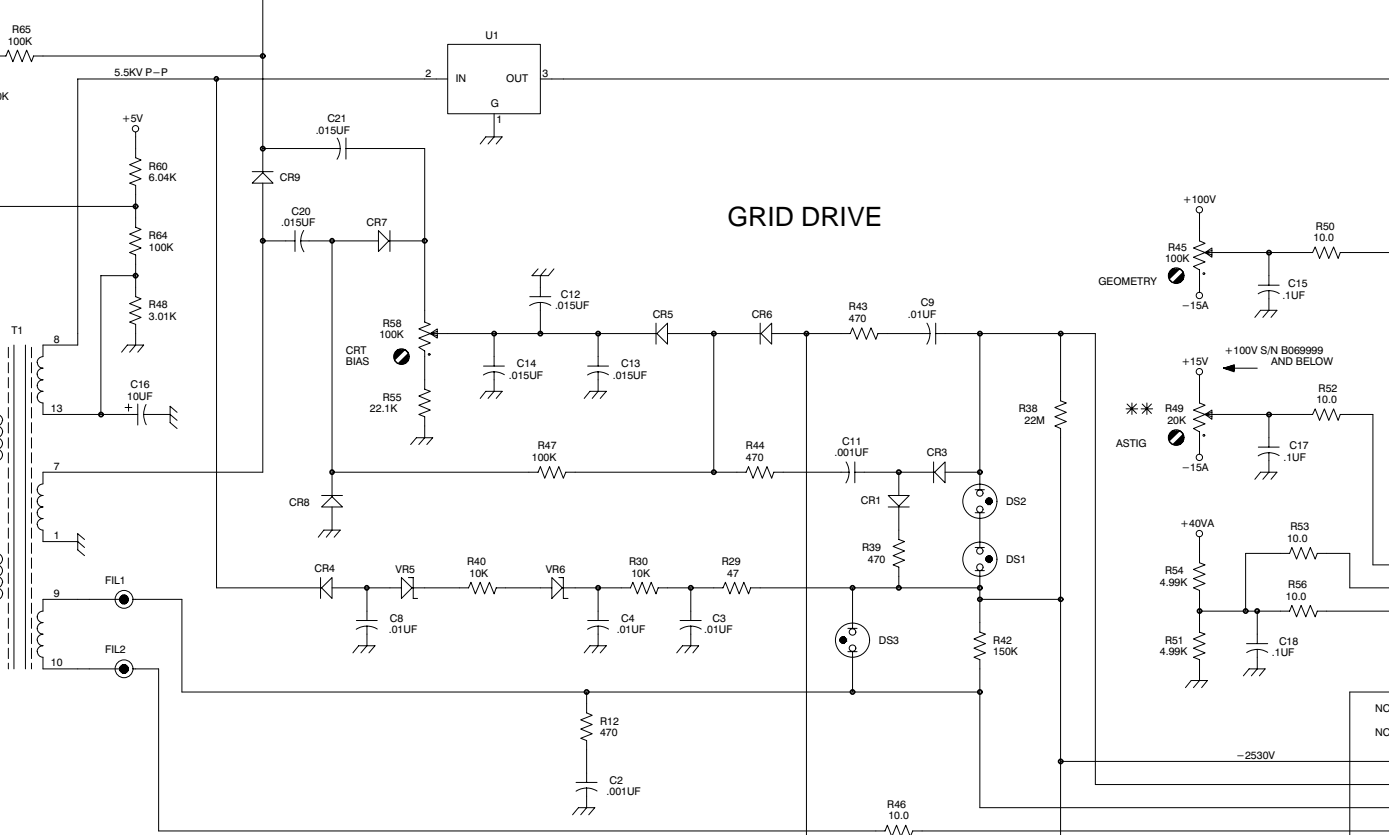

Z AXIS AMPLIFIER

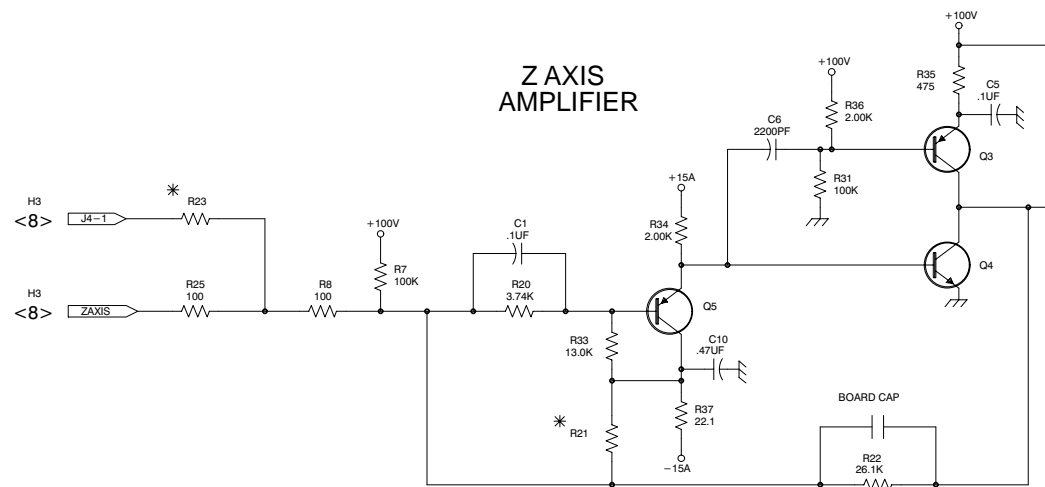

FOCUS AMPLIFIER

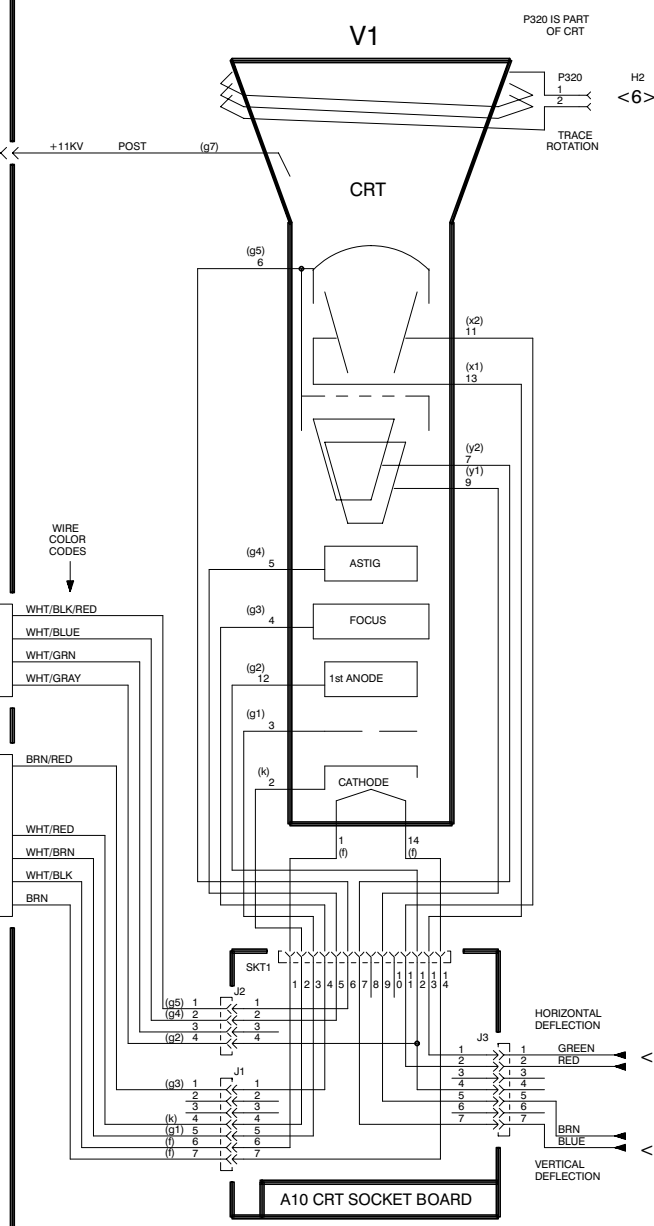
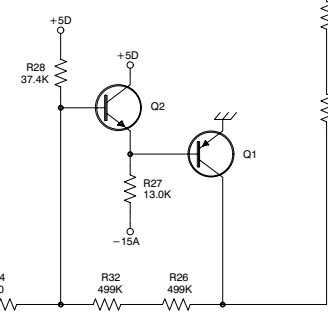

V1 TUBE SOCKET VISUAL AID

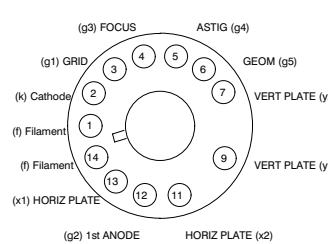

** See parts list for earlier values and serial number ranges

PART OF A1 POWER SUPPLY



Replaceable Mechanical Parts

Section 10

Replaceable Mechanical Parts

This section contains a list of the components that are replaceable for the 1730-Series. Use this list to identify and order replacement parts. There is a separate Replaceable Mechanical Parts list for each instrument.

Parts Ordering Information

Replacement parts are available from or through your local Tektronix, Inc., Field Office or representative.

Changes to Tektronix instruments are sometimes made to accommodate improved components as they become available and to give you the benefit of the latest circuit improvements. Therefore, when ordering parts, it is important to include the following information in your order.

- Part number
- Instrument type or model number
- Instrument serial number
- Instrument modification number, if applicable

If a part you have ordered has been replaced with a new or improved part, your local Tektronix, Inc., Field Office or representative will contact you concerning any change in part number.

Change information, if any, is located at the rear of this manual.

Using the Replaceable Mechanical Parts List

The tabular information in the Replaceable Mechanical Parts list is arranged for quick retrieval. Understanding the structure and features of the list will help you find all of the information you need for ordering replaceable parts.

Cross Index–Mfr. Code Number to Manufacturer

The Mfg. Code Number to Manufacturer Cross Index for the mechanical parts list is located immediately after this page. The cross index provides codes, names, and addresses of manufacturers of components listed in the mechanical parts list.

Abbreviations

Abbreviations conform to American National Standards Institute (ANSI) standard Y1.1.

Chassis Parts

Chassis-mounted parts and cable assemblies are located at the end of the Replaceable Electrical Parts list.

Column Descriptions

Figure & Index No. (Column 1)	Items in this section are referenced by figure and index numbers to the illustrations.																																																												
Tektronix Part No. (Column 2)	Indicates part number to be used when ordering replacement part from Tektronix.																																																												
Serial No. (Column 3 and 4)	Column three (3) indicates the serial number at which the part was first used. Column four (4) indicates the serial number at which the part was removed. No serial number entered indicates part is good for all serial numbers.																																																												
Qty (Column 5)	This indicates the quantity of mechanical parts used.																																																												
Name and Description (Column 6)	<p>An item name is separated from the description by a colon (:). Because of space limitations, an item name may sometimes appear as incomplete. Use the U.S. Federal Catalog handbook H6-1 for further item name identification.</p> <p>Following is an example of the indentation system used to indicate relationship.</p> <table><thead><tr><th>1</th><th>2</th><th>3</th><th>4</th><th>5</th><th>Name & Description</th></tr></thead><tbody><tr><td></td><td></td><td></td><td></td><td></td><td>Assembly and/or Component</td></tr><tr><td></td><td></td><td></td><td></td><td></td><td>Mounting parts for Assembly and/or Component</td></tr><tr><td></td><td></td><td></td><td></td><td></td><td>*MOUNTING PARTS*/*END MOUNTING PARTS*</td></tr><tr><td></td><td></td><td></td><td></td><td></td><td>Detail Part of Assembly and/or Component</td></tr><tr><td></td><td></td><td></td><td></td><td></td><td>Mounting parts for Detail Part</td></tr><tr><td></td><td></td><td></td><td></td><td></td><td>*MOUNTING PARTS*/*END MOUNTING PARTS*</td></tr><tr><td></td><td></td><td></td><td></td><td></td><td>Parts of Detail Part</td></tr><tr><td></td><td></td><td></td><td></td><td></td><td>Mounting parts for Parts of Detail Part</td></tr><tr><td></td><td></td><td></td><td></td><td></td><td>*MOUNTING PARTS*/*END MOUNTING PARTS*</td></tr></tbody></table> <p>Mounting Parts always appear in the same indentation as the Item it mounts, while the detail parts are indented to the right. Indented items are part of and included with, the next higher indentation. Mounting parts must be purchased separately, unless otherwise specified.</p>	1	2	3	4	5	Name & Description						Assembly and/or Component						Mounting parts for Assembly and/or Component						*MOUNTING PARTS*/*END MOUNTING PARTS*						Detail Part of Assembly and/or Component						Mounting parts for Detail Part						*MOUNTING PARTS*/*END MOUNTING PARTS*						Parts of Detail Part						Mounting parts for Parts of Detail Part						*MOUNTING PARTS*/*END MOUNTING PARTS*
1	2	3	4	5	Name & Description																																																								
					Assembly and/or Component																																																								
					Mounting parts for Assembly and/or Component																																																								
					MOUNTING PARTS/*END MOUNTING PARTS*																																																								
					Detail Part of Assembly and/or Component																																																								
					Mounting parts for Detail Part																																																								
					MOUNTING PARTS/*END MOUNTING PARTS*																																																								
					Parts of Detail Part																																																								
					Mounting parts for Parts of Detail Part																																																								
					MOUNTING PARTS/*END MOUNTING PARTS*																																																								
Mfr. Code (Column 7)	Indicates the code number of the actual manufacturer of the part. (Code to name and address cross reference can be found immediately after this page.)																																																												
Mfr. Part Number (Column 8)	Indicates actual manufacturer's part number.																																																												

Cross Index – Mfr. Code Number To Manufacturer

Mfr. Code	Manufacturer	Address	City, State, Zip Code
0KB01	STAUFFER SUPPLY CO	810 SE SHERMAN	PORTLAND, OR 97214-4657
0KBZ5	Q & D PLASTICS INC	1812 – 16TH AVENUE PO BOX 487	FOREST GROVE, OR 97116-0487
22670	GM NAMEPLATE INCORPORATED	2040 15TH AVE WEST	SEATTLE, WA 981192783
2K262	BOYD CORPORATION	6136 NE 87TH AVENUE	PORTLAND, OR 97220
34785	DEK INC.	3480 SWENSEN AVE.	ST. CHARLES, IL 60174-3450
3L462	QUALITY PLASTICS	DIV OF MOLL PLASTICRAFTERS 2101 CRESTVIEW DR.	NEWBERG, OR 97132
55335	JKL COMPONENTS	13343 PAXTON ST	PACOIMA, CA 91331
56501	THOMAS & BETTS CORPORATION	1555 LINFIELD RD	MEMPHIS, TN 38119
5F520	PANEL COMPONENTS CORP	PO BOX 115	OSKALOOSA, IA 52577-0115
71400	BUSSMANN	DIVISION COOPER INDUSTRIES INC PO BOX 14460	ST LOUIS, MO 63178
73743	FISCHER SPECIAL MFG CO	111 INDUSTRIAL RD PO BOX 76500	COLD SPRINGS, KY 41076
80009	TEKTRONIX INC	14150 SW KARL BRAUN DR PO BOX 500	BEAVERTON, OR 97077-0001
80126	PACIFIC ELECTRICORD CO	747 WEST REDONDO BEACH PO BOX 10	GARDENA, CA 90247-4203
85471	BOYD CORPORATION	13885 RAMONA AVE	CHINO, CA 91710
93907	CAMCAR DIV OF TEXTRON INC	ATTN: ALICIA SANFORD 516 18TH AVE	ROCKFORD, IL 611045181
TK2364	CAPSTONE ELECTRONICS	9500 SW NIMBUS AVE BUILDING E	BEAVERTON, OR 97008-7163
TK2541	AMERICOR ELECTRONICS LTD	UNIT-H 2682 W COYLE AVE	ELK GROVE VILLAGE, IL 60007

1730-Series Replaceable Mechanical Parts

Replaceable Mechanical Parts

Fig. & Index No.	Tektronix Part No.	Serial Number Effective	Dscont	Qty	Name & Description	Mfr. Code	Mfr. Part No.
1-1	426-2102-00			1	FRAME,CRT:BEZEL *MOUNTING PARTS*	3L462	ORDER BY DESCR
-2	211-0690-02			2	SCR,MACH:6-32 X 0.875,PNH,SST BLKOXD,TORX & SLOT *END MOUNTING PARTS*	93907	B20-70430
-3	333-3304-00			1	PANEL,FRONT:LITTLE (1730/1731 ONLY)	22670	ORDER BY DESCR
	333-3483-00			1	PANEL,FRONT:1735 (1735 ONLY)	22670	ORDER BY DESCR
-4	378-0258-00			1	FLTR,CONTRASTIN:GRAY,POLYCARBONATE	80009	378-0258-00
-5	333-3300-01			1	PANEL,FRONT:1730 MAIN (1730 ONLY)	80009	333-3300-01
	333-3301-01			1	PANEL,FRONT:1731 MAIN (1731/1731 PM ONLY)	80009	333-3301-01
	333-3439-00			1	PANEL,FRONT:1735 (1735 ONLY) *MOUNTING PARTS*	22670	ORDER BY DESCR
-6	211-0721-00			1	SCREW,MACHINE:6-32 X 0.375,PNH,STL,CDPL,T-15 TORX	0KB01	ORDER BY DESCR
-6	211-0720-01			1	SCREW,MACHINE:6-32 X 0.5,PNH,STL,CDPL,T-15 SLOT *END MOUNTING PARTS*	0KB01	ORDER BY DESCR
-7	-----			1	CIRCUIT BD ASSY:FRONT PNL (SEE A2 REPL) *MOUNTING PARTS*		
-8	211-0721-00			4	SCREW,MACHINE:6-32 X 0.375,PNH,STL,CDPL,T-15 TORX *END MOUNTING PARTS*	0KB01	ORDER BY DESCR
-9	426-2101-01		B069999	1	FRAME SECT,CAB:FRONT	3L462	ORDER BY DESCR
-9	426-2101-04	B070000		1	FRAME SECT,CAB:FRONT *MOUNTING PARTS*	3L462	ORDER BY DESCR
-10	211-0721-00			4	SCREW,MACHINE:6-32 X 0.375,PNH,STL,CDPL,T-15 TORX *END MOUNTING PARTS*	0KB01	ORDER BY DESCR
-11	-----			1	SWITCH,PUSH:0.4A,125VAC,W/SLDR LUG,BUTTON W/YELLOW INDICATOR (SEE S1 REPL) *MOUNTING PARTS*		
-12	210-0405-00			2	NUT,PLAIN,HEX:2-56 X 0.188,BRS CD PL	73743	12157-50
-13	211-0100-00			2	SCREW,MACHINE:2-56 X 0.750,PNH,STL CD PL,POZ *END MOUNTING PARTS*	0KB01	ORDER BY DESCR
-14	-----			1	CIRCUIT BD ASSY:MAIN (SEE A3 REPL) *MOUNTING PARTS*		
-15	211-0721-00			8	SCREW,MACHINE:6-32 X 0.375,PNH,STL,CDPL,T-15 TORX *END MOUNTING PARTS*	0KB01	ORDER BY DESCR
-16	-----			1	CIRCUIT BD ASSY:GRATICULE LIGHT (SEE A3A1 REPL)		
-17	337-3321-00			1	SHIELD,ELEC:CKT BD	85471	337-3321-00
-18	-----			1	CIRCUIT BD ASSY:POWER (SEE A1 REPL) *MOUNTING PARTS*		
-19	211-0721-00		B078566	7	SCREW,MACHINE:6-32 X 0.375,PNH,STL,CDPL,T-15 TORX	0KB01	ORDER BY DESCR
-19	211-0721-00	B078567		6	SCREW,MACHINE:6-32 X 0.375,PNH,STL,CDPL,T-15 TORX	0KB01	ORDER BY DESCR
-20	337-3796-01			1	SHIELD,ELEC:0.032 BRASS,C26000,0.5 HARD	80009	337379601
-21	211-0014-00			2	SCREW,MACHINE:4-40 X 0.5,PNH,STL CD PL,POZ *END MOUNTING PARTS*	93907	ORDER BY DESCR
-22	131-3573-00			1	CONN,PLUG,ELEC:MALE,W/LOCKING ADAPTER	80126	B-0779
-23	337-3257-00			2	SHIELD,CKT BD:LV PWR SUPPLY	2K262	ORDER BY DESCR
-24	337-3931-00			1	SHIELD,ELEC:ALUMINUM	80009	337393100

1730-Series Replaceable Mechanical Parts

Fig. & Index No.	Tektronix Part No.	Serial Number Effective	Dscont	Qty	Name & Description	Mfr. Code	Mfr. Part No.
-25	175-9872-01			1	CA ASSY,SP,ELEC:2,18 AWG,2.5 L,0-N	TK2364	175-9872-01
-26	333-3305-03		B069999	1	PANEL,REAR:1730/1731/1735	80009	333-3305-03
-26	333-3305-04	B070000	B078095	1	PANEL,REAR:1730/1731/1735	80009	333-3305-04
-26	333-3305-05	B078096		1	PANEL,REAR:1730/1731/1735 *MOUNTING PARTS*	80009	333-3305-04
-27	211-0721-00			3	SCREW,MACHINE:6-32 X 0.375,PNH,STL,CDPL,T-15 TORX *END MOUNTING PARTS*	0KB01	ORDER BY DESCR
-28	174-0335-01			1	LEAD,ELECTRICAL:22 AWG,9.75 L,9-N	80009	174-0335-01
-29	174-0123-02			1	CABLE ASSY SP:ELEC,24,26 AWG,21.0 L, RIBBON *MOUNTING PARTS*	80009	174-0123-02
-30	214-3903-01			2	SCREW,JACK:4-40 X 0.312 EXT THD,4-40 INT THD,0.188 HEX,STEEL,CADPLATE *END MOUNTING PARTS*	0KB01	214-3903-01
-31	-----			1	CIRCUIT BD ASSY:SERIAL FILTER (SEE A11 REPL) *MOUNTING PARTS*		
-32	214-3903-01			2	SCREW,JACK:4-40 X 0.312 EXT THD,4-40 INT THD,0.188 HEX,STEEL,CADPLATE *END MOUNTING PARTS*	0KB01	214-3903-01
-33	348-1464-00			1	MANCHET:CRT,END RUBBER MANCHET,31.5MM THK X 63MM OD,50.5 ID	80009	348-1464-00
-34	407-4395-00			1	BRACKET,CRT:BACK,0.062,AL *MOUNTING PARTS*	80009	407-4395-00
-35	210-0457-00			2	NUT,PL,ASSEM WA:6-32 X 0.312,STL CD PL *END MOUNTING PARTS*	0KB01	ORDER BY DESCR
-36	-----			1	CIRCUIT BD ASSY:CRT SOCKET (SEE A10 REPL)		
-37	346-0133-00			1	STRAP,TIEDOWN,E:14.0 X 0.091,NYLON	56501	TY234M EURO DIRECT PURCH
-38	337-4064-00			1	SHIELD,ELEC:MU-METAL CRT SHIELD,SAF CONTROLLED	80009	337-4064-00
-39	334-1379-00			1	MARKER,IDENT:MKD HI VACUUM	22670	ORDER BY DESCR
-40	386-4443-00			1	SUPPORT,SHIELD:CRT,FRONT,PLASTIC	80009	386-4443-00
-41	-----			1	ELECTRON,TUBE:CRT,FINISHED (SEE V1 REPL)		
-42	348-0171-00			1	GROMMET,PLASTIC:BLACK,U-SHAPED,0.276 ID	0KBZ5	NA
-43	343-0916-00		B078566	1	CLAMP,LOOP:0.5 ID,NYLON	34785	029-500
-43	343-0013-00	B078567		1	CLAMP,LOOP:0.375 ID,PLASTIC	34785	029-500
-44	426-2103-07			1	FRAME,CHASSIS:CHASSIS FRAME,ALUM	80009	426-2103-07
-45	211-0720-01		B078566	2	SCREW,MACH:6-32 X 0.50,PNH,STL,TORX T-15 WITH SLOT	0KB01	211-0720-01
-45	211-0720-01	B078567		3	SCREW,MACH:6-32 X 0.50,PNH,STL,TORX T-15 WITH SLOT	0KB01	211-0720-01
-51	129-1308-00	B078567		1	SPACER,POST:6-32X0.75 HEX,STL,CAD PL	0570	4538-632-s-3
					STANDARD ACCESSORIES		
	070-7948-05			1	MANUAL,TECH:INSTR,1730 WAVEFORM MONITOR B060000 AND UP	80009	070794805
	150-0168-00			3	LAMP,INCAND:14V,0.08A,WEDGE BASE,T1.75 FOR SKT MT	55335	73W
	159-0021-00			1	FUSE,CARTRIDGE:3AG,2A,250V,FAST BLOW	71400	AGC-2
-46	161-0216-00			1	CABLE ASSY,PWR:3,18 AWG,2.5M L,BLACK (STANDARD ONLY)	80126	C7120-25M-BL
					OPTIONAL ACCESSORIES		
-47	161-0215-00			1	CABLE ASSY,PWR:3,0.75MU,2.5MM L,GREY (EUROPEAN OPTION A1 ONLY)	80126	0-5335-008-GY
-48	161-0066-10			1	CA ASSY,PWR:3,0.1MM SQ,250V/10A,2.5 METER,STR, IEC320,RCPT X 13A,FUSED UK PLUG(13A FUSE),UNIT (UNITED KINGDOM OPTION A2 ONLY)	TK2541	ORDER BY DESCR

1730-Series Replaceable Mechanical Parts

Fig. & Index No.	Tektronix Part No.	Serial Number Effective	Dscont	Qty	Name & Description	Mfr. Code	Mfr. Part No.
-49	161-0066-11			1	CA ASSY,PWR:3,1.0MM SQ,250V/10A,2.5 METER,STR, IEC320,RCPT,AUSTRALIA,SAFTEY CONTROLLED (AUSTRALIAN OPTION A3 ONLY)	80126	ORDER BY DESCR
-50	161-0212-00			1	CABLE ASSY,PWR:3,1.0MM SQ,220V,2.5 METERS SWISS (SWISS OPTION A5 ONLY)	5F520	86542000
	016-0475-00			1	VIEWING HOOD:	80009	016-0475-00
	200-3897-01			1	COVER,FRONT:1700F02,HOT STAMPED	80009	200-3897-01
	-----			1	PLAIN CASE ASSY:1700F00		
	-----			1	PTD CASE ASSY:1700F02		
	-----			1	RACK ADAPTER:1700F05		
	-----			1	FILLER PANEL:1700F06		
	-----			1	DRAWER,UTILITY:1700F07		

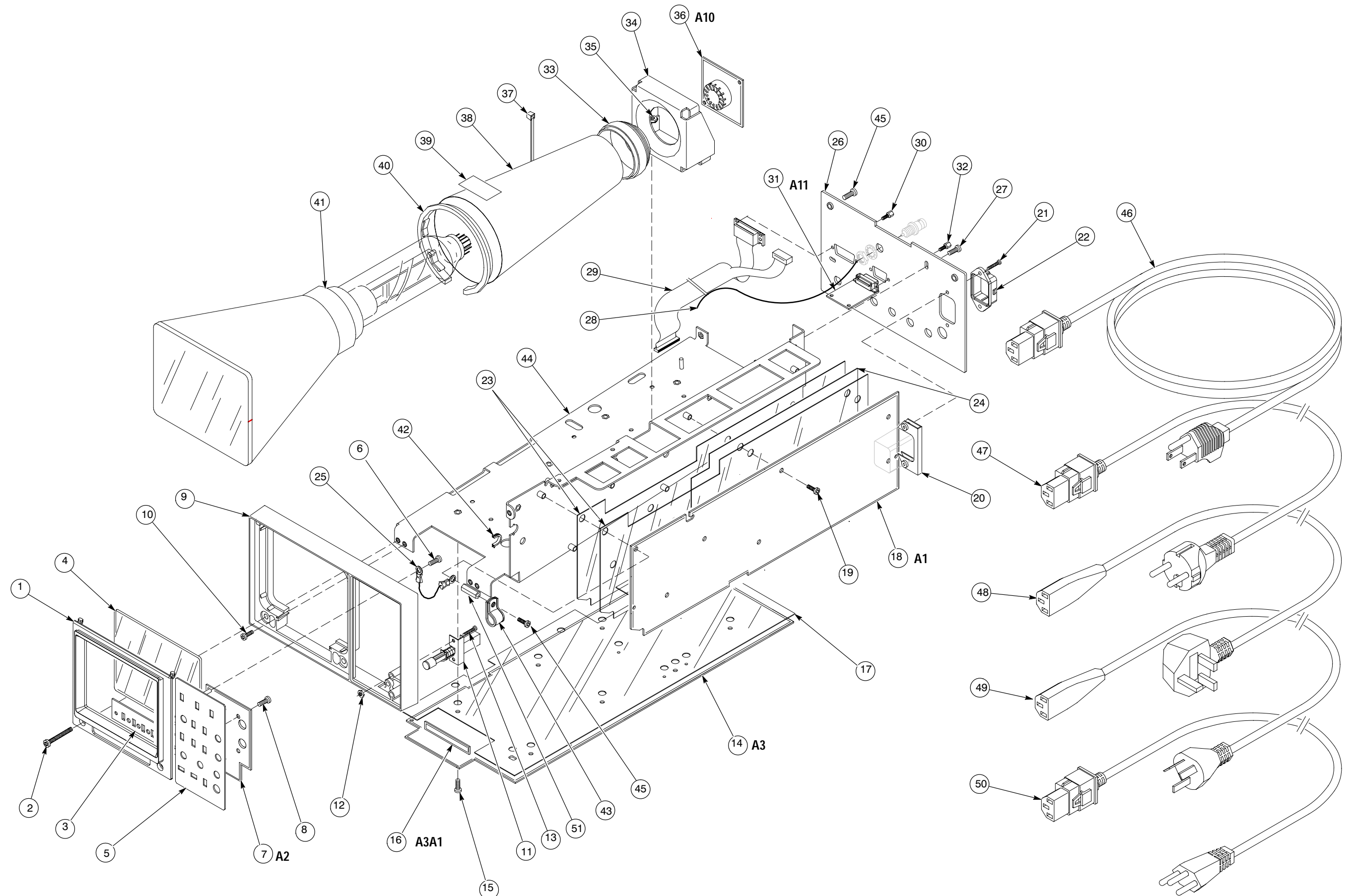

1730-Series Waveform Monitor

